

**REQUEST FOR BID**  
**(RFB)**

## **Barwa Adda Expressway Limited (BAEL)**

**Six-Laning of Barwa-Adda- Panagarh Section of NH-2 from km 398.240 to km 521.120 including Panagarh Bypass in the States of Jharkhand and West Bengal**

**Supply & Installation of Retro Reflective Signage & Gantry boards at various locations between km 398.240 to km 521.120 in the States of Jharkhand and West Bengal**

Document Downloading Date	From July 08, 2023 (11.00 Hrs.) to July 22, 2023 (11.00 Hrs.)
Last Date And Time for Receipt of Bids	June 22, 2023 at 18.00 Hrs. (Soft copy) July 24, 2023 at 18.00 Hrs. (Hard copy)
Place of Opening of Bids	Barwa Adda Expressway Limited The IL&FS Financial Center, Plot C-22, G Block, Bandra Kurla Complex, Mumbai- 400051 E-mail: <a href="mailto:itnl.projectbids@itnlindia.com">itnl.projectbids@itnlindia.com</a>
Officer Inviting Bids	Mr. Ravi Praveen Kumar/ Mr. Sachin Joshi Barwa Adda Expressway Limited The IL&FS Financial Center, Plot C-22, G Block, Bandra Kurla Complex, Mumbai- 400051 Tel: +91 022-26593693/022-26594804 E-mail: <a href="mailto:itnl.projectbids@itnlindia.com">itnl.projectbids@itnlindia.com</a> Website: <a href="http://www.itnlindia.com">www.itnlindia.com</a>

**Barwa Adda Expressway Limited  
(BAEL)**

**BID DOCUMENT**

**For**

**Six-Laning of Barwa-Adda- Panagarh Section of NH-2 from km 398.240 to km 521.120  
including Panagarh Bypass in the States of Jharkhand and West Bengal**

**Supply & Installation of Retro Reflective Signage & Gantry boards at various locations  
between km 398.240 to km 521.120 in the States of Jharkhand and West Bengal**

**Contents**

**Volume 1**

**INVITATION FOR BID**

- Section 1 : Instructions to Bidders
- Section 2 : Qualification Information and other forms
- Section 3 : Part I - General Conditions of Contract  
Part II - Special Conditions of Contract
- Section 4 : Contract Data
- Section 5 : Technical Specifications & Design

**Volume 2**

- Section 6 : Bill of Quantities for Sign Boards Works
- Section 7 : Forms of Bid and Securities, Acceptance, Agreement

# VOLUME 1

## CONTENTS

### INVITATION FOR BID

<b>Section</b>	<b>Description</b>	<b>Page No</b>
1	Instructions to Bidders	7
2	Qualification Information and other Forms	33
3	Part I: General Conditions of Contract	41
	Part II: Special Conditions of Contract	65
4	Contract Data	71
5	Technical Specifications & Design	76

## **Barwa Adda Expressway Limited (BAEL)**

The IL&FS Financial Center, Plot C-22, G Block, Bandra Kurla Complex, Mumbai- 400051

Tel.: +91 022-26593609,

E-mail: [itnl.projectbids@itnlindia.com](mailto:itnl.projectbids@itnlindia.com), Website: [www.itnlindia.com](http://www.itnlindia.com)

CIN: U45400MH2013PLC242336

---

### **INVITATION FOR BID**

**Date: July 08, 2023**

**Sub.: Six-Laning of Barwa-Adda- Panagarh Section of NH-2 from km 398.240 to km 521.120 including Panagarh Bypass in the States of Jharkhand and West Bengal-**

**Supply & Installation of Retro Reflective Signage & Gantry boards at various locations between km 398.240 to km 521.120 in the States of Jharkhand and West Bengal.**

Dear Sir,

- (1) M/s Barwa Adda Expressway Limited (“BAEL”) hereby invites sealed Bid from contractors for the work of “Six-Laning of Barwa-Adda- Panagarh Section of NH-2 from km 398.240 to km 521.120 including Panagarh Bypass in the States of Jharkhand and West Bengal – “**Supply & Installation of Retro Reflective Signage & Gantry boards at various locations between km 398.240 to km 521.120 in the States of Jharkhand and West Bengal.**
- (2) The period for completion of Supply & Installation works for Retro Reflective Signage & Gantry boards shall be **6 months** period and while you will be required to maintain road for a **Defect Liability Period of 18 Months and OEM Warranty for reflectivity shall be minimum 10 years.**
- (3) Deleted
- (4) Bidding documents may be downloaded by the contractors, free of cost, from the Employer’s web site [www.itnlindia.com](http://www.itnlindia.com) from ***July 08, 2023, 11.00 Hrs to July 22, 2023, 11.00 Hrs.***
- (5) Bid must be accompanied by **Bid Security as per details provided in following table** for BOQ given in Annexure 1 of Section 6, in favor of Barwa Adda Expressway Limited, payable at Mumbai.

<b>Sr. No.</b>	<b>Particular</b>	<b>Bid Security in ₹</b>
1	Supply & Installation of Retro-reflective & Gantry Boards	1,50,000/- (Rupees one lac fifty thousand only)

Bid Security will have to be in the form as specified in the Bidding Document and shall have to be valid for **60 days beyond the validity of the Bid.**

- (6) The technical and financial bids shall be submitted separately through email id **itnl.projectbids@itnlindia.com**; financial bids shall be submitted with password protection, the password shall be sent to the dedicated email id **itnltolls.password@itnlindia.com** on or before **1800 Hrs IST on July 22, 2023** and
- (7) Hard copy delivered to office of Barwa Adda Expressway Limited, Add: The IL&FS Financial Center, Plot C-22, G Block, Bandra Kurla Complex, Mumbai- 400051 **on or before 1800 Hrs IST, July 24, 2023** by hand or by post/Courier.

**Signature of Authorized Officer**

**Barwa Adda Expressway Limited**

**SECTION 1:**  
**INSTRUCTIONS TO BIDDERS**  
**(ITB)**

# **SECTION 1: INSTRUCTIONS TO BIDDERS**

## **CONTENTS**



	<b>Page No.</b>		<b>Page No.</b>
<b>A General</b>		<b>D Submission of Bids</b>	
1 Scope of Works	8	19 Sealing and Marking of Bids	20
2 Source of Funds	9	20 Deadline for Submission of Bids	20
3 Eligible Bidders	9	21 Late Submission of Bids	21
4 Qualification of the Bidder	10	22 Modification and Withdrawal of Bids	21
5 One Bid per Bidder	12		
6 Cost of Bidding	12		
7 Site Visit	12		
		<b>E Bid Opening and Evaluation</b>	
<b>B Bidding Documents</b>		23 Bid Opening	22
8 Content of Bidding Documents	14	24 Process to be Confidential	22
9 Clarification on Bidding Documents	14	25 Clarification of Bids	23
10 Amendment of Bidding Documents	14	26 Examination of Bids and Determination of Responsiveness	23
<b>C Preparation of Bids</b>		27 Correction of Errors	23
11 Language of Bid	16	28 Evaluation and Comparison of Bids	24
12 Documents Comprising the Bid	16	<b>F Award of Contract</b>	
13 Bid Prices	17	29 Award Criteria	25
14 Currencies of Bid and Payment	17	30 Employer's Right to Accept any Bid and to Reject any or all Bids	25
15 Bid Validity	17	31 Notification of Award and Signing of Agreement	25
16 Bid Security	18	32 Performance Security	26
17 Alternative Proposals by Bidders	19	33 Advance Payment	26
18 Format and Signing of Bid	19	34 Corrupt or Fraudulent Practice	26

## A: GENERAL

### 1. Scope of Works

1.1 The Barwa Adda Expressway Limited, (hereinafter be referred to as the “Employer”) proposes to execute **Six-Laning of Barwa-Adda- Panagarh Section of NH-2 from km 398.240 to km 521.120 including Panagarh Bypass in the States of Jharkhand and West Bengal – “Supply & Installation of Retro Reflective Signage & Gantry boards at various locations between km 398.240 to km 521.120 in the States of Jharkhand and West Bengal.”** hereinafter referred to as the “Works”.

1.1.1 The works detailed herein is an Item Rate Contract basis. The indicative scope of work to be carried out by the successful Bidder, inter alia, includes the following but not limited to:

- i. Providing and fixing of micro-prismatic retro-reflectorized Sign Boards (3M India Ltd/ORAFOL MAKE) made of 4 mm thick ACP sheet riveted on MS angle iron frame of size (35x35x3) mm, back side of plate is painted in two coats of epoxy grey paint after etching treatment of plate on both sides. The face of ACP sheet is fully covered by retroreflective sheeting having the coefficient of retro reflection determined in accordance with type XI ASTM D 4956-01 standards and symbol in black by screen printing process. This plate is fixed on a mild steel post of pipe 75 mm OD (medium) (with hold fast of size 30 to 40 cm at bottom) (duly painted in alternate bands of 25 cm. black and white with 2 coats of superior quality of synthetic enamel paint after applying red oxide zinc chromate metal primer) duly welded to back frame of the sign plate, firmly fixed to the ground by means of properly designed foundation with M20 grade cement concrete minimum (60x60x75) cm below ground level as per approved drawing including labor and hire charges for machineries involved etc., complete as per Technical Specification Clause 801 and as directed by the Engineer
  - Cautionary Sign Board
  - Object Hazard Marker
  - Mandatory Sign Board
  - Informatory Single Post Sign Board
  - Facility information Single Post Sign Board
  - Informatory Direction/Dual Post
  - Informatory Direction/Dual Post

- ii. Providing and fixing of micro-prismatic retro-reflectorized Sign Boards (3M India Ltd/ORAFOL MAKE) made of 4 mm thick ACP sheet riveted on MS angle iron frame of size (40x40x3) mm, back side of plate is painted in two coats of epoxy grey paint after etching treatment of plate on both sides. The face of ACP sheet is fully covered by retroreflective sheeting, having the coefficient of retro reflection determined in accordance with Type XI ASTM D 4956-01 standards and letter/matter in similar type of sheeting or cut out in overlay film. This structure has fixing provisions to 2 Nos post of MS pipe 75mm OD heavy duty (with hold fast of size 30 to 40 cm at bottom) (duly painted in alternate bands of 25 cm black and white with 2 coats of superior quality of synthetic enamel paint after applying red oxide zinc chrome metal primer) and duly welded to back frame of sign plate, firmly fixed to the ground by means of properly designed foundation with M20 grade cement concrete minimum (60 cm x 60 cm x 75 cm) below ground level as per approved drawing including labor and hire charges for machineries involved etc, complete as per Technical Specifications Clause 801 and as directed by the Engineer
- Advance Direction signs size (1800X1500 mm)
  - Place Identification signs size (1200X900 mm)
- iii. Design, Supply and Fixing of Overhead and Cantilever structures for Sign Boards Steel work built up trusses of welded tubes including cutting and fixing in position, RCC M20 foundation, erection with the help of movable gantry crane and applying a coat of red oxide zinc chromate primer, and 2 coats of polymer based paint complete, welded and bolted including special shape of washers, as per contractor's design but excluding overhead Sign Board as per approved design (Enclosed as Design with Technical Specifications in Section 5 of RFP – Volume 1). Technical Specifications Clause 802 and as directed by the Engineer.
- iv. Supply and fixing of Micro Prismatic type Retro - Reflective sign plate (M/s 3M India Ltd/ORAFOL MAKE) made out of 4mm thick ACP sheet duly framed by MS angle iron (40x40x5) mm and additional vertical bracing at every 1.2 Mtr, on both sides the face of the plate is to covered with Blue/ Green Micro prismatic type Retro - Reflective sheeting and the matter & logo with same type of sheeting / cut out in overlay film with type XI ASTM D 4956-01 standard This plate is to be fixed on Overhead/ Cantilever structures with the help of G.I nut bolts complete, in all respects as per drawings Technical Specifications Clause 801, 802 and direction of the Engineer.
- v. Shifting of existing Sign Boards to designated approved locations

including carrying out necessary rectification on post foundation, Post painting and replacement of sheets in all respects and then installation of the repaired posts complete as per technical specification.

- vi. Providing and fixing ellipsoidal design height 800 to 900 mm above ground with 200 to 300 mm base which can be anchored onto the ground. MS Guide poles shall conform to type XI class C ASTM D 4956 -01 standard road delineators complete as per IRC 79:2019 Technical Specifications.
- vii. On back of the Signboard, following details are to be provided (Mandatorily)-
  - a. Supplier Name
  - b. Contractor Name
  - c. Original Manufacturer Name
  - d. Grade of Reflective Sheeting
  - e. Warranty Expiry Date
  - f. Date of Supply
- viii. The contractor/Supplier of the road signs should be an Authorized Agency of the Retro Reflective Sheeting Manufacturer Company and should submit an Authorization certificate from the principal manufacturer (3M/ORAFOL).
- ix. All display materials including Retro-reflective Sheeting shall be reflectorized type with high intensity retro-reflective sheeting conforming to ASTM D 4956-09, Type XI, as per specification Clause 6.7.3.3 and table 6.9 of IRC 64-2010. M/s 3M India Ltd/ORAFOL MAKE. All the texts, borders & symbols shall be digitally printed using technology printers recommended by sheeting manufacture or use the sign manufacturing method approved by IRC 67-2022.
- x. Testing facility of Retro-reflective Sheeting / Signage as per specification shall be provided at site for random check. Facility shall be made available when required for visiting the manufacturing unit. Background white Retro-reflective sheeting of Signage shall be made of Single piece Retro-reflective Sheeting (Including Gantry and Cantilevers structure) without any joint etc. Colored Retro-reflective Sheet shall be Single Sheet without any joints and shall be machine pasted. Signage shall be as per the IRC specification and shall have our prior approval. ACM thickness shall be 4mm as per Cl. 6.5.2 and Cl. 6.6 of IRC: 67 -2010.
- xi. A Certificate in original from the principal manufacturer of retro

reflective sheeting stating the material being supplied under the purchase order confirms to the standards specified for retro reflective sheeting along with the No. and is part of the original warranty at every time of Signage supply before installation. This Certificate shall be in the original letterhead of the Sheeting Principal Manufacturer (3M/ORAFOL).

- xii. In addition, 10 Years of OEM reflectivity Warranty Certificate of Type XI respectively to be submitted for satisfactory field performance of the finished sign with retro reflective sheeting as per the ASTM D4956 inclusive of the messages (Legends, Letters, Numerals, etc.), Images and borders by the respective Contractor/Supplier to the Engineer-In-Charge at the time of submission of bills. This Certificate shall be in the original letterhead of the Sheeting Principal Manufacturer (3M/ORAFOL).
- xiii. Post Installation, Retro-Reflectivity Test shall be conducted on the Signages & Ra values at all angles of the Sign Boards should pass minimum Co-efficient values as mentioned in the IRC- 67 (2022) MORTH Guidelines in the front of the concern Authorities & Consultant.
- xiv. The retro reflectivity test to be done free of cost every 2 years till the provided warranty period using Retro-Reflectometer and should submit the test report.

#### 1.1.2 **Defect Liability:**

Subsequent to completion of the scope of works, Contractor shall be responsible for any defect arising in the executed work for a period of **18 Months. The contractor shall also be responsible to undertake the OEM reflectivity warranty of minimum 10 years and should do assessment of the same every 2 years till end of warranty period.**

The successful Bidder shall have full regard and be responsible for the safety of the Works/road users and all Project Site operations and for all methods of design for temporary structures, construction and maintenance of the Works, the Project Road and the Facility, irrespective of any approval or consent by the Employer and cost for the same is deemed to be included in the Bid Price, as incidental to work.

The successful Bidder shall take full responsibility for operation and maintenance of the existing road & facilities thereto and for Traffic Management, in accordance with Annexure-5B of Technical Specifications of Section 5 from the Start Date. The cost of maintenance

of the road, Barricading, traffic management, markings and signs, look-out persons, construction of temporary cross-drainage and road diversion works, and other similar works needed during implementation of the Works are deemed to be included by the Bidder in the Bid Price, as incidental to work.

The successful Bidder shall carry out his activities in connection with the Contract in such a manner so as to comply with the Environmental Management Plan in accordance with Annexure-5A of Technical Specifications, Section 5 of Specifications and shall assume full responsibility for measures which are required to ensure such compliance and cost for the same is deemed to be included in the Bid Price, as incidental to work.

- 1.2 The Employer is now inviting bids for **Six-Laning of Barwa-Adda- Panagarh Section of NH-2 from km 398.240 to km 521.120 including Panagarh Bypass in the States of Jharkhand and West Bengal – “Supply & Installation of Retro Reflective Signage & Gantry boards at various locations between km 398.240 to km 521.120 in the States of Jharkhand and West Bengal.”** as defined in the Contract Data and referred to as “Works”.
- 1.3 The successful Bidder will be expected to complete the works by the Date as specified in the Contract Data and thereafter responsible for the defects for a period of 18 months.

2. Deleted.

### 3. Eligible Bidders

- 3.1 All the Bidders having minimum 5 years work experience in supply & installation of Retroreflective Signages boards and Overhead Gantry structure. An experience certificate confirming the same shall be submitted in response to the RFP.
- 3.2 All the Bidders who will produce the certificate that they have successfully executed similar works not less than Rs. 3.5 Cr. during any one year of the last 3 Financial Years are eligible to bid.

*The bidder has to provide details of work executed during last 3 years as per following table which shall be supported by requisite supporting documents i.e. Work Completion Certificate / Payment Received / Agreements/Work Order etc.*

<b>Sr. No.</b>	<b>Financial Year</b>	<b>Details of work executed</b>
1	FY 22-23	
2	FY 21-22	
3	FY 20-21	

- 3.3 All the bidders who produce the turnover certificate of the Auditor that they have Average Annual turnover of Rs 3.5 Cr. during ***last 3 years are eligible to bid***. This data **should be supported by Auditor Certificate & Balance Sheet** of the company.
- 3.4 Bidders should not have abandoned any of their contracts and should not be under a declaration of ineligibility or blacklisted for corrupt, fraudulent and coercive practices or poor quality or delayed implementation of any work by the Government of India (GoI), State Governments, Employer, Developer and/or statutory authorities like National Highways Authority of India.

#### 4. **Qualification of the Bidder**

- 4.1 Bidders should submit, with their Bids, qualification information regarding the Sign Boards works completed by them as defined in clause 3.1 & 3.2 and other information correct as on 28 days prior to last date of submission of Bids as per Form 2A, Qualification Information and Other Forms of Section 2.
- 4.2 All Bidders shall also include the following information and documents with their Bids in the formats prescribed, wherever applicable, in this Bidding Document:
- (a) the certificate that they have successfully completed the requisite minimum value of works defined in clause 3.1 and 3.2 during last 3 financial years;
  - (b) the certificate that they have requisite average Annual Turnover for participation in Bid in **during last 3 financial years.**
  - (c) written Power of Attorney authorizing the signatory of the Bid;
  - (d) latest Income Tax clearance certificate from the concerned department;
  - (e) major items of construction equipment proposed to carry out the Contract; {as per Clause 4.4 (a)}
  - (f) an undertaking confirming the validity of above information
  - (g) Deleted
  - (h) Information regarding any litigation or arbitration resulting from contracts executed by the Bidder in the last three years or currently under execution.

The information shall include the names of the parties concerned, the disputed amount, duration of dispute, cause of litigation, matter in dispute and other relevant details; the Bidders shall also submit the information regarding debarring / expelling of Bidder or abandonment of work by Bidder (as per S. Nos. 1.4 & 1.5 of Form 2A of Section 2);

- (i) deleted
- (j) the proposed methodology and program for the Works including Environment and Traffic Management Plans (barricading etc.), backed with equipment and resources planning and deployment, duly supported with broad calculations and quality control procedures proposed to be adopted, justifying the execution and completion of the Work as per Contract Specifications within the stipulated period of completion. The Bidder shall also submit his proposed Works Program and Monthly Cash Flow Forecast in forms at Annexures 3A and 3B, respectively;

4.3 **Joint Venture: - Joint Venture (JV) is *not allowed*.**

4.4 Each Bidder shall demonstrate:

- (a) Section wise availability of key construction equipment as minimum required is indicated in the Schedules at Annexures–1A. The equipment can be either owned or leased or rented. However, it is entirely the responsibility of the Contractor to deploy sufficient Plant and Equipment to ensure satisfactory compliance with his obligations under the Contract, during the execution of Works and for Maintenance Works/DLP as may be required at the Site.

All Equipment provided by the Contractor at the site of Works shall be of the quality and capacity as approved by the Employer and shall be deemed to be exclusively intended for the execution of the Works, and all these shall be operated, used and maintained in a manner acceptable to the Employer.

- (b) Deleted

4.5 Even though the Bidders meet the criteria set out above, they are subject to be declared non-responsive if they have:

- (a) made misleading or false representations in the forms, statements and attachments submitted in proof of the qualification requirements; and/or
- (b) record of poor performance such as abandoning the works, not properly completing the contract, inordinate delays in completion, litigation history, or financial failures etc.; and/or
- (c) have been blacklisted by any statutory agency/employer during the intervening period between qualification and award of works; and/or
- (d) Participated in bidding for any work and has quoted unreasonably high bid prices and could not furnish rational justification to the Employer.



5. **One Bid per Bidder**

Each Bidder shall submit only one Bid for the work

6. **Cost of Bidding**

The Bidder shall bear all costs associated with the preparation and submission of his Bid, and the Employer will in no case be responsible and liable for those costs.

7. **Site visit**

The Bidder, at the Bidder's own responsibility and risk is encouraged to visit and examine the site and its surroundings and obtain all information that may be necessary for preparing the Bid and entering into a contract for the Works. The costs of visiting the site shall be at the Bidder's own expense and no claim shall be eligible in this regard.

## **B: BIDDING DOCUMENTS**

### **8. Content of Bidding Document**

8.1 The set of Bidding Documents consist of documents listed in the Table below and amendment/addenda issued in accordance with Clause 10 of this Section. A copy of Section 6 (Bill of Quantities) will be available along with the Bidding Documents to the Bidders to facilitate the Bidder to submit the copy of the duly filled Bill of Quantities.

<b>Invitation for Bid</b>		
Section 1	Instructions to Bidders	Volume 1
Section 2	Qualification Information and Other Forms	
Section 3	Part–I: General Conditions of Contract Part–II: Special Conditions of Contract	
Section 4	Contract Data	
Section 5	Technical Specifications & Design	
Section 6	Bill of Quantities	Volume 2
Section 7	Securities and Other Forms	

8.2 One copy of each of Volumes 1 and 2 can be downloaded from the site. Documents to be furnished by the Bidder should be in the formats prescribed in Sections 2, 6 and 7 of the Bid Document and addendum issued pursuant to Clause 10.

### **9. Clarification on Bidding Documents**

9.1 A Bidder requiring any clarification of the Bidding Documents may notify the Employer in writing through post, fax or e-mail at the Employer's address indicated in the Invitation to Bid. The Employer will respond to any request for clarification which he has received at least 3 days before the last date for receipt of Bids. Copies of the Employer's response will be uploaded on the web site at **[www.itnlindia.com](http://www.itnlindia.com)**.

9.2 Any modification of the Bidding Documents listed in Clause 8.1 which may become necessary as a result of the clarification given to Bidders shall be made by the Employer exclusively through the issue of an Addendum pursuant to Clause 10.

### **10. Amendment of Bidding Documents**

10.1 Before the deadline for submission of bids, the Employer may modify the Bidding Documents by issuing addenda.

10.2 Any addendum thus issued shall be part of the Bidding Documents and shall be communicated at the employer's web site. All such addenda shall become an integral part of the Bidding Document and it shall be incorporated in Bid prices

and duly signed, stamped and submitted along with the Bid documents. Bid shall be deemed to be incomplete if the addendum (addenda) is (are) not enclosed duly signed by the Bidder along with the Bid documents.

## **C: PREPARATION of BIDS**

### **11. Language of the Bid**

11.1 All documents relating to the Bid shall be in the English language.

### **12. Documents Comprising the Bid**

12.1 The Bid submitted by the Bidder shall comprise the following:

- Outer envelope marked as per Sub Clause 19.2 in two sets as “ORIGINAL” and “COPY”.

In outer envelopes (ORIGINAL and COPY) the following two inner envelopes marked (I) and (II) along with the other information/materials and bearing identification and address as per Sub Clause 19.2.

#### **Envelope (I) – marked as Bid security and qualification information**

- a. Bid Security in prescribed Form 7B of Section 7.
- b. Qualification Information Form/certificates, undertaking etc. (in prescribed Forms 2A, 2B and 2C of Section 2).

#### **Envelope (II) – marked as Form of Bid and Priced Bill of Quantities**

- c. The Form of Bid (in prescribed Form 7A of Section 7). The Form of Bid needs to be submitted with & bid amount in paragraph 1. (Preferably on letterhead of the Bidder).
- d. Bill of Quantities needs to be on letterhead of the Bidder. Priced Bill of Quantities for Sign Boards works is specified in Section 6 (Annexure-1). The same needs to be submitted inclusive of GST and in line with clause 13.

And any other material required to be submitted by Bidders in accordance with these Instructions to Bidders. The documents listed under Sections 2, 6 and 7 of Sub Clause 8.1 shall be filled in without exception.

12.2 The Bidder shall submit the Bids in two separate envelopes. One envelope marked (I) shall have submissions as per Sub Clause 12.1 (a) and (b). The second envelope marked (II) shall contain submissions as per Sub Clause 12.1 (c) and (d). The Bidder shall prepare two copies of each of these submissions, marking them “ORIGINAL” and “COPY” respectively, which shall be sealed and put in a covered envelope accordance with the Sealing and Marking instructions in Clause 19.

12.3 Following documents, which are not submitted with the bid, will be deemed to be part of the bid:

	<u>Invitation for Bids</u>
Section 1	Instructions to Bidders
Section 3	General Conditions of Contract and Special Conditions of Contract
Section 4	Contract Data
Section 5	Technical Specifications & Design

### 13. **Bid Prices**

13.1 The Contract shall be for the Works as described in Contract Data, based on the priced Bill of Quantities for the Works submitted by the Bidder in prescribed Bid Form 7A of Section 7 and Annexure-1 of Section 6.

13.2 The Bidder shall fill in rates and prices and line-item total (both in figures and words) for all items of the Works described in the **Bill of Quantities** along with total Bid Price (both in figures and words) for Sign Boards works. Items for which no rate or price is entered by the Bidder will not be paid by the Employer when executed and shall be deemed to be covered by the other rates and prices in the Bill of Quantities. Corrections, if any, shall be made by crossing out, rewriting and initialing, in ink.

13.3 All duties, taxes, and other levies payable by the Contractor under the Contract, or for any other cause shall be included in the rates, prices and total Bid Price submitted by the Bidder.

13.4 Deleted

### 14. **Currencies of Bid and Payment**

14.1 The unit rates and the prices shall be quoted by the Bidder entirely in Indian Rupees, and payment shall be made in Indian Rupees.

### 15. **Bid Validity**

15.1 Bids shall remain valid for a period not less than sixty (60) days after the deadline date for Bid submission, specified in Clause 20. **A bid valid for a shorter period shall be rejected by the Employer as non-responsive.**

15.2 In exceptional circumstances, prior to expiry of the original time limit, the Employer may request the Bidders to extend the period of validity for a specified additional period. The request and the Bidders' responses shall be made in writing or by email. A Bidder may refuse the request without forfeiting his Bid security. A Bidder agreeing to the request will not be required or permitted to modify his Bid but will be required to extend the validity of his Bid security for a period of the extension, and in compliance with Clause 16 in all respects.

## 16. Bid Security

16.1 The Bidder shall furnish, as part of his Bid, a Bid Security for an amount mentioned in Invitation for Bid. **This Bid Security shall be in favor of “Barwa Adda Expressway Limited”** Payable at Mumbai

Account Details:

Bank Name: Bank of Baroda

Name of Account: Barwa Adda Expressway Limited Escrow Account

Account Number: 29100200000238

Branch: CFS Ballard Estate

IFSC Code: BARB0CFSBAL

and may be in one of the following forms:

- A Bank Guarantee, in the prescribed format is acceptable from the following institutions located in India:
  - (a) State Bank of India or its subsidiaries;
  - (b) Any Indian Nationalized /Scheduled Bank;
  - (c) Foreign Bank with operations in India provided the net worth in respect of the Indian operations shall not be less than ₹ 500 Cr. as per the latest Annual Report of the Bank and that Bank Guarantee is issued by a branch in India.
- Bankers' cheque or Demand draft in favor of “Barwa Adda Expressway Limited” payable at Mumbai.

16.2 Bank guarantees issued as surety for the Bid should be valid for 60 days beyond the validity of the Bid.

16.3 Any Bid not accompanied by an acceptable Bid Security and not secured as indicated in Sub Clauses 16.1 and 16.2 shall be rejected by the Employer as non-responsive.

16.4 The Bid Security of unsuccessful Bidders other than the evaluated responsive lowest three Bidders will be returned within 30 days of the completion of the bid evaluation process and within the bid validity period, specified in Sub Clause 15.1. The Bid Security of two of the lowest three Bidders, other than the successful Bidder, shall be returned after signing of the Contract Agreement with the successful Bidder.

16.5 The Bid Security of the successful Bidder will be discharged when the Bidder has signed the Agreement.

- 16.6 The Bid Security may be forfeited
- a. if the Bidder withdraws the Bid after Bid opening during the period of Bid validity;
  - b. if the Bidder does not accept the correction of the Bid Price, pursuant to Clause 27; or
  - c. in the case of a successful Bidder, if the Bidder fails within the specified time limit to sign the Agreement

**17. Alternative Proposals by Bidders**

- 17.1 Conditional offers or alternative proposals will not be considered.

**18. Format and Signing of Bid**

- 18.1 The Bidder shall prepare one original and one copy of the documents comprising the Bid as described in Clause 12, and clearly marked “ORIGINAL” and “COPY” as appropriate. In the event of discrepancy between them, the original shall prevail.
- 18.2 The original and copy of the Bid shall be typed or written in indelible ink and shall be signed by a person or persons duly authorized to sign on behalf of the Bidder, pursuant to Sub Clauses 4.2 and 4.3. All pages of the Bid where entries or amendments have been made shall be initialed by the person or persons signing the Bid.
- 18.3 The Bid shall contain no alterations or additions, except those to comply with instructions issued by the Employer, or as necessary to correct errors made by the Bidder, in which case such corrections shall be initialed by the authorized signatory.
- 18.4 The Bidder shall furnish information as described in the Form of Bid (in Form 7A of Section 7) on commissions or gratuities, if any, paid or to be paid to agents relating to this Bid, and to contract execution if the Bidder is awarded the contract.
- 18.5 Deleted

## D: SUBMISSION OF BIDS

### 19. Sealing and Marking of Bids

- 19.1 The Bidder shall seal the original and copy of the Bid together with the soft copy duly filled in separate envelopes as described in Sub Clause 12.2, duly marking the envelopes as "**ORIGINAL**" and "**COPY**". These envelopes (called as inner envelopes) shall then be put inside **one outer envelope**.

In addition to that soft copy of above bid also to be sent on email id: [itnl.projectbids@itnlindia.com](mailto:itnl.projectbids@itnlindia.com), and the bids heavy in size can be submitted via link.

- 19.2 The **outer** and two **inner** (marked (I) and (II)) envelopes shall be

- a) addressed to the Employer at the following address:

**Barwa Adda Expressway Limited**

The IL&FS Financial Center, Plot C-22, G Block, Bandra Kurla Complex, Mumbai- 400051, Tel.: +91 022-26593609,

and

- b) bear the following identification on **Outer Single Envelope**:

**“Six-Laning of Barwa-Adda- Panagarh Section of NH-2 from km 398.240 to km 521.120 including Panagarh Bypass in the States of Jharkhand and West Bengal – “Supply & Installation of Retro Reflective Signage & Gantry boards at various locations between km 398.240 to km 521.120 in the States of Jharkhand and West Bengal.”**

**DO NOT OPEN ON OR BEFORE 1800 Hrs on July 21, 2023**

- 19.3 In addition to the identification required in Sub Clause 19.2, the inner envelopes shall indicate the name and address of the Bidder to enable the Bid to be returned unopened in case it is declared late, pursuant to Clause 21.
- 19.4 If the outer envelope is not sealed and marked as above, the Employer will assume no responsibility for the misplacement or premature opening of the Bid.

### 20. Deadline for Submission of the Bids

- 20.1 Completed Bids must be received by the Employer at the address specified above no later than **1800 Hrs IST on July 21, 2023** for Soft Copy & 1800 Hrs IST on **July 24, 2023** for Hard Copy. In the event of the specified date for the



submission of Bids being declared a holiday for the Employer, the Bids will be received up to the appointed time on the next working day.

- 20.2 The Employer may extend the deadline for submission of Bids by issuing an amendment in accordance with Clause 10, in which case all rights and obligations of the Employer and the Bidders previously subject to the original deadline will then be subject to the new deadline.

**21. Late Submission of Bids**

- 21.1 Any Bid received by the Employer after the deadline prescribed in Clause 20 will be returned unopened to the Bidder.

**22. Modification and Withdrawal of Bids**

- 22.1 Bidders may modify or withdraw their Bids by giving notice in writing before the deadline prescribed in Clause 20.

- 22.2 Each Bidder's modification or withdrawal notice shall be prepared, sealed, marked, and delivered in accordance with Clauses 18 and 19, with the outer and inner envelopes additionally marked "**MODIFICATION**" or "**WITHDRAWAL**", as appropriate.

- 22.3 No Bid may be modified after the deadline for submission of Bids.

- 22.4 Withdrawal or modification of a Bid between the deadline for submission of Bids and the expiration of the original period of Bid validity specified in Clause 15.1 or as extended pursuant to Clause 15.2 may result in the forfeiture of the Bid security pursuant to Clause 16.

- 22.5 Bidders may offer discount or modify the prices of their Bids only by submitting Bid modifications in accordance with this clause or included in the original Bid submission.

## **E: BID OPENING and EVALUATION**

### **23. Bid Opening**

- 23.1 The Employer will open all Bids received (except those received late), including modifications made pursuant to Clause 22, in the presence of the Bidders or their representatives who choose to attend at the time, date and place specified in Clause 20. In the event of the specified date of Bid opening being declared a holiday for the Employer, the Bids will be opened at the appointed time and place on the next working day.
- 23.2 Envelopes marked “**WITHDRAWAL**” shall be opened and read out first. Bids for which an acceptable notice of withdrawal has been submitted pursuant to Clause 22 shall not be opened. Subsequently all envelopes marked “**MODIFICATION**” shall be opened and the submissions therein read out in appropriate detail.
- 23.3 The Employer will open the outer envelope of all the bids received for the project (except those received late). Subsequently, **Envelope (I)** marked containing **Bid security and qualification information** as per Sub Clause 12.1 (a) and (b) shall be opened for all the Bidders.
- 23.4 On confirming the Bid security, **Envelope (II)** marked containing **the Form of Bid and priced Bill of Quantities** as per Sub Clause 12.1 (c) and (d) shall be opened for all the Bidders. The Bidder’s names, the Bid prices, the total amount of the Bid, any discounts, Bid modifications and withdrawals, the presence or absence of Bid security, and such other details as the Employer may consider appropriate, will be announced by the Employer at the opening. Determination of the lowest Bidder shall be done after evaluation of the Bids as per terms of the Bid Document.
- 23.5 No bid shall be rejected at bid opening except for late bids pursuant to Clause 21 and conditional bids. Bids (and modifications) sent pursuant to Clause 22 that are not opened and read out at bid opening will not be considered for further evaluation regardless of the circumstances. Late and withdrawn bids will be returned un-opened to Bidders.

### **24. Process to be Confidential**

- 24.1 Information relating to the examination, clarification, evaluation, and comparison of Bids and recommendations for the award of a contract shall not be disclosed to Bidders or any other persons not officially concerned with such process until the award to the successful Bidder has been announced.

**25. Clarification of Bids**

- 25.1 To assist in the examination, evaluation, and comparison of Bids, the Employer may, at his discretion, ask any Bidder for clarification of his Bid, including breakdowns of all the unit rates. The request for clarification and the response shall be in writing or by cable, but no change in the price or substance of the Bid shall be sought, offered, or permitted except as required to confirm the correction of arithmetic errors discovered by the Employer in the evaluation of the Bids in accordance with Clause 27. In case any Bidder refuses to furnish any clarification sought by the Employer, which may affect his Bid Price, then his bid shall be liable to be treated as non-responsive.
- 25.2 Subject to Sub Clause 25.1, no Bidder shall contact the Employer/its representatives on any matter relating to the Bid from the time of the bid opening to the time the contract is awarded. If the Bidder wishes to bring additional information to the notice of the Employer, he shall do so in writing.
- 25.3 Any effort by the Bidder to influence the Employer in the Employer's bid evaluation, bid comparison or contract award decisions may result in the rejection of the Bidder's Bid.

**26. Examination of Bids and Determination of Responsiveness**

- 26.1 During the detailed evaluation of Bids, the Employer will determine whether each Bid (a) meets the eligibility criteria defined in Clauses 3 and 4, (b) has been properly signed; (c) is accompanied by the required securities, and (d) is substantially responsive to the requirements of the Bidding documents.
- 26.2 A substantially responsive Bid is one which conforms to all the terms, conditions, and specifications of the Bidding Documents, without material deviation or reservation. A material deviation or reservation is one (a) which affects in any substantial way the scope, quality, or performance of the Works; (b) which limits in any substantial way, inconsistent with the Bidding Documents, the Employer's rights or the Bidder's obligations under the Contract; or (c) whose rectification would affect unfairly the competitive position of other Bidders presenting substantially responsive Bids.
- 26.3 If a Bid is not substantially responsive, it will be rejected by the Employer, and shall not subsequently be made responsive by correction or withdrawal of the non-conforming deviation or reservation.

**27. Correction of Errors**

- 27.1 Bids determined to be substantially responsive will be checked by the Employer for any arithmetic errors. Errors will be corrected by the Employer as follows:

- a. where there is a discrepancy between the rates in figures and in words, the rate in words will govern; and
  - b. where there is a discrepancy between the unit rate and the line-item total resulting from multiplying the unit rate by the quantity, the unit rate as quoted will govern.
  - c. in case different rates are furnished in different sections of the Bill of Quantities for the same item, then the lowest rate for the item shall prevail for all the places where the item is appearing.
- 27.2 The amount stated in the Bid will be corrected by the Employer in accordance with the above procedure for the Correction of Errors and, with the concurrence of the Bidder. Such adjusted Bid Price shall be considered as binding upon the Bidder. If the Bidder does not accept the corrected amount, the Bid will be rejected and the Bid Security may be forfeited in accordance with Sub Clause 16.6 (b).

**28. Evaluation and Comparison of Bids**

- 28.1 The Employer will evaluate and compare only the Bids determined to be substantially responsive in accordance with Clause 26.
- 28.2 In evaluating the Bids, the Employer will determine for each Bid the evaluated Bid Price by adjusting the Bid Price as follows:
- a. making any correction for errors pursuant to Clause 27; or
  - b. making an appropriate adjustment for any other acceptable variations, deviations; and
  - c. making appropriate adjustments to reflect discounts or other price modifications offered in accordance with Sub Clause 22.5.
- 28.3 The Employer reserves the right to accept or reject any variation, deviation, or alternative offer. Variations, deviations, and alternative offers and other factors which are in excess of the requirements of the Bidding documents or otherwise result in unsolicited benefits for the Employer shall not be taken into account in Bid evaluation.
- 28.4 Deleted
- 28.5 If the Bid of the successful Bidder is unbalanced in relation to the Employer's estimate of the cost of work to be performed under the Contract, the Employer may require the Bidder to produce detailed rate analysis for any or all items of the Bill of Quantities, to demonstrate the internal consistency of those rates with the construction methods and schedule proposed.

## F: AWARD OF CONTRACT

### 29. Award Criteria

29.1 Subject to Clause 30, the Employer will award the Contract to the Bidder whose Bid has been determined to be substantially responsive to the Bidding documents and who has offered the Lowest Evaluated Bid Price, provided that such Bidder has been determined to be (a) eligible in accordance with the provisions of Clause 3, and (b) qualified in accordance with the provisions of Clause 4.

### 1. Employer's Right to accept any Bid and to reject any or all Bids

1.1 Notwithstanding Clause 29, the Employer reserves the right to accept or reject any Bid, and to cancel the Bidding process and reject all Bids, at any time prior to the award of Contract, without thereby incurring any liability to the affected Bidder or Bidders or any obligation to inform the affected Bidder or Bidders of the grounds for the Employer's action.

### 2. Notification of Award and Signing of Agreement

2.1 The Bidder who's Bid has been accepted will be notified of the award after approval of NHAI/Lenders by the Employer prior to expiration of the Bid validity period by cable, telex or facsimile, and confirmed by registered letter. This letter (hereinafter and in the Conditions of Contract called the "Letter of Acceptance") (Form 7C of Section 7) will state the sum that the Employer will pay the Contractor in consideration of the execution, completion, and maintenance of the Works by the Contractor as prescribed by the Contract (hereinafter and in the Contract called the "Contract Price").

2.2 The notification of award through the Letter of Acceptance will signify the intention of the Employer to enter into a contract, subject to the furnishing of a Performance Security by the Bidder in accordance with the provisions of Clause 32.

2.3 The Agreement (Form 7F of Section 7) will incorporate all clarifications sought and submitted, and all agreements between the Employer and the successful Bidder. It will be signed by the Employer and kept ready in his office for signatures of the successful Bidder within 14 days following the issue of the Letter of Acceptance.

2.4 Upon Signing of Contract by the successful Bidder, the Employer will promptly notify the other Bidders that their Bids have been unsuccessful and refund their bid security.

## **Performance Security and Tender conditions**

2.5 Within 7 days of receipt of the Letter of Acceptance, the successful Bidder shall deliver to the Employer a Performance Security in the form of an unconditional Bank Guarantee for an amount equivalent to 3% of the Contract Price (Excluding GST) for works, in accordance with Clause 28.5 of ITB and Clause 48 of General Conditions of Contract of Section 3. The Bank Guarantee, in the prescribed format (Form 7B of Section 7), is acceptable from the following institutions located in India:

- a. State Bank of India or its subsidiaries;
- b. Any Indian Nationalized /Scheduled Bank;
- c. IDBI Bank or Axis Bank or ICICI Bank or HDFC Bank or Yes Bank; or
- d. Foreign Bank with operations in India provided the net worth in respect of the Indian operations shall not be less than ₹ 500 crores as per the latest Annual Report of the Bank and that Bank Guarantee

2.6 Deleted

2.7 Failure of the successful Bidder to comply with the requirements shall constitute sufficient grounds for cancellation, cause for annulment of the award, forfeiture of the Bid Security, Performance Bank Guarantee and any such other remedy the Employer may take under the Contract, and the Employer may resort to awarding the Contract to any other evaluated Bidder.

## **3. Advance Payment**

3.1 Deleted

## **4. Corrupt or Fraudulent Practices**

4.1 The Employer requires that the Bidders/Contractors, observe the highest standard of ethics during the procurement and execution of the Contracts. In pursuance of this policy, the Employer:

- a) defines, for the purposes of this provision, the terms set forth below:
  - i. “corrupt practice” means the offering, giving, receiving or soliciting of anything of value to influence the action of Employer/its representatives in the procurement process or in contract execution;
  - ii. “fraudulent practice” means a misrepresentation of facts in order to influence a procurement process or the execution of a contract to the detriment of the Employer, and includes collusive practice among Bidders (prior to or after bid submission) designed to establish Bid Prices at artificial non-competitive levels and to deprive the Employer of the benefits of free and open competition;
  - iii. “coercive practice” means harming or threatening to harm, directly or indirectly, persons or their property to influence their participation in the procurement process or affect the execution of the Contract.

- b) will reject a proposal for award if the Employer determines that the Bidder recommended for award has engaged in corrupt, fraudulent or coercive practices in competing for the contract in question;
- c) will declare a firm ineligible, either indefinitely or for a stated period of time, if the Employer at any time determines that the firm has engaged in corrupt, fraudulent or coercive practices in competing for, or in executing, contracts.

**Annexure – 1A**

*(Please refer Sub Clause 4.4 (a) of ITB)*

**Schedule of Minimum Key Construction Plant and Equipment required to be mobilized by Contractor for the works**

<b>Sr. No.</b>	<b>Type of Equipment</b>	<b>Plant &amp; Equipment Nos.</b>
<b>1</b>	<b>Hydra (Crane) of 15 Ton capacity or truck mounted bucket lift</b>	<b>1</b>
<b>2</b>	<b>JCB</b>	<b>1</b>
<b>3</b>	<b>Auger</b>	<b>1</b>
<b>4</b>	<b>Tractor</b>	<b>1</b>
<b>5</b>	<b>Drilling machine</b>	<b>1</b>

**Note:**

*The Bidder must mobilize scope wise minimum resources as tabulated above. i.e. Resources to be deployed for respective sections shall be separate from each other, in case work to be started and implemented in various sections at the same time.*

*Apart from above, minimum equipment, the Contractor shall also mobilize additional equipment / plant / machinery for execution of above works.*

*The bidder must produce the documentary evidence in support of his owning/leased/ rented of the above equipment. In case the bidder proposes to hire or take the above equipment on lease, he should, along with the lease/rent agreement, attach the proof of ownership of these equipment with the company/ entity from whom the equipment are proposed to be hired on lease/ rent.*



**SECTION 2:**

**QUALIFICATION INFORMATION  
AND OTHER FORMS**

<b>Table of Forms</b>	<b>Description</b>	<b>Page No</b>
<b>Form 2A</b>	<b>Qualification Information</b>	<b>33-35</b>
<b>Form 2B</b>	<b>Undertaking confirming evidence of access or availability of credit facilities</b>	<b>36</b>
<b>Form 2C</b>	<b>Letter from bidder to bankers authorizing them to provide information to Barwa Adda Expressway Limited /Its Representatives</b>	<b>37</b>

### QUALIFICATION INFORMATION

The information to be filled in by the Bidder in the following pages will be used for purposes of the Qualification Information as mentioned in Clause 4 of the Instructions to Bidders. (Separate pages with required details shall be attached)

**1. Details of Bidder**

Name of Bidder/ Address/ Telephone/ Fax/ Email/ Contact Person and Designation

**1.1. Constitution or legal status of Bidder**

*[Attach copy]*

Place of registration: \_\_\_\_\_

Principal place of business: \_\_\_\_\_

Power of attorney in favor of signatory of Bid (Attach copy)

**1.2. Availability of Contractor's Equipment should be listed below for carrying out the Works. Contractor is to fill the following items regarding the availability of Equipment. The minimum requirement is available at Clause 4.4 (a) of ITB.**

Item of equipment	Minimum Requirement		Availability proposals				Remarks / Make
	No	Capacity	Nos	Capacity	Condition	Owned/ Leased/ to be procured	

**1.3. Information on litigation history in which the Bidder is involved**

{Refer ITB Clause 4.2 (i)}-

Item Head	Litigation 1	Litigation 2
Name of Employer		
Month/Year of origin		
Cause of Litigation/ Matter in Dispute		
Disputed Amount (Current Value in Indian Rupees)		
Resolved or pending resolution		
Award <i>For</i> or <i>Against</i>		

Actual Amount Awarded (Current Value in Indian Rupees)		
Other Claims Made, Settled/ Rejected		

1.4. Information regarding current litigation, debarring / expelling of bidder or abandonment of work by bidder; {(Refer ITB Clause 4.2 (i)}

1	(a)	Has the Bidder or its constituent partners a history of litigation/arbitration	Yes/No
	(b)	If yes, give details	
2	(a)	Has the Bidder or any of its constituent partners been debarred/expelled by any Agency in India, during the last 3 years as on the date of application	Yes/No
	(b)	If yes, give details	
3	(a)	Has the Bidder or any of its constituent partners abandoned any contract work in India during the last 3 years	Yes/No
	(b)	If yes, give details	
4	(a)	Has the Bidder or any of its constituent partners been declared bankrupt during the last 3 years	Yes/No
	(b)	If yes, give details, including present status	

Note: If any information in this schedule is found to be incorrect or concealed, at any time including after the award of works, the Bidder's bid will be treated as non-responsive, and action taken accordingly.

1.1. (A) Work performed as prime contractor/sub-contractor, work performed in the past as a nominated/approved sub- contractor provided further that all other qualification criteria are satisfied (in the same name) of a similar nature during the last 3 years.

Project Name	Name of the Employer*	Description & Scope of work	Contract No.	Value of Contract (₹ Crore)	Value of works completed	Role of Bidder/% of participation	Date of issue of work order	Stipulated period of completion	Actual date of completion *

**Information on works in progress and works likely to be awarded.**

**(B) Current Commitments and Works in Progress**

S N	Descripti on of Work	Plac e & State	Name of the Emplo yer	Contra ct No. and Date	Value of Contra ct (₹ Cr.))	Stipulate d Period of Comple tion Date	Value of works complet ed (₹ Cr.) @	Value of Works Remaini ng to be complete d (₹ Cr.)	Anticipat ed Completi on Date	Role of Bidder* and Remarks
	TOTAL									

**(C) Contracts for which Bids already submitted and are likely to be awarded**

Sl No	Descripti on of Work	Place & State	Name of the Employ er	Estimated Value of Contract ₹ Crores)	Stipulated Period of Completi on	Date when Decision is expected	Role of Bidder* and Remarks
	TOTAL						

Note:

@ : In case of currencies other than Indian Rupees, please indicate the value of works in the original currency as well as Indian Rupees and also the exchange rate assumed.

\*: Specify whether works were executed as Main Contractor, and Sub-Contractor or as JV Partner, along with their share.

**1.6.1. Suitable certification from Employers to be necessarily attached as part of this Appendix.**

**2. Deleted**

**SAMPLE FORMAT FOR EVIDENCE OF ACCESS TO OR AVAILABILITY OF  
CREDIT FACILITIES**

**Deleted**

**SAMPLE FORMAT FROM BIDDER TO BANKERS AUTHORIZING THEM TO  
PROVIDE INFORMATION TO BARWA ADDA EXPRESSWAY LIMITED / ITS  
REPRESENTATIVES**

To  
Name of Bank/Address/City

Dear Sirs:

We have recently submitted a Bid to Barwa Adda Expressway Limited for implementing the Works **“Six-Laning of Barwa-Adda- Panagarh Section of NH-2 from km 398.240 to km 521.120 including Panagarh Bypass in the States of Jharkhand and West Bengal – Supply & Installation of Retro Reflective Signage & Gantry boards at various locations between km 398.240 to km 521.120 in the States of Jharkhand and West Bengal.** We hereby authorize you to provide all information/data readily about us and our credit status, as may be required by Barwa Adda Expressway Limited and you need not seek any clearance/opinion from us for providing the information/data to Barwa Adda Expressway Limited and/or its authorized representatives.

Sincerely,

\_\_\_\_\_  
Authorized Signatory

### **SECTION 3:**

<b>Part No</b>	<b>Description</b>	<b>Page no</b>
<b>Part I</b>	<b>General conditions of contract</b>	<b>41 - 63</b>
<b>Part II</b>	<b>Special Conditions of Contract</b>	<b>65-70</b>

## SECTION: 3

### PART – I: GENERAL CONDITIONS OF CONTRACT

#### Table of Contents

	Page No.		Page No.
<b>A General</b>		<b>C Quality Control</b>	
1 Definitions	41	30 Identifying Defects	53
2 Interpretation	43	31 Tests	53
3 Language and Law	43	32 Correction of Defects	53
4 Employer's Duties and Employer	43	33 Uncorrected Defects	54
5 Delegation	44	<b>D Cost Control</b>	
6 Communication	44	34 Bill of Quantities	55
7 Subcontracting	44	35 Changes in the Quantities	55
8 Other Contractors	44	36 Variations	55
9 Personnel	44	37 Payments for Variations	55
10 Employer's & Contractor's Risks	45	38 Cash Flow Forecasts	56
11 Employer's Risks	45	39 Payment Certificates	56
12 Contractor's Risks	45	40 Delayed & Disputed Payments	57
13 Insurance	45	41 Compensation Events	57
14 Contractor to Construct the Works and Works to be Completed by Contract Completion Date	46	42 Tax	57
15 Safety, Security and Protection of the Environment	46	43 Currencies	57
16 Working Drawings	47	44 Change in Cost and Legislation	57
17 Approval by the Employer	47	45 Liquidated Damages and Penalty	61
18 Safety of Traffic	47	46 Deleted	61
19 Discoveries	47	47 Advance Payment	61
20 Possession of the Site	47	48 Securities	62
21 Access to the Site	48	49 Cost of Maintenance	62
22 Instructions	48	<b>E Finishing the Contract</b>	
23 Disputes	48	50 Completion	63
24 Procedure for Disputes – Arbitration	48	51 Taking Over	63



<b>B</b>	<b>Time Control</b>		52	Final Account	63
25	Program	49	53	As Built Drawings and Maintenance Manuals	64
26	Extension of the Construction works Completion Date	49	54	Termination	64
27	Delays Ordered by the Employer	51	55	Payment upon Termination	65
28	Management Meetings	51	56	Property	65
29	Early Warning	52	57	Release from Performance	65
			58	Details to be Confidential	66
			59	Life-saving Appliances and First-aid Equipment	66

## PART – I GENERAL CONDITIONS OF CONTRACT (GCC)

### A: GENERAL

The Contractor acknowledges the fact that the Concession Agreement between NHAI & the Concessionaire is always binding and terms of this Agreement are on back to back basis with the Concession Agreement (limited to the Scope defined in this Agreement) and in case of any discrepancy in whatsoever matter, the clauses of Concession Agreement shall prevail over & above this Agreement and the decision of NHAI/Independent Engineer (IE) shall be binding to all the parties to this Agreement.

#### 1. Definitions

- 1.1. Terms which are defined in the Contract Data are not defined in the Conditions of Contract but keep their defined meanings. Capital initials are used to identify defined terms.

**Bill of Quantities** means the priced and completed **Bill of Quantities** forming part of the Bid.

**Compensation Events** are those defined in Clause 41.

**Contract Completion Date** is the date of completion of Contractor's obligations under this Contract for the works as indicated in the Contract Data.

**Contract** is the contract between the Employer and the Contractor to execute, complete and maintain the Works. It consists of the documents listed in Sub Clause 2.2.

**Contract Data** defines the documents and other information which comprise the Contract, more specifically refers to Section 4 of the Document.

**Contractor** is a person or firm, whose Bid to carry out the Works has been accepted by the Employer.

**Contractor's Bid** is the completed Bidding document submitted by the Contractor to the Employer.

**Contract Price** is the price stated in the Letter of Acceptance for Sign Boards works.

**Days** are calendar days; **months** are calendar months.

**Defect** is any part of the Works not completed in accordance with the Contract.

**Defects Liability Period** is the period specified in the Contract Data and calculated from the works Completion Date. For this particular contract, Defects Liability Period is 18 months after the works Completion Date.

**Drawings** include calculations and other information provided.

**Employer** is the party who will employ the Contractor to carry out the Works or its authorized representative.

**Authorized representative** is the person (or any other competent person appointed and notified to the Contractor to act in replacement of the Employer) who is responsible for supervising the execution of the Works and administering the Contract.

**Equipment** is the Contractor's machinery and vehicles' brought, temporarily or otherwise, to the Site to construct the Works.

**Intervention Standards** is the level of the damage at which road assets need to be intervened and repaired.

**Letter of Acceptance** means the formal acceptance by the Employer of the Bid.

**Materials** are all supplies, including consumables, used by the contractor for incorporation in the Works.

**Milestone** is a specified date or duration by which specified works are to be completed.

**Permanent Works** means the permanent works to be executed in accordance with the Contract.

**Plant** is any integral part of the Works which is to have a mechanical, electrical, electronic or chemical or biological function.

**Rectification Standards** is the period of time given to repair the damage to the road asset.

**Sign Boards works Completion Date** is the actual date of completion of Sign boards installation works as certified by the Employer in accordance with Sub Clause 50.1.

**Road Asset Group** is clubbing of similar activities for road maintenance.

**Service Quality** specifies the condition of the road asset which gives a desirable level of service and comfort.

**Site** is the area defined as such in the Contract Data.

**Specification** means the Specifications of the Works included in the Contract and any modification or addition made or approved by the Employer, in writing.

**Start Date** is given in the Contract Data. It is the date when the Contractor shall commence execution of the Works. It does not necessarily coincide with any of the Site Possession Dates.

**Subcontractor** is a person or firm or corporate body who has a contract with the Contractor to carry out a part of the work in the Contract.

**Temporary Works** are works designed, constructed, installed, and removed by the Contractor which are needed for construction or installation or maintenance of the Works.

**Variation** is an instruction given by the Employer in writing which varies the Works.

**Works** means the Sign Boards works as stated in the Contract Data.

**Working Drawings** means all Drawings, calculations, samples, patterns, models, maintenance manuals and other technical information of a like nature submitted by the Contractor and approved by the Employer, for execution of the Works.

## 2. **Interpretation**

- 2.1. In interpreting these Conditions of Contract, singular also means plural, male also means female or neuter, and the other way around. Headings have no significance. Words have their normal meaning under the language of the Contract unless specifically defined. The Employer will provide instructions clarifying queries about the Contract.
- 2.2. The documents forming the Contract shall be interpreted in the following order of priority:
  - a) Agreement (if completed)
  - b) Letter of Acceptance
  - c) Contractor's Bid
  - d) Contract Data
  - e) Conditions of Contract
  - f) Specifications
  - g) Priced Bill of Quantities; and

h) Any other document forming part of the Contract.

3. **Language and Law**

3.1. The language of the Contract and the law governing the Contract are stated in the Contract Data.

4. **Engineer's Duties and Employer**

4.1. Deleted

4.2. Deleted.

4.3. Deleted

5. **Delegation**

5.1. Deleted.

6. **Communication**

6.1. Communication between parties of the Contract shall be effective only when it is in writing. A notice shall be effective only when it is delivered (in terms of Indian Contract Act).

7. **Subcontracting**

Whole or any part of Subcontracting of the work is not allowed

8. **Other Contractors**

8.1. The Contractor shall cooperate and share the Site with other Contractors, public authorities and the Employer and his representatives. The Contractor shall provide facilities and services for them related to the Work. The Employer may modify the Schedule of Other Contractors and shall notify the Contractor of any such modification.

9. **Personnel**

9.1. The Contractor shall employ the key personnel for the Construction works, named in the Details of Key Personnel as referred to in the Contract Data to carry out the functions of the positions stated in Annexures–1C and 1D of the Instructions to Bidders, Section 1 or other personnel approved by the Employer. The Employer will approve any proposed replacement of key personnel only if their qualifications, abilities, and experience are relevant to the nature of duties.

9.2. If the Employer asks the Contractor to remove a person who is a member of the Contractor's staff or his work force stating the reasons, the Contractor shall ensure that the person leaves the Site within seven days and has no further connection with the work in the Contract.

**10. Employer's and Contractor's Risks**

10.1. The Employer carries the risks which this Contract states are Employer's risks, and the Contractor carries the risks which this Contract states are Contractor's risks.

**11. Employer's Risks**

11.1. The Employer is responsible for the excepted risks which are in so far as they directly affect the execution of the Works in the Employer's country, the risks of war, hostilities, invasion, act of foreign enemies, rebellion, revolution, insurrection or military or usurped power, civil war, riot, commotion or disorder (unless restricted to the Contractor's employees), and contamination from any nuclear fuel or nuclear waste or radioactive toxic explosive.

**12. Contractor's Risks**

12.1. All risks of loss of or damage to physical property and of personal injury and death which arise during and in consequence of the performance of the Contract other than the excepted risks as at Sub Clause 11.1 are the responsibility of the Contractor.

**13. Insurance**

13.1. The Contractor shall provide, in the joint names of the Employer and the Contractor, insurance cover from any of the acceptable Insurance Companies in India, valid from the Start Date to the end of the Defects Liability cum Maintenance Period, including extended period, in the amounts and deductibles stated in the Contract Data.

13.2. Policies and certificates for insurance, from the acceptable Insurance Companies in India, shall be delivered by the Contractor to the Employer for the Employer's approval before the Start Date. All such insurance shall provide for compensation to be payable in Indian Rupees, along with the types and proportions required to rectify the loss or damage incurred.

13.3. If the Contractor does not provide any of the policies and certificates required, the Employer may affect the insurance which the Contractor should have provided and recover the premiums the Employer has paid, from payments otherwise due to the Contractor or, if no payment is due, the payment of the premiums shall be a debt due and if warranted, recovered from outstanding payments or from retention money.

13.4. Alterations to the terms of insurance shall not be made without the prior approval of the Employer, in writing.

13.5. The parties shall ensure that insurance is as per the applicable laws, and comply with all conditions of the insurance policies.

13.6. It shall be the responsibility of the Contractor to notify the insurance company of any change in the nature and extent of the Works and to ensure the adequacy of the insurance cover at all times during the period of the Contract or the extended period, if any.

**14. Contractor to Construct the Works and Works to be completed by Contract Completion Date**

14.1. The Contractor shall undertake the Works in accordance with the Contract as per instructions of the Employer.

14.2. The Contractor shall commence the Works on the Start Date and shall carry out the Works in accordance with the Program submitted by the Contractor, as updated with the consent of the Employer, and complete them by the Contract Completion Date stated in the Contract Data.

14.3. Deleted.

14.4. The works mentioned in Provisional Sum of BOQ, Section 6, Volume 2 shall be undertaken with the approval of the Employer

**15. Safety, Security and Protection of the Environment**

15.1. The Contractor shall, throughout the execution and completion of the Works, the remedying of any defects therein and during Defect Liability period:

- (a) have full regard for the safety of all persons entitled to be upon the Site and keep the Site so far as the same is under his control and the Works so far as the same are not completed or occupied by the Employer in an orderly state appropriate to the avoidance of danger to such persons;
- (b) provide and maintain at his own cost all lights, guards, fencing, warning signs and watching, when and where necessary or required by the Employer or by any duly constituted Employer, for the protection of the public or others; and
- (c) take all reasonable steps to protect the environment, on and off the Site, and to avoid damage or nuisance to persons or to property of the public or others resulting from pollution, noise or other causes arising as a consequence of his methods of operation.

The Contractor and his Subcontractors shall abide at all times by all existing enactments on environmental protection and rules made there under, regulations,

notifications and bye-laws of the State or Central Government, or local authorities and any other law, bye-law, regulations that may be passed or notification that may be issued in this respect in future by the State or Central Government or the local Employer. Some of the major laws that are applicable are given below:

- The Water (Prevention and Control of Pollution) Act, 1974.
- The Air (Prevention and Control of Pollution) Act, 1981.
- The Environment (Protection) Act, 1986.
- The Public Liability Insurance Act, 1991.

## 16. **Working Drawings**

16.1. Deleted

16.2. The Contractor shall submit Designs, Specifications and Drawings to the Employer who will approve these, if they complied with the specifications & Drawings.

## 17. **Approval by the Employer**

17.1. The Employer shall approve the Designs, Specifications and Drawings submitted by the Contractor

17.2. The Contractor shall obtain approval of other relevant authorities/agencies (if any like Railways Department etc.) for carrying out Works, where required.

17.3. The Employer's approval shall not relieve the Contractor of his obligations.

## 18. **Safety of Traffic**

18.1. The Contractor shall be responsible for the safety of all activities on the Site.

## 19. **Discoveries**

19.1. Anything of historical or other interest or of significant value unexpectedly discovered on the Site shall be property of the Employer. The Contractor shall notify the Employer of such discoveries and carry out the Employer's instructions for dealing with them.

## 20. **Possession of the Site**

20.1. The Employer shall give possession of the Site to the Contractor in accordance with the Contract Data. If possession of minimum 75% of the site is not given by the agreed date stated in the Contract Data, then the Sign Boards works Completion Date shall be postponed by the Employer as may be required for that particular part/stretch. However, this will not be applicable if sufficient work site is made available to the Contractor as and when required, for him to proceed ahead with progress of work and if available work fronts remain



unattached/unutilized. Please note that except time extension no other compensation shall be provided.

**21. Access to the Site**

21.1. The Contractor shall allow the Employer and any person authorized by them access to the Site, to any place where work in connection with the Contract is being carried out or is intended to be carried out and to any place where materials or plant are being manufactured / fabricated / assembled /stored for the Works.

21.2. Commencement of the Project

21.3. The Contractor shall commence the Works on Site within the period stated in the Contract Data after receipt by him of a Notice to this effect from the Employer, to be issued within 30 days after signing of the Agreement. Thereafter, the Contractor shall proceed with the Works with due expedition and without delay.

**The requirement to commence the Works at Site shall be fulfilled if:**

- a. A program has been submitted in accordance with Clause 25 of Conditions of Contract;
- b. The Contractor's authorized representative, with full supporting staff are in position at the Site;
- c. Equipment, Plant, materials and labour for the work programmed for execution in the first two months have been mobilized at the Site.

**22. Instructions**

22.1. The Contractor shall carry out all instructions of the Employer pertaining to the Works, which comply with the applicable laws where the Site is located.

**23. Disputes**

23.1. If either party believes that a decision taken by the Employer/Contractor was either outside the Contract or that the decision was wrongly taken, the objecting party may file notice of dispute to the other party stating that it is giving the notice pursuant to this Clause while stating clearly the basis for the dispute within 21 days of the notification of the decision.

23.2. The party receiving the dispute notice will consider it and reply in writing within 28 days of the receipt of the notice. If no reply is received or the reply is not acceptable to the other party, the affected party may refer the dispute for Arbitration to the Arbitral Tribunal.

**24. Procedure for Disputes – Arbitration**

24.1. The arbitration shall be conducted in accordance with the arbitration procedure stated in Clause 7 of the Special Conditions of Contract.



## **B: TIME CONTROL**

### **25. Program**

- 25.1. Within the time stated in the Contract Data, the Contractor shall submit to the Employer for consent, an updated Program for the awarded Works including Quality Control, Environment and Traffic Management Plans (*as per IRC:SP:55-2014 and Annexure -5B*) showing the general methods, arrangements, order, and timing for all the activities in the Works along with monthly cash flow forecast (Annexure 3A & 3B).
- 25.2. An update of the Program shall be a program showing the actual progress achieved on each activity and the effect of the progress achieved on the timing of the remaining work including any changes to the sequence of the activities.
- 25.3. If the Contractor does not submit an updated Program within this period as specified in the Contract Data, the Employer may withhold the amount stated in the Contract Data from the next payment certificate and continue to withhold this amount until the next payment after the date on which the overdue Program has been submitted. An updated Program is to show the effect of Variations and Compensation Events.
- 25.4. The Employer's consent of the Program shall not relieve the Contractor of his obligations.

### **26. Extension of the Sign boards works Completion Date**

- 26.1. The Employer shall extend the sign boards works Completion Date as stated in the Contract Data, if a Compensation Event occurs or a Variation is issued which makes it impossible for completion to be achieved by the sign boards works Completion Date, without the Contractor taking steps to accelerate the remaining work and which would cause the Contractor to incur additional cost.
- 26.2. The Employer shall decide whether and by how much to extend the Sign Boards works Completion Date, within 28 days of the Contractor asking the Employer for a decision upon the effect of a Compensation Event or Variation and submitting full supporting information. If the Contractor has failed to give early warning of a delay or has failed to cooperate in dealing with a delay, the delay by this failure shall not be considered in assessing the new Sign Boards works Completion Date.
- 26.3. Deleted.
- 26.4. Employer is fully empowered to grant extension to the Sign Boards works Completion Date.

26.5. Force Majeure will be applicable on back-to-back basis as per relevant clause of Concession Agreement between NHAI and Employer.

27. **Delays Ordered by the Employer**

27.1. The Employer may instruct the Contractor to delay the start or progress of any activity within the Works.

27.2. Deleted.

28. **Management Meetings**

28.1. Either the Employer or the Contractor may require the other to attend a management meeting/site visit. The business of a management meeting shall be to review the progress of work plans for remaining work and to deal with matters raised in accordance with the early warning procedure.

28.2. The Employer shall record the business of management meetings and shall provide copies of his record to those attending the meeting. The responsibility of the parties for actions to be taken is to be decided by the Employer either at the management meeting or after the management meeting and stated in writing to all those who attended the meeting. Failure to attend the management meetings/site visits shall attract penalties at the rate indicated in the Contract Data and in case of non-attendance of more than three such meetings/visits by the Contractor, then the same shall be construed as fundamental breach of the Contract in terms of Clause 54.

28.3. Maintenance Works Program and Review Meetings

- (a) Deleted.
- (b) Deleted

28.4. Monthly progress reports shall be prepared by the Contractor and submitted to the Employer in six hard copies and one soft copy. The first report shall cover the period upto the end of the first calendar month following the Start Date. Reports shall be submitted within 7 days for each month thereafter.

Each report shall include:

- (i) status of availability of site and problems related thereto, if any,
- (ii) status of mobilization and working of equipment & machinery,
- (iii) details of progress of work with charts and photographs,
- (iv) comparison of actual and planned progress, with details of any events or circumstances which may jeopardize the completion in accordance with the Contract, and the measures being (or to be) adopted to overcome delays,
- (v) status of procurement of material required for the work,
- (vi) list of Variations, notices given etc.,
- (vii) construction problems encountered, if any,
- (viii) copies of quality control documents, tests results and certificate of materials,

- (ix) safety statistics, including details of any hazardous incidents and activities, related to environmental aspects and public relations,
- (x) weather record during the month, day by day, and
- (xi) any other details/matters related to the Work.

**29. Early Warning**

- 29.1. The Contractor is to warn the Employer at the earliest opportunity of specific likely future events or circumstances that may adversely affect the quality of the Work, increase the Contract Price or delay the execution of the Works. The Employer may require the Contractor to provide an estimate of the expected effect of the future event or circumstance on the Contract Price and Contract Completion Date. The estimate is to be provided by the Contractor as soon as reasonably possible.
- 29.2. The Contractor shall cooperate with the Employer in making and considering proposals as to how the effect of such an event or circumstance can be avoided or reduced by anyone involved in the work and in carrying out any resulting instruction of the Employer.

## **C: QUALITY CONTROL**

### **30. Identifying Defects**

30.1. The Employer shall check the Contractor's work and notify the Contractor of any Defects that are found. The Employer may instruct the Contractor to search for a Defect and to uncover and test any work that the Employer considers may have a Defect. Such checking/instructions shall not absolve the Contractor of his responsibilities.

30.2. The Contractor shall permit the Site visits of the Employer's Technical Auditor/Independent Engineer/Lenders' Engineer to check the Contractor's work and notify the Employer and the Contractor of any Defects that are found. Such a check shall not absolve the Contractor's or the Employer's responsibility as defined in the Contract.

### **31. Tests/OEM warrantee**

31.1. 10 Year Warranty Certificate for reflectivity of Type XI signage boards to be submitted for satisfactory field performance of the finished sign with retro reflective sheeting as per the ASTM D4956 inclusive of the messages (Legends, Letters, Numerals, etc.), Images and borders by the respective Contractor/Supplier to the Engineer-In-Charge at the time of submission of bills. This Certificate shall be in the original letterhead of the Sheeting Principal Manufacturer (3M/ORAFOL).

31.2. Post Installation of signage boards, Retro-Reflectivity Test will be conducted on the Signages & Ra values at all angles of the Sign Boards should pass minimum Co-efficient values as mentioned in the IRC- 67 (2022) MORTH Guidelines in the front of the concern Authorities & Consultant.

31.3. The retro reflectivity test to be done free of cost every 2 years till the provided warranty period using Retro-Reflectometer and contractor should submit the test report.

### **32. Correction of Defects**

32.1. The Contractor shall undertake measures to rectify the defects in the Work identified by the Employer or any of the Employer's authorized representative at the earliest, but not later than the time period specified by the Employer.

32.2. In case of any failure in quality assurance and performance standards, the contractor shall rectify the defects at his own risk and cost within 15 days, failing which Employer may impose a penalty and can get the rectification done at the risk and cost of the contractor.

32.3. The Defect Liability Period shall be as given in the Contract Data. The Employer shall give notice to the Contractor of any defects before the end of the Defects Liability Period. The Defects Liability Period shall be extended for as long as defects remain to be corrected.

**33. Uncorrected Defects**

33.1. If the Contractor has not corrected a defect to the satisfaction of the Employer, within the time specified in the Employer's notice, the Employer will assess the cost of having the defect corrected, and the Contractor will pay this amount. In case of failure to pay, the same shall be deducted from any payment due to the Contractor/recovered from his Bank Guarantees under intimation to the Contractor.



## **D: COST CONTROL**

### **34. Bill of Quantities**

34.1. The Bill of Quantities shall contain items for supply, installation, testing and commissioning works to be executed by the Contractor.

34.2. The Bill of Quantities shall be the basis to calculate the payment for the above executed works. The Contractor is paid for the quantity of the work done at the rate in the Bill of Quantities for each item.

34.3. Deleted

### **35. Changes in the Quantities**

35.1. Deleted

35.2. The change in quantities/amounts due to increase/decrease in the scope of work, that is, Variation in Bill and in the Bill of Quantities, Section 6 of the Bid Document (Volume 2) shall be considered for additional payment as per rates defined in Bill of Quantities.

35.3. If requested by the Employer, the Contractor shall provide the Employer with a detailed cost breakdown of rate of any item in the Bill of Quantities.

35.4. *Barwa Adda Expressway Limited* is fully empowered to approve the variation of quantity and rates for extra item on the merit of the case.

### **36. Variations**

36.1. Item rates quoted for each BOQ item shall remain fixed irrespective of any Quantity Variation.

36.2. All Variations during implementation of the works, shall be included in updated Programs produced by the Contractor.

36.3. Deleted

### **37. Payments for Variations**

37.1. Deleted

37.2. If the event of variation is in terms of additional/extra item(s) or substitution of any item(s) in the BOQ with new item(s), then the rates for the items shall be decided on mutual consent.

37.3.

- (a) Deleted
  - (i) Deleted
  - (ii) Deleted
  - (iii) Deleted
  - (iv) Deleted
  - (v) Deleted

**38. Cash Flow Forecasts**

38.1. When the Program is updated, the Contractor shall provide the Employer with an updated cash flow forecast.

**39. Payment Certificates**

39.1. Sign Boards works

- (a) The Contractor is required to measure the work under the observation and control of the Employer. The Contractor shall submit to the Employer monthly statements of the estimated value of the work executed, less the cumulative amount certified previously and, applicable statutory deductions, outstanding advances supported with detailed measurements of the items of work executed, approved request for inspections (RFI) for the work done during the month, applicable rates and other relevant details, both in hard and soft form (in a Compact Disk of size acceptable to the Employer) along with an abstract statement, in accordance with the provisions of this Contract.
- (b) The Employer shall ascertain and determine by measurement the value of the work in accordance with the Contract. The Employer shall exclude any item in a previous certificate or reduce the proportion of any item previously certified in the light of later information.
- (c) The value of work executed shall comprise the value of quantities of the items in the Bill of Quantities.
- (d) The value of work executed shall include the valuation of Variations.
- (e) Items of the Works for which no rate or price has been provided in the priced BOQ will not be paid for by the Employer and shall be deemed to be covered by other rates and prices in the Contract.
- (f) The certification and payment methodology for supply & installation works shall be as given below:
  - (i) The contractor shall prepare and submit the running account bill as per the milestones for Procurement & Supply of sign boards materials and on monthly basis for Installation Part. The payment milestones shall be given in the contract data.
  - (ii) Employer shall evaluate the payment request in terms of the works executed as per milestones, and if the Employer finds the payment request in order, Employer shall recommend to Project management

consultant/ Lender's Independent Engineer for certification of the contractor's RA bill.

- (iii) 5% of Retention Amount shall be deducted from each RA Bill which shall be released on successful completion of Defect Liability Period of 18 months.
- (iv) The Contractor must submit invoices of material purchase for executed quantities with RA Bills. The RA Bills will not be processed further for release of payment in absence of the material invoices and test reports. Contractor shall also submit original copies relevant Manufacturer Test Certificate and warranty related authentic documents for material used in the work as per relevant Codal Provision at the time of supply of material at site.

### 39.2. Deleted

## 40. Delayed and Disputed Payments

40.1. Deleted

## 41. Compensation Events

41.1. Deleted

## 42. Tax

42.1. The rates quoted by the Contractor shall be deemed to be inclusive of GST and all other applicable taxes including duties/royalties/levies as may be levied by Central/State Governments and local bodies that the Contractor will have to pay for the performance of this Contract. The Employer will perform such duties in regard to the deduction of such taxes at source as per applicable law on the date of payment of the Contractor's bill.

## 43. Currencies

43.1. **All payments shall be made in Indian Rupees only.**

## 44. Changes in Cost and Legislation

### 44.1. Price Adjustment

**Deleted**

### 44.2. Other Changes in Cost

**Deleted**

**44.3. Adjustment Formulae**

Deleted

**44.4. Base, Current and Provisional Indices**

Deleted

**44.5. Limit of Price Adjustment**

Deleted

**45. Liquidated Damages and Penalty**

**45.1. Sign Boards works**

Liquidated damages shall be imposed at 0.25% of Contract Value per week of delay limited to 10% of the total Contract Value applicable to each milestone completion. However, these Liquidated damages shall be returned on successful completion of the subsequent milestones within scheduled completion date. In case of delay beyond the scheduled completion date, the liquidated damages imposed shall not be returned.

**46. Deleted**

**47. Advance Payment**

Deleted

**48. Performance Bank Guarantee (Securities)**

48.1. Contractor shall furnish a Performance Security to the Employer of a sum equivalent to 3% of Agreed Contract Value (Excluding GST) as security for due and faithful performance of its obligations, under and in accordance with the Agreement, during the Work completion Period which shall remain in force and effect till the end of 28 days from Defects Liability Period of 18 months.

**49. Cost of Maintenance**

49.1. Loss or damage to or defective works or materials during the execution of Works shall be remedied by the Contractor at the Contractor's cost to the satisfaction of the Employer.

## **E: FINISHING THE CONTRACT**

### **50. Completion**

50.1. The Contractor shall request the Employer to issue a certificate of completion of Sign boards works and the Employer shall do so upon deciding that the Sign Boards is completed.

50.2. No later than 30 days prior to the Contract Completion Date, the Contractor and the Employer shall conduct a condition survey of all the items mentioned in the Road Asset Groups and the items not confirming to the specified Intervention Standard shall be recorded.

Where items not meeting the specified Interventions Standard are identified, the Employer shall:

- (a) provide a written record of the condition survey to the Contractor within 14 days of the completion of the survey. The Employer's decision on the condition of any item of Road Asset Group shall be final.
- (b) direct the Contractor to rectify the deficiencies within the specified Rectification Standard / Period.

50.3. On satisfactory completion of Defect Liability Period, the Contractor shall request the Employer to issue a Certificate of Completion of the Contract. The Employer shall, issue such certificate subject to the Contractor satisfying all provisions under the Contract.

### **51. Taking Over**

#### **51.1. Taking over of the works & Sections**

The Works shall be taken over by the Employer when the Works have been completed in accordance with the Contract. The Contractor may apply by notice to the Employer for a Taking-Over Certificate within 14 days. The Employer shall, within 28 days after receiving the Contractor's application issue the Taking-Over Certificate to the Contractor/ reject the application, giving reasons and specifying the work required to be done by the Contractor. If Employer fails to take-over within 28 days of properly completed works, it is deemed to have been taken over.

#### **51.2. Taking over of the Part of the works**

No taking-over of part of the Works unless stated in Contract or agreed by both the parties.

#### **51.3. Interference with Tests on Completion**

If the Contractor is prevented, for more than 14 days, from carrying out the Tests for which the Employer is responsible, the Contractor shall carry out the Tests.

If Contractor suffers delay and incurs cost due to delay extension of time and contractor's claim will be applicable.

**52. Final Account**

52.1. In case of Sign Boards works, the Contractor shall supply to the Employer a detailed account of the total amount that the Contractor considers payable under the Contract within 60 days after the issue of certificate of completion of Sign Boards works by the Employer as per Sub Clause 50.1. The Employer shall certify any final payment that is due to the Contractor within 60 days of receiving the Contractor's account. If the Employer is not satisfied with the detailed account, then the Employer shall issue within 30 days thereto a schedule that states the scope of the corrections or additions that are necessary. If the Contractor fails to comply with the Employer's instructions within 15 days, Employer will certify as per the schedule of Corrections or addition sent to contractor and make payment to the Contractor within 45 days.

52.2. The Contractor shall submit his Final Statement of Account within 45 days of the Contract Completion Date and the Employer shall certify within 45 days and submit to the Employer any final payment that is due to the Contractor. Thereafter, the Employer shall make payment to the Contractor within 30 days. If the Employer is not satisfied with the detailed account, then the Employer shall issue within 30 days, thereto, a schedule that states the scope of the corrections or additions that are necessary. If the revised final account is still unsatisfactory after it has been resubmitted, the Employer shall decide on the amount payable to the Contractor and issue a payment certificate within 30 days of receiving the Contractor's revised final account.

**53. As Built Drawings and Maintenance Manuals**

Deleted

**54. Termination**

54.1. The Employer or the Contractor may terminate the Contract if the other party causes a fundamental breach of the Contract.

54.2. Fundamental breach of the Contract includes, but shall not be limited to the following:

- (a) the Contractor stops work for 28 days when no stoppage of work is shown on the current program and the stoppage has not been authorized by the Employer;
- (b) the Employer or the Contractor is made bankrupt or goes into liquidation, other than for purposes of reconstruction or amalgamation;
- (c) a payment for certified bills is not paid by the Employer to the Contractor within 60 days of the date of the Employer's certificate;
- (d) the Employer gives notice that failure to correct a particular Defect is a fundamental breach of the Contract and the Contractor fails to correct it within a reasonable period of time determined by the Employer;
- (e) Deleted;

- (f) the Contractor has defaulted in fulfilling his obligations under this Contract;
- (g) the Contractor has contravened Sub-Clause 9.2;
- (h) the Contractor does not adhere to the agreed works program as per Clause 25 and also fails to attend the management meetings (Clause 28);
- (i) the Contractor fails to carry out instructions of the Employer within a reasonable time determined by the Employer in accordance with the Sub Clauses 15.1, 22.1 and 45.1;
- (j) the Contractor has delayed the completion of the Works beyond the period for which the maximum amount of liquidated damages has become payable as defined in the Contract Data;
- (k) if the Contractor, in the judgment of the Employer has engaged in corrupt, fraudulent or coercive practices as defined in Sub Clause 34.1 (a) of ITB in competing for or in executing the Contract.
- (l) Deleted

54.3. When either party to the Contract gives notice of a breach of contract to the Employer for a cause other than those listed under Sub Clause 54.2, the Employer shall decide whether the breach is fundamental or not.

54.4. Notwithstanding the above, the Employer may terminate the Contract for convenience.

54.5. If the Contract is terminated, the Contractor shall stop work immediately, make the Site safe and secure and leave the Site as soon as reasonably possible.

## 55. **Payment upon Termination**

55.1. If the Contract is terminated because of a fundamental breach of the Contract by the Contractor, the Employer shall issue a certificate for the value of the work done less advance payments made up to the date of the issue of the certificate, less other recoveries due in terms of the Contract, less taxes due to be deducted at source as per applicable law and less the percentage to apply to the work not completed as indicated in the Contract Data. If the total amount due to the Employer exceeds any payment due to the Contractor, the difference shall be a debt payable to the Employer. For this purpose, retention money recovered shall stand forfeited in favor of the Employer without any restrictions or preconditions.

55.2. If the Contract is terminated at the Employer's convenience or because of a fundamental breach of the Contract by the Employer, the Employer shall issue a certificate for the value of the work done, the reasonable cost of removal of Equipment, repatriation of the Contractor's personnel employed solely on the Works, and the Contractor's costs of protecting and securing the Works and less advance payments received up to the date of the certificate, less other recoveries due in terms of the Contract and less taxes due to be deducted at source as per applicable law and the Employer shall pay.

**56. Property**

56.1. If the Contract is terminated because of Contractor's default, all materials on the Site, Plant, Equipment, Temporary works and the Works are deemed to be the property of the Employer, till completion of the work. The Employer shall make use of the available materials and equipment for completion of the Work.

**57. Release from Performance**

57.1. If the Contract is frustrated by the outbreak of war or by any other event entirely outside the control of either the Employer or the Contractor, the Employer shall certify that the Contract has been frustrated. The Contractor shall make the Site safe and stop work as quickly as possible after receiving this certificate and shall be paid for all Works carried out before receiving the certificate and for any work carried out afterwards to which commitment was made.

**58. Details to be Confidential.**

58.1. The Contractor shall treat the details of the Contract as private and confidential and shall not publish or disclose the same or any particulars thereof in any trade or technical paper or elsewhere without the previous consent in writing of the Employer. If any dispute arises causing the necessity of any publication or disclosure for the purpose of the Contract, the same shall be referred to the Employer whose determination shall be final.

**59. Life-saving Appliances and First-aid Equipment**

59.1. The Contractor shall provide and maintain upon the Works and the Site, sufficient, proper and efficient life-saving appliances and first-aid equipment, to the satisfaction of the Employer. The appliances and equipment shall be available for use at all times during the pendency of the Contract.



### SECTION: 3

## PART – II: SPECIAL CONDITIONS OF CONTRACT

### Table of Contents

	Page No		Page No
<b>A General Clauses</b>		<b>C General Maintenance Requirements</b>	
1 Labour	67	10 Road Roughness Survey	70
2 Statutory Clearances	67	11 Management of Spoil and Excess Road Making Material	70
3 Revision of Quality Control Plan	68	12 Underground Sewer Pipelines	70
4 Measuring/Monitoring Equipment	68	<b>D Evaluation of Service Quality Levels of Maintenance Works</b>	
5 Private Roadside Structures	68	13 Deleted	70
6 Private Entrances	68	14 Compliance by Contractor	70
7 Arbitration	68	<b>Annexure – 3A</b>	71
<b>B Maintenance Management System</b>		Contractor’s Work Program and Cash flow forecast	
8 Deleted	69	<b>Annexure – 3B</b>	72
9 Deleted	69	Monthly Cash Flow Forecast	

## **PART – II SPECIAL CONDITIONS OF THE CONTRACT (SCC)**

### **A: GENERAL**

#### **1. Labor**

- 1.1. The Contractor shall, unless otherwise provided in the Contract, make his own arrangements for the engagement of all staff and labour, local or other, and for their payment, housing, feeding and transport.
- 1.2. The Contractor shall, if required by the Employer, deliver to the Employer a return in detail, in such form and at such intervals as the Employer may prescribe, showing the staff and the numbers of the different classes of labour from time to time employed by the Contractor on the Site and such other information as the Employer may require.
- 1.3. During continuance of the Contract, the Contractor and his Sub-Contractors shall abide at all times by all existing labour enactments and rules made thereunder, regulations, notifications and bye laws of the State or Central Government or local Employer and any other labour law (including rules) that may be passed or notification that may be issued under any labour law in future either by the State or the Central Government or any competent Employer.
- 1.4. The Contractor shall keep the Employer indemnified in case any action is taken against the Employer by the competent Authority on account of contravention of any of the provisions of any Act or rules made thereunder, regulations or notifications including amendments. If the Employer is caused to pay or reimburse, such amounts as may be necessary to cause or observe, or for non-observance of the provisions stipulated in the notifications/bye laws/Acts/Rules/regulations including amendments, if any, on the part of the Contractor, the Employer shall have the right to deduct any money due to the Contractor. The Employer shall also have the right to recover from the Contractor any sum required or estimated to be required for making good the loss or damage suffered by the Employer.
- 1.5. The employees of the Contractor and the Sub-Contractor in no case shall be treated as the employees of the Employer at any point of time.

#### **2. Statutory Clearances**

- 2.1. List of clearances to be obtained by the Employer and the Contractor are given below. It may be noted that the list below may not be exhaustive and in case any additional clearances are required, the same shall be procured by the Contractor, unless otherwise specified in the Law / guidelines of statutory agencies.

(a) **Employer's Responsibility:**

- (i) Environmental clearance for the project, if any;
- (ii) Permission for shifting of utilities;
- (iii) Permission for cutting trees;
- (iv) Land acquisition;

(b) **Contractor's Responsibility:**

- (i) All police and traffic management related clearances at the work sites;
- (ii) Employing labour and other labour related clearances (ESI / Contract Labour / Health / PF etc.);
- (iii) Electrical connections and Water Supply;
- (iv) Employment of migrant labour;
- (v) Establishing and operating labour camps;
- (vi) Location of fuel storage tanks / containers etc.;
- (vii) Clearances for using / storing explosives;
- (viii) All clearances required from the Fire Department; and
- (ix) Any other clearances that are not specifically included in Employer's list and may be required according to prudent utility practices or instructed by Employer/as per Concession Agreement.

3. **Revision of Quality Control Plan**

3.1. The Employer shall instruct the Contractor to revise and/or resubmit his Quality Control Plan, if required before giving approval. The Contractor shall implement any required changes to improve the Quality Control Plan. The approval of the Employer shall not absolve the Contractor of his responsibilities and obligations under the Contract.

4. **Measuring / Monitoring Equipment**

4.1. The Contractor shall ensure properly calibrated and functional measuring/ monitoring equipment, to the satisfaction of the Employer, at all times during the Contract.

5. **Arbitration (Refer GCC Sub Clause 24.1)**

5.1. The procedure for arbitration shall be as follows:

- (a) In case of Dispute or difference arising between the Employer and the Contractor relating to any matter arising out of or connected with this agreement referred for arbitration, shall be settled in accordance with the Arbitration and Conciliation Act, 1996.
- (b) The Arbitral Tribunal shall consist of three Arbitrators, one each to be appointed by the Employer and the Contractor. The third Arbitrator shall be chosen by consensus by the two Arbitrators so appointed by the Parties and shall act as the Presiding Arbitrator. In case of failure of the two Arbitrators

appointed by the parties to reach upon a consensus within a period of 30 days from the appointment of the Arbitrators, then the Presiding Arbitrator shall be appointed by the Indian Roads Congress on the request of the Employer.

- (c) If one of the parties fails to appoint its Arbitrator in pursuance of Sub Clauses (a) and (b) within 30 days after receipt of the notice of the appointment of its Arbitrator by the other party, then the Indian Roads Congress shall appoint the Arbitrator on the request of the Employer. In case the Employer fails to do so within 30 days, the Contractor will approach the Indian Roads Congress for appointment of Arbitrator. A certified copy of the order of the Indian Roads Congress, making such an appointment shall be furnished to each of the parties.
- (d) Arbitration proceedings shall be held at Mumbai and the language of the arbitration proceedings and that of all documents and communications between the parties shall be English.
- (e) The decision of the majority of Arbitrators shall be final and binding upon both parties. The cost and expenses of Arbitration proceedings will be paid as determined by the Arbitral Tribunal and shared equally by both the parties.
- (f) Performance under the Contract shall continue during the arbitration proceedings and payments due to the Contractor by the Employer shall not be withheld, unless they are the subject matter of the arbitration proceedings.

## **B: MAINTENANCE MANAGEMENT SYSTEM**

6. **Deleted**

7. **Deleted**

## **C: GENERAL MAINTENANCE REQUIREMENTS**

8. **Maintenance Survey**

Deleted

9. **Management of Spoil and Excess Road Making Material**

Deleted

10. **Underground Sewer Pipelines**  
Deleted

**D: EVALUATION OF SERVICE QUALITY LEVELS FOR PAYMENT OF  
MONTHLY CERTIFICATE FOR MAINTENANCE WORKS**

11. **Deleted**
12. **Compliance by Contractor**  
Deleted

**CONTRACTOR’S WORKS PROGRAM AND CASH FLOW FORECAST**

Contractor shall cover the following:

1. Program of Supply & Installation, backed with material planning and deployment, duly supported with broad calculations as per Site handing over.
2. Critical Path Method and Schedule and/PERT or bar chart, with resource allocations based on Contractor’s work program.
3. Quality assurance procedures proposed to be adopted.
4. A concise method statement in narrative form covering all major activities.
5. Details of Contractor’s schedule of site takeover  
The Contractor shall include additional INFORMATION necessary to complement and accurately describe the proposed work program and possession of site schedule.



## **SECTION 4:**

### **CONTRACT DATA**



## CONTRACT DATA

Sr. No.	Item	Clause Reference of CC									
1	The Employer is : Barwa Adda Expressway Limited The IL&FS Financial Center, Plot C-22, G Block, Bandra Kurla Complex, Mumbai- 400051 Tel.: +91 022-26593693/022-26594804 E-mail: tender. itnl.projectbids@itnlindia.com Website: www.itnlindia.com Contact Person- Mr. Ravi Praveen Kumar/ Mr. Sachin Joshi	1.1 GCC									
2	The Employer is BAEL	1.1 GCC									
3	The project work is <b>“Supply &amp; Installation of Retro Reflective Signage &amp; Gantry boards at various locations between km 398.240 to km 521.120 in the States of Jharkhand and West Bengal.” (“Project”).</b>	1.1 GCC									
4	The Works consists of Supply & Installation of sign boards works as per Bill of Quantities enclosed at Volume 2 – Section 6	1.1 ITB									
5	The Start Date (Commencement Date) shall be within <b>7 days</b> from the date of issue of Letter of Award / signing of the Contract Agreement for the works whichever is earlier.	1.1 and 21.2 GCC									
6	The language of the Contract documents is English	3 GCC									
7	The law which applies to the Contract is the laws of Union of India	3 GCC									
8	The following documents are also part of the Contract in addition to documents mentioned in Sub Clause 2.2 of GCC: Details of Minimum Key Construction Plant and Equipment required to be mobilized by Contractor for the works (as per Annexures–1A)  Deleted	4.4 (a) of ITB  9 GCC									
9	Insurance requirements are as under:  <table style="width: 100%; border-collapse: collapse;"> <thead> <tr> <th style="text-align: left;">Sr. No.</th> <th style="text-align: left;">Description of Cause</th> <th style="text-align: left;">Minimum Cover of Insurance</th> </tr> </thead> <tbody> <tr> <td colspan="3"><i>During works</i></td> </tr> <tr> <td style="vertical-align: top;">i</td> <td>Contractor’s All Risk Policy covering loss or damage to Works, and Material for full replacement value including earthquake, terrorism, storm, tempest, flood, inundation cover &amp; defect liability</td> <td>Contract Price + 15% escalation</td> </tr> </tbody> </table>	Sr. No.	Description of Cause	Minimum Cover of Insurance	<i>During works</i>			i	Contractor’s All Risk Policy covering loss or damage to Works, and Material for full replacement value including earthquake, terrorism, storm, tempest, flood, inundation cover & defect liability	Contract Price + 15% escalation	13 GCC
Sr. No.	Description of Cause	Minimum Cover of Insurance									
<i>During works</i>											
i	Contractor’s All Risk Policy covering loss or damage to Works, and Material for full replacement value including earthquake, terrorism, storm, tempest, flood, inundation cover & defect liability	Contract Price + 15% escalation									

	<p>cover.</p> <p>ii Loss or damage to Property, other than (i) and (ii) above, in connection with the Contract ₹ 50 Lakh</p> <p>iii Personal injury or death insurance. Unlimited number of accidents. After each accident, Contractor will pay additional premium necessary to increase the limit make insurance valid for unlimited number of accidents always ₹ 5 Lacs per person per accident for unlimited number of accidents</p> <p>v Public Liability Policy</p> <p>i) For duration of the Project – ₹ 1 Crore ii) Any one accident – ₹ 0.50 Crore/accident</p> <p>vi Against liabilities for death or injury to any person or loss of or damage to any third-party property In accordance with statutory requirements, applicable in India.</p> <p>vii Advance Loss of Profit Policy Sum sufficient to cover anticipated loss</p> <p>viii Any other insurance cover In accordance with statutory requirements, applicable in India.</p> <p><b>Note:</b> For the above purpose “Roads” include: Main road with service roads, subways, culverts, toe wall, dividing median, crash barriers, electrical poles, separator, public toilets etc. and other infrastructure related to insured trade including sign boards and other property of the project along with electrical fittings, side separator, crash barrier, dividing median various culverts, Cat Eyes, Delineators, W-Beam Crash Barrier, Gantry Sign Boards, Single led Sign Boards, Double legged Sign Boards, Cantilever Sign Boards, Bollards, Road Marking, and other properties of insured.</p>	
10	<p>Contract Completion Date for:</p> <p>i. Sign Boards works: - <b>6 Months</b> from the Start Date of the Works</p> <p>(b) Defect Liability Period: - 18 Months</p>	<p>14 GCC</p>
11	The Site Possession shall be given within 3 days from Start Date	<p>20 GCC</p>
12	The period between Program Updates shall be 30 days	<p>25</p>

				GCC
13	The amount to be with-held for late submission of an updated Program shall be Rs 50,000/- each time			25 GCC
14	Penalty for not attending Management Meetings/ Site visits including Weekly Meetings: Rs 5000/- per incidence			28 GCC
15	The following are Compensation Events unless they are caused by the Contractor: (a) Deleted			41 GCC
16	The item rates to be quoted shall be inclusive of GST. The component of GST shall be released on submission of the GST paid challans and on receipt of payment from NHAI towards the same. The contractor shall be Responsible for the payment of Labor Cess to the concerned Department.			42.1 GCC
17	Changes in Cost and Legislation Deleted			44 GCC
18	Penalty and Liquidated Damages:			45 GCC
	<b>S. No.</b>	<b>Particulars</b>	<b>Penalty / Liquidated Damages</b>	
	1	Delay of work	Penalty shall be applicable @ <b>0.25% value of the Contract Price per week</b> of delay for non- completion of the work applicable to each milestone completion. However, these Liquidated damages shall be returned on successful completion of the subsequent milestones within scheduled completion date. In case of delay beyond the scheduled completion date, the liquidated damages imposed shall not be returned.	Maximum cumulative (total) penalty shall be applicable @10% of the Contract Price
20	Deleted			46 GCC
21	Deleted			47 GCC

22	Performance Bank Guarantee: - 3% of Agreed Contract Value (Excluding GST) to be submitted from an approved scheduled bank/ nationalized bank in approved format. The Performance Bond will be valid right through the contract and till the end of 28 days from defects liability period of 18 months. Form 7I in Section 7 of the Bidding Documents.	48 GCC
23	OEM warrantee period: 10 Year Warranty Certificate for reflectivity of Type XI signage boards to be submitted for satisfactory field performance of the finished sign with retro reflective sheeting as per the ASTM D4956 inclusive of the messages (Legends, Letters, Numerals, etc.), Images and borders by the respective Contractor/Supplier to the Engineer-In-Charge at the time of submission of bills. This Certificate shall be in the original letterhead of the Sheeting Principal Manufacturer (3M/ORAFOL).  Post Installation of signage boards, Retro-Reflectivity Test will be conducted on the Signages & Ra values at all angles of the Sign Boards should pass minimum Co-efficient values as mentioned in the IRC- 67 (2022) MORTH Guidelines in the front of the concern Authorities & Consultants.  The retro reflectivity test to be done free of cost every 2 years till the provided warranty period using Retro-Reflectometer and contractor should submit the test report	31 GCC
24	Defects Liability Period: 18 Months However, in case of any delay by the Authority for issuing a Final Completion Certificate to Employer due to incomplete or unsatisfactory work of contractor's scope, DLP shall be started after final completion certificate issued by the Authority to Employer.	32 GCC
23	The Works shall be taken over by the Employer when the Works have been completed in accordance with the Contract. The Contractor may apply by notice to the Employer for a Taking-Over Certificate within 14 days. The Employer shall, within 28 days after receiving the Contractor's application issue the Taking-Over Certificate to the Contractor/ reject the application, giving reasons and specifying the work required to be done by the Contractor. If Employer fails to take-over within 28 days of properly completed works, it is deemed to have been taken over.	51 GCC
24	Deleted	55.1 GCC
25	Deleted	125 of STS
26	Deleted	126 of STS
27	The Contractor shall solely be responsible for implementation of Traffic Management and Diversion during execution of awarded work as per IRC:SP:55-2014 "Guidelines on Traffic Management in Work Zones, other relevant IRC Codes, Clause 112 of Specifications for Road & Bridge Works (5th Revision) and as per Annexure -5B of RFB Volume I. Upon <b>Failing to</b>	Annexure -5B

	<i>adhere to implement Traffic Management, Diversion and Safety as per agreed &amp; defined norms the Employer shall have the right to impose deduction of 2% of amount from each Running Account Bill of the Contractor as penalty.</i>										
28	Contractor shall carry out all Quality Test / relevant Test as per relevant applicable MoRTH & IRC Specifications. All necessary testing / test certificate for material used / work executed shall be carried out / provided by the contractor to the full satisfaction of Employer/IE and Test Reports shall be submitted along with RA Bills.	31 GCC									
29	<p>The contractor shall prepare and submit the running account bill as per the milestones for supply &amp; Installation of sign boards. The payment milestones are as below:</p> <table border="1" data-bbox="344 741 1193 1339"> <thead> <tr> <th>Sr no</th> <th>Milestone to be achieved</th> <th>Invoice value/Payment to be made</th> </tr> </thead> <tbody> <tr> <td>I</td> <td>Procurement &amp; Supply of Sign boards, Steel for Gantry Structure</td> <td>60% payment of Contract value shall be released to the contractor against submission of E-way bill, delivery challans, etc &amp; verification for receipt of 100% materials at site by BAEL</td> </tr> <tr> <td>II</td> <td>Installation completion of signage boards and Gantry Structure.</td> <td>40% payment of contract value shall be released to the contractor against submission of PI &amp; verification of completion of works in all respects by BAEL</td> </tr> </tbody> </table> <p>60% payment of the Contract Amount shall be released to the contractor only upon delivery &amp; receipt of 100% materials at site &amp; verification of 100% materials received at site by BAEL</p> <p>The material receipt Challans need to be submitted by contractor for verification. The Material (100% procurement) shall be stored at the designated places in consultation with BAEL as directed by Engineer In Charge and shall be jointly recorded.</p> <p>The watch &amp; ward shall be the sole responsibility of the contractor. The representatives of BAEL and contractor shall jointly sign off on the material receipt and confirm 100% receipt of the material at site as per the requirement specified in the BoQ.</p> <p>The issue of material during construction shall be recorded each time material</p>	Sr no	Milestone to be achieved	Invoice value/Payment to be made	I	Procurement & Supply of Sign boards, Steel for Gantry Structure	60% payment of Contract value shall be released to the contractor against submission of E-way bill, delivery challans, etc & verification for receipt of 100% materials at site by BAEL	II	Installation completion of signage boards and Gantry Structure.	40% payment of contract value shall be released to the contractor against submission of PI & verification of completion of works in all respects by BAEL	39 GCC
Sr no	Milestone to be achieved	Invoice value/Payment to be made									
I	Procurement & Supply of Sign boards, Steel for Gantry Structure	60% payment of Contract value shall be released to the contractor against submission of E-way bill, delivery challans, etc & verification for receipt of 100% materials at site by BAEL									
II	Installation completion of signage boards and Gantry Structure.	40% payment of contract value shall be released to the contractor against submission of PI & verification of completion of works in all respects by BAEL									

<p>is issued from the store and jointly signed by BAEL and contractor's representative. The record has to be kept safe till successful completion of installation of sign boards.</p> <p>The Contractor shall follow all the procedures stipulated with NHAI for certification of the Running Account bills including the certification of IE &amp; NHAI representative. BAEL will assist the Contractor, however the responsibility of following the same solely lies with the Contractor. Work shall be executed under the supervision of Employer's representatives and payment shall be released to the contractor after certification from Employer, Project management consultant/ Lender's Independent Engineer.</p> <p>BAEL shall review / revise (if required) and then certify the same for release of payment. The certification shall be done by the Project Management Consultant, Lender's Independent Engineer and BAEL.</p> <p>For installation works, the Contractor must submit invoices for the Supply Part for executed quantities with RA Bills. The RA Bills will not be processed further for release of payment in absence of the material invoices and test reports. Contractor shall also submit relevant Manufacturer Test Certificate for material used in the work as per relevant Codal Provision at the time of supply of material at site.</p>	
--	--

## **SECTION 5: TECHNICAL SPECIFICATIONS & DESIGN**

## **SECTION: 5**

### **TECHNICAL SPECIFICATIONS & DESIGN**

#### **1. Technical Specifications Governing Design and Installation**

- 1.1. The Specifications contained herein shall be read in conjunction with the other Bidding Documents as specified in Section 1.
- 1.2. Wherever reference is made in the Contract to specific standards/codes to be met by the materials, plant, and other supplies to be furnished, and work performed or tested, the provisions of the latest current edition or revision of the relevant standards and codes shall apply, unless otherwise expressly stated in the Contract. Where such standards and codes are national, or relate to a particular country of region, other internationally recognized standards and codes specified will be accepted subject to the Employer's prior review and written approval.

#### **2. General Requirement**

The Specifications in accordance with which the entire work shall be constructed and maintained by the Contractor are as described hereunder:

The project / project facilities under this contract shall conform to the minimum design requirements set out in the Concession Agreement.

#### **3. DESIGN STANDARDS:**

Micro prismatic type retro reflective boards conforming to Type-XI ASTM D-4956, made of 2mm thick or 4mm thick Aluminium /ACP panel board as per IRC 67-22. The front side is to be covered with micro prismatic retro reflective sheeting conforming to Type XI ASTM D-4956 (supported with Indian test report for reflective sheeting by the government recognized laboratory in India for all the approved Traffic Colors as per the IRC Guidelines) with necessary back frame and post. All the texts, borders & symbols shall be digitally printed using technology printers recommended by sheeting Manufacturer or use the sign manufacturing method approved by IRC 67-2022. Finished signs shall have an Ultraviolet (UV) protective clear overlay applied to the entire face of the sign supplied by the reflective sheeting manufacturer. Overlay shall be part of a matched component system as recommended by the retro reflective sheeting manufacturer (3M/ORAFOL). Approved Digital printing as per new IRC 67-2022.

**Annexure – 5A**  
(Refer Sub Clause 111.13 of STS)



## ENVIRONMENTAL MONITORING PLAN

Sl.#	Environmental Issue	Description
1	Ambient Air Quality	<b>Installation Phase</b> <ul style="list-style-type: none"><li>• Ambient air quality monitoring for 24 hours twice in a week during summer, winter and post monsoon seasons near residential areas in each of the contract packages, where construction activities are undertaken for parameters like SPM, SO<sub>2</sub>, NO<sub>x</sub>, CO &amp; HC. In the event of violation of 24 hourly average Indian standard for residential areas, construction activities should be restricted from 6 am to 6 pm.</li></ul>
2	Noise Quality	<b>Installation Phase</b> <ul style="list-style-type: none"><li>• L<sub>eq day</sub> and L<sub>eq night</sub> to be monitored on monthly basis (other than for monsoon months) during construction phase near residential areas in each of the contract packages. In case of violations, construction activities are to be scheduled in such a way that the resultant noise levels are adhered to as per the standards.</li></ul>
3	Water Quality	<b>Installation Phase</b> <ul style="list-style-type: none"><li>• Monitoring of at least 4 grab samples of surface water and 2 grab samples of groundwater for physical, chemical and biological parameters – once during each season including monsoon season.</li></ul>
4	Soil Quality	<b>Installation Phase</b> <ul style="list-style-type: none"><li>• Monitoring of at least 1 grab sample of soil from each of the contract packages once during a season (other than monsoon season). The samples should be picked up from 60-70 m distance from centerline in the areas where construction activities are undertaken. The samples should be analyzed for heavy metals and oil &amp; grease.</li></ul>

To implement the EMP, an Environmental Management Cell (EMC) should be constituted before start of the Sign Boards work. EMC will undertake environmental monitoring and audits during construction and operation phases of the project and will check that environmental management measures are satisfactorily implemented with appropriate environmental performance. Specialized training should be imparted to construction Employers, contractors, staff and workers for effective implementation of the suggested EMP.

## **TRAFFIC SAFETY AND CONTROL**

### **1. Description**

The Contractor shall solely be responsible for implementation of Traffic Management and Diversion during execution of awarded work as per IRC:SP:55-2014 “Guidelines on Traffic Management in Work Zones, other relevant IRC Codes, Clause 112 of Specifications for Road & Bridge Works (5<sup>th</sup> Revision) and as per details provided herein.

These specifications describe the traffic management and safety measures to be taken by the Contractor throughout the Sign Boards works period for ensuring the safe and convenient passage of public traffic through the project road on one hand and safety of the project workers on the other. It shall be understood that the Contractor is solely responsible for all the traffic management and safety measures which should be got approved by the Employer prior to taking up any Sign Boards work on the project.

Any Sign Boards work on or near a public traveled way will pose a set of new situations, which may include diversion of road users on to unfamiliar paths, exposure of road users to moving construction equipment and workers, stacking of light fixtures/materials to cause reduction in the space available for public traffic, inadequate space for maneuvering, etc. which may pose several surprises. These may cause to develop hazardous situations in case adequate advance precautions in the form of notification, traffic etc. is not taken. Within the construction area itself, the workers may be handling materials like steel reinforcement/ Bar bending machine and moving road construction equipment which may prove to be a cause of serious accident if adequate precaution and safety measures are not taken. Thus, the guiding principles on which the Contractor shall base the traffic management and safety measures will include:

- i) advance warning of road users about the road situation including diversion ahead.
- ii) providing clear and safe demarcated channels for guiding the public traffic.
- iii) providing necessary traffic warning/ guiding devices such as signs, safety cones, pavement markings, red lights, reflecting studs/tapes, etc.
- iv) barricading construction area with CGI sheets so that public traffic steer clear of these and do not come into conflict with construction activities.
- v) providing the project workers with necessary safety gears such as gum boots, luminous yellow jackets, crash helmets etc. as appropriate.
- vi) taking all other necessary measures so that safety is ensured during all hours of day and night.

## 2. Traffic Management and Safety

Any construction activity on the project will pose a hazardous situation to the road users. For least disturbance to safe passage of public traffic appropriate traffic management and safety measures should be adopted throughout the construction period. In this regard, the construction zone in which conflict from safety angle may arise between the road users on one hand and the construction activities on the other shall be divided into 4 sub zones, and safety measures to be adopted therefore shall be as described hereunder:

a) Advance Warning Zone

This warning sub-zone is meant to inform, alert and prepare the approaching driver well in advance by providing information regarding the distance and extent/type of hazard ahead so that he is able to reduce the speed and be in readiness to carry out the necessary manoeuvres as he meets with the changed situation. For the operating speeds on the project road, length of this sub-zone shall be 100 mtr and 500 m, in plain and hilly terrain respectively. Information in this sub-zone will be conveyed through a series of traffic signs, which will include “Men at Work” and the speed reduction signs at the start and middle of this sub-zone.

b) Transition Sub-Zone

This sub-zone is the area in which the traffic is steered and guided into and out of the diverted path around the work sub-zone. This is the most crucial sub-zone from safety angle as vehicles have to be guided on to the diverted path, and most of the movements will be of turning type. The elements for designing this sub-zone are speed of the vehicles, extent of lateral shift and elevation difference between the normal and the diverted paths. The essential safety measures shall include delineation of the travel path and prevention of wayward movements of vehicles by means of barricades, channelizers, red cones, and red lamps during hours of darkness etc., as appropriate.

In the design of this sub-zone adequate attention shall be paid for providing necessary turning radius of the curves, grade to permit for safe passage of animal driven vehicles, drainage and dust-proofing. Where necessary traffic control shall be effected through manual flagging and by battery operated traffic lights during hours of darkness. Where vehicles have to wait, the waiting area shall be demarcated by stop lines.

Length of the sub-zone will generally be between 50 and 100 m.

c) Work Sub-Zone

This is to the area where construction activity takes place, and the main concern relates to safety of workers are also prevention of public traffic from entering the

work area. In this sub-zone, path of traffic shall be clearly delineated to avoid intrusion of public traffic moving on to the work area or construction equipment moving on to the public traffic. It shall be ensured that adequate distance is available between 2 consecutive work zones (2 Km. on urban section and 5-10 km. in rural sections) so that vehicles get sufficient breather space for overtaking slow vehicles, lane adjustment etc. Traffic across this sub-zone shall be guided through with the help of various traffic control devices, such as signs, delineation of travel path by cones/drums, barricades, luminous tapes etc. as appropriate.

d) Termination Sub-Zone

The sub-zone is intended to inform the road users of the end of the construction zone. This shall be effected through suitable informatory sign boards.

The standard on “Safety During Construction” may be referred for compliance.

### 3. Traffic Control Devices

Traffic control devices in the construction zones perform the crucial task of warning, informing and alerting drivers apart from guiding the vehicle movements so that the drivers of the vehicles as well as the workers on site are not faced with situations posing surprise/hazard, and safe passage to traffic is affected.

The primary traffic control devices used in work sub-zone are signs, delineators, barricades, cones, pylons, pavement marking, flashing lights etc. They shall be such that they are easily understood without any confusion, are clearly visible during day and night, conform to the prevailing speed in immediate vicinity, stable against sudden adverse weather conditions and are easy in installation, renewal and maintenance. Broad details of the different devices are hereunder:

a) Signs

The construction signs fall into 3 major categories namely, regulatory signs, warning signs and guide or informatory sign as defined and detailed in IRC:67-2012, Code of Practice for Road Signs (Third Revision). These signs shall be placed on the left-hand side of the travel path.

The common Regulatory signs used in the construction zones are “No Entry”, “Road Closed”, “Speed Limit” etc. These shall be used in consultation with the local police and / or authorities.

The warning signs to alert the drivers of the possible danger ahead in the construction zones are “Lane Closed”, “Diversion to other carriageway”, “Divided carriageway Starts”, “Divided carriageway End”, “Two-way Traffic” etc. It will be advisable to explain the signs with the help of a rectangular definition plate of

size of appropriate to the size of warning triangle and placed 0.15 m below, from the bottom of the triangle.

Guide signs in construction zones shall different background colour than the normal informatory signs of IRC:67-2012, These signs shall have black messages and arrows on yellow (Traffic Yellow of IS : 5-1978) background. The guide signs to e commonly used are “Diversion “Road Ahead Closed”, “Sharp Deviation of Rout” etc.

The commonly used temporary signs during construction are depicted in the drawings. These should preferably be of reflectorized type to be visible during hours of darkness.

b) Delineators

Delineators are channelizing devices such as cones, traffic cylinders, tapes, drums etc. which are placed in or adjacent to the roadway to guide the driver along a safe path and to control the flow of traffic. These shall normally be retro-refelected for night visibility. IRC: 79-2019 (Recommended Practice for Road Delineators – *First Revision*) gives details of some of the delineators. The types of delineators commonly used are traffic cones, drums and barricades.

c) Traffic Cones

Traffic cones shall normally be 0.5 m to 0.75 m high and 0.3 m to 0.4 m diameter or in square shape at the base. These shall be made of plastic or rubber with retro reflectorised red and white band and have suitable anchoring so that they are not easily blown over or displaced. The cones shall be placed close enough together (spacing 3-9m) to give an impression of the continuity. Larger sized cones shall be used for high speeds or where more conspicuous guidance is required.

d) Empty Metal / Bitumen / Emulsion Drums

Empty bitumen drums can be used as channelizing device since they are highly visible, give the appearance of being formidable objects, thereby commanding the respect of the drivers. These drums can also be of plastic which are lighter, easy to transport and store. As delineators, these drums shall be painted in circumferential strips 0.10 m to 0.15 wide, alternatively in black and white colours.

e) Barricades

When ever the traffic has to be restricted from entering the work areas such as excavations or material storage sites so that hazardous locations are barred for public and protection to workers is provided, or there is need for separation the two way traffic, barricades shall be used. The barricades may be of portable or fixed type and can be made of wooden planks, metal or other suitable material. The horizontal component facing the traffic shall be made of 0.30 m wide wooden planks joined together and painted in alternate yellow and white strips of 0.15 m

width and sloping down at an angle of 45° in the direction of traffic. Suitable support or ballasting shall be provided so that they do not over turn or are not blown away in strong winds. In case of fixed type barricades, a gate or moveable section shall be separately provided to allow the movement of the construction/supervision vehicles.

f) Flagmen

In large construction sites, flagmen with flags and sign paddles shall be effectively used to guide the safe movements. The flags for signaling shall be 0.60m x 0.60m size made of good red cloth and securely fastened to a staff of approximately 1 meter in length. The sign paddles shall conform to IRC:67-2012 and provided with a rigid handle.

For one-way operation at a time hours of darkness, battery operated red/green lights shall be used at either end of the affected section.

#### 4. **Safety and Management Practices**

Measures for providing safe movement of traffic in some of the most commonly occurring work-zones on highways shall be as follows:

a) Detour on Temporary Diversion

In certain situations during the project construction period it may become necessary to pass the traffic on temporary diversion constructed parallel to highway.

A temporary diversion road shall basically satisfy the following requirements

- ❖ It shall have smooth horizontal and vertical profile for easy negotiation by vehicles.
- ❖ It shall not get overtopped by flood or drainage discharge under any circumstances.
- ❖ It shall have adequate capacity to cater for the diverted traffic
- ❖ It shall be dust free and shall ensure clear visibility at all times of the day and night. Pavement and riding surface for the diversion will depend on the duration over which the diversion will be used, and shall be as directed by the Employer.
- ❖ It shall be provided with the required safety standards and specifications.

The warning for the construction ahead shall be provided by the sign “Men at Work” about 1 Km. in advance of the work zone. In addition a supplementary plate indication “Diversion 1Km. Ahead” and a sign “Road closed Ahead” shall be placed. It shall be followed by “Compulsory Turn right/left sign”. The “Detour” and sharp deviation” sign shall be used to guide the traffic on to the diversion. Hazard markers shall be placed where the railings for the cross drainage structures on the diversion start.

b) Switch over of traffic from widened section and vice-versa

In the course of construction there may be situations in which the traffic passing through the full width road would have to pass on and merge with narrowed diverted section and vice-versa. For such cases, apart from “Men At Work” signs with distance plate in the advance warning zone, the signs indicating “Road Narrowing” or “Road widening” as appropriate shall be installed.

**5. Precautions for Safety**

The following general precautions shall apply to all the work sites.

a) General Measures

- i) All the sign and delineators shall be maintained in clean and brightly painted conditions at all times.
- ii) Adequate lighting arrangements shall be made for proper visibility during night travel through the work area.
- iii) Adequate arrangements for frequent sprinkling of water shall be made to keep the area dust free.

b) For Safety of Workmen

- i) Workmen shall be trained in use of tools and plant.
- ii) First –aids kits shall be provided
- iii) Workers required on site during night hours shall be provided with fluorescent jackets with reflective tapes.

c) For Safety of Road User

- i) As far as possible, the material, equipment and machinery shall be installed/parked in places sufficient away from the berms in the available road land. Only in avoidable cases the same is allowed near the edge of berms.
- ii) Machinery shall be parked at appropriate places away from the path of public traffic, and shall be provided with red flags and red lights.
- iii) Only minimum quantity of material required for the construction operations shall be collected at site near the public traveled way.

**6. Safety Audit**

Safety audit shall be conducted periodically on the safety measures adopted during the constructions operations. The main aspects to be covered shall include:

- a) Machinery
- b) Temporary works
- c) Equipment & Vehicles
- d) Material storage and handling
- e) Construction procedures
- f) Environment

- g) Site safety guidelines
- h) Miscellaneous services

The contractor shall constitute special teams from his staff for the above audit and shall take appropriate corrective measures to the directions of the Employer.



### Single Side



1100 mm  
800 mm



<p><b>Darjeeling</b> দার্জিলিং দার্জিলিং</p>	<p>←</p> <p><b>513</b> km</p>	<p><b>Budbud</b> বুদবুদ বুদবুদ</p>	<p>↑</p> <p><b>14</b> km</p>	<p><b>Burdwan</b> বর্ধমান বর্ধমান</p>	<p>↑</p> <p><b>53</b> km</p>	<p>BAEL</p> <p><i>In Centre</i></p>
--	-----------------------------------	--	----------------------------------	---	----------------------------------	-------------------------------------

### Single Side

1100 mm  
800 mm

<p><b>Darjeeling</b> দার্জিলিং দার্জিলিং</p>	<p>←</p> <p><b>514</b> km</p>	<p><b>Arjan Singh Airforce Base</b> অর্জন সিংহ বায়ু সেনা অর্জন সিং বায়ুসেনাবেশ</p>	<p>↑</p> <p><b>05</b> km</p>	<p><b>Durgapur</b> দুর্গাপুর দুর্গাপুর</p>	<p>↑</p> <p><b>20</b> km</p>	<p>BAEL</p> <p><i>In Centre</i></p>
--	-----------------------------------	--	----------------------------------	--	----------------------------------	-------------------------------------

Board Size : 13.42 mtr X 2.1 mtr

Because Design speed = 81-100km/hr hence  
 x = 250 mm  
 X = 350 mm (1.4 of "x")



CLIENT:



NATIONAL HIGHWAYS  
AUTHORITY OF INDIA

PROJECT:

Six-laning of Barwa-Adda-Panagarh  
Section of NH-2 from km 398.240 to  
km 521.120 including Panagarh Bypass  
in States of Jharkhand and West Bengal  
under NHDP Phase V on Toll on  
DBFOT Pattern

INDEPENDENT ENGINEER:



S.A. Infrastructure Pvt. Ltd.  
101-102 CS-1, Gayan Khand-II  
Indirampuram, Ghaziebad - 201014

CONCESSIONAIRE :

Barwa Adda Expressway Limited

DESIGN BY :

IL&FS Transportation

IL&FS Transportation Networks Limited

FOR SUBMISSION

FROM :



Seven Dawn Solutions Pvt Ltd.  
Kanke Road, Ranchi - 834008  
Mob. 7739677770

TITLE :

ELEVATION DRAWING  
OF ROAD SIGNS

DRG. NO. : 7Dawn/BAEL/EDRS/01  
Date : 24/5/2017

REVISION :



*Revised*

CLIENT:



**NATIONAL HIGHWAYS  
AUTHORITY OF INDIA**

PROJECT:

Six-laning of Barwa-Adda-Panagarh  
Section of NH-2 from km 398.240 to  
km 521.120 including Panagarh Bypass  
in States of Jharkhand and West Bengal  
under NHDP Phase V on Toll on  
DBFOT Pattern

INDEPENDENT ENGINEER:



**S.A. Infrastructure Pvt. Ltd.**  
101-102 CS-1, Gayan Khand-II  
Indrapuram, Ghaziabad - 201014

CONCESSIONAIRE :

**Barwa Adda Expressway Limited**

DESIGN BY :



**IL&FS Transportation**

IL&FS Transportation Networks Limited

**FOR SUBMISSION**

FROM :



**Seven Dawn Solutions Pvt Ltd.**  
Kanke Road, Ranchi - 834008  
Mob: 7739677770

TITLE :

**ELEVATION DRAWING  
OF ROAD SIGNS**

DRG. NO. : 7Dawn/BAEL/EDRS/01

Date : 24/5/2017

REVISION :

	<b>Durgapur</b> दुर्गापुर দুর্গাপুর	↑ 24 km	<b>Bankura</b> बांकुड़ा বাঁকুড়া	↑ 71 km	<b>Darjeeling</b> दार्जीलिंग দার্জিলিং	↑ 519 km	<b>NH 2</b>	<b>WELCOME TO</b> <b>BARWA ADDA EXPRESSWAY LIMITED</b> (BARWA ADDA-PANAGARH SECTION NH-2 FROM KM 398.240 TO 521.120)	
---	---	---------------	--	---------------	--	----------------	-------------	--	---

	<b>Burdwan</b> बर्धमान বর্ধমান	↑ 47 km	<b>Kolkata</b> कोलकाता কলকাতা	↑ 157 km	<b>Kharagpur</b> खड़गपुर খড়গপুর	↑ 256 km	<b>NH 2</b>	<b>THANK YOU FOR VISITING</b> <b>BARWA ADDA EXPRESSWAY LIMITED</b> (BARWA ADDA-PANAGARH SECTION NH-2 FROM KM 398.240 TO 521.120)	
---	--------------------------------------	---------------	-------------------------------------	----------------	--	----------------	-------------	--	---

Board Size : 31.72 mtr X 2.1 mtr

Because Design speed = 101-110km/hr hence  
 x = 280 mm  
 X = 392 mm (1.4 of "x")

*Signature*  

CLIENT:  
 NATIONAL HIGHWAYS  
 AUTHORITY OF INDIA

PROJECT:  
 Six-laning of Barwa-Adda-Panagarh  
 Section of NH-2 from km 398.240 to  
 km 521.120 including Panagarh Bypass  
 in States of Jharkhand and West Bengal  
 under NHDP Phase V on Toll on  
 DBFOT Pattern

INDEPENDENT ENGINEER:  
 S.A. Infrastructure Pvt. Ltd.  
 101-102 CS-1, Gayan Khand-II  
 Indirampuram, Ghaziabad - 201014

CONCESSIONAIRE :  
**Barwa Adda Expressway Limited**

DESIGN BY :  
 Transportation  
 IL&FS Transportation Networks Limited

FOR SUBMISSION

FROM :  
 Seven Dawn Solutions Pvt Ltd.  
 Kanke Road, Ranchi - 834008  
 Mob: 7739677770

TITLE :  
**ELEVATION DRAWING  
 OF ROAD SIGNS**

DRG. NO. : 7Dawn/BAEL/EDRS/01  
 Date : 24/5/2017  
 REVISION :



*Signature*

CLIENT:  

**NATIONAL HIGHWAYS  
 AUTHORITY OF INDIA**

PROJECT:  
 Six-laning of Barwa-Adda-Panagarh  
 Section of NH-2 from km 398.240 to  
 km 521.120 including Panagarh Bypass  
 in States of Jharkhand and West Bengal  
 under NHDP Phase V on Toll on  
 DBFOT Pattern

INDEPENDENT ENGINEER:  

**S.A. Infrastructure Pvt. Ltd.**  
 101-102 CS-1, Gayan Khand-II  
 Indrapuram, Ghaziabad - 201014

CONCESSIONAIRE :  
**Barwa Adda Expressway Limited**

DESIGN BY :  

**IL&FS Transportation**  
 IL&FS Transportation Networks Limited

**FOR SUBMISSION**

FROM :  

**7Dawn**  
 Seven Dawn Solutions Pvt Ltd.  
 Kanke Road, Ranchi - 834008  
 Mob. 7739677770

TITLE :  
**ELEVATION DRAWING  
 OF ROAD SIGNS**

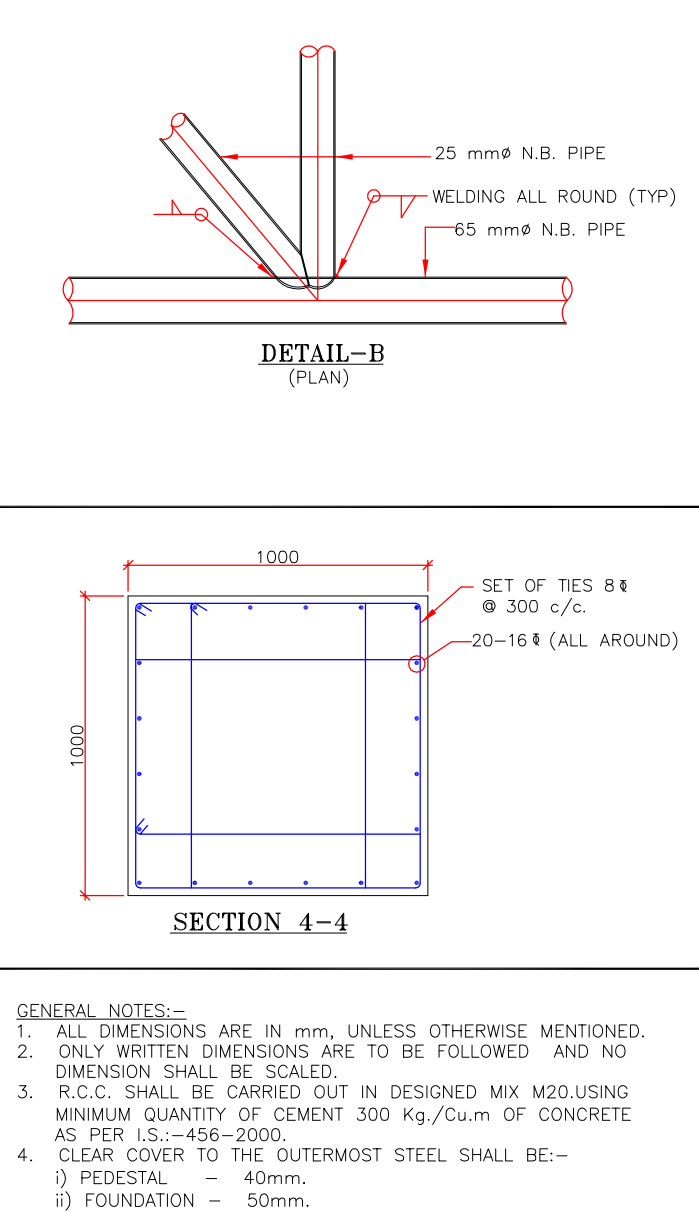
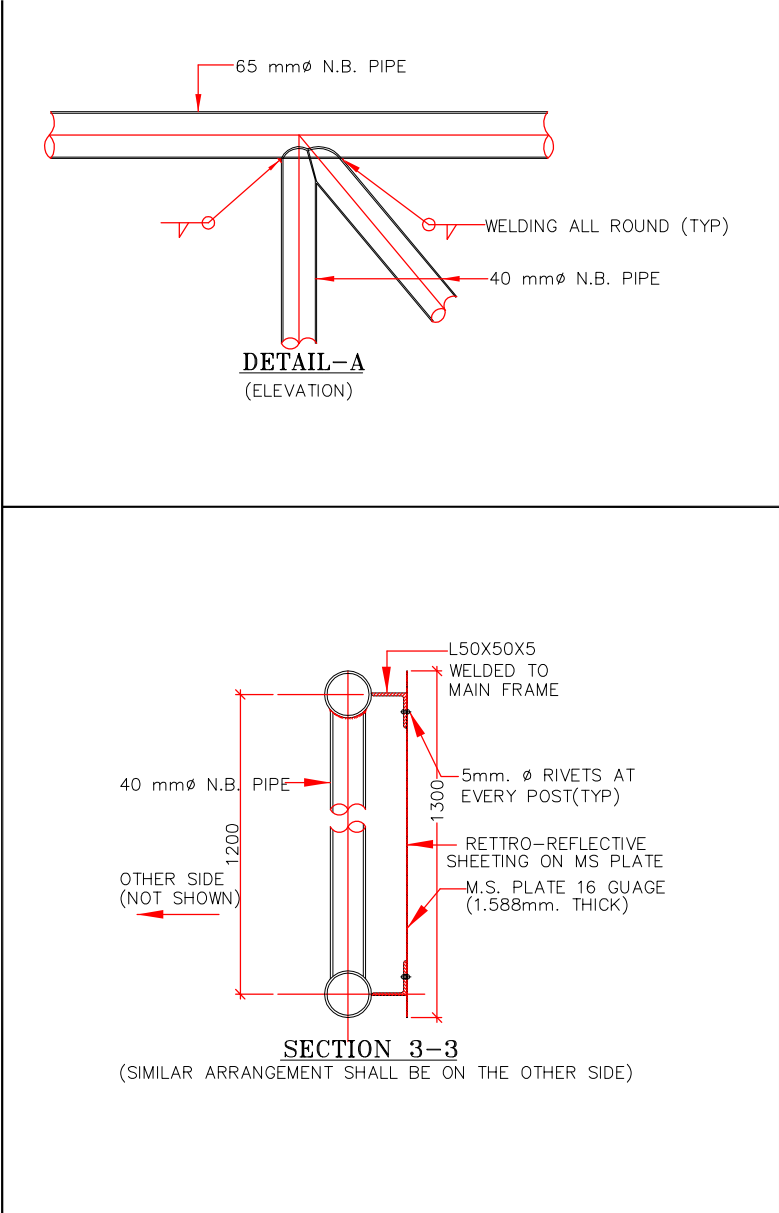
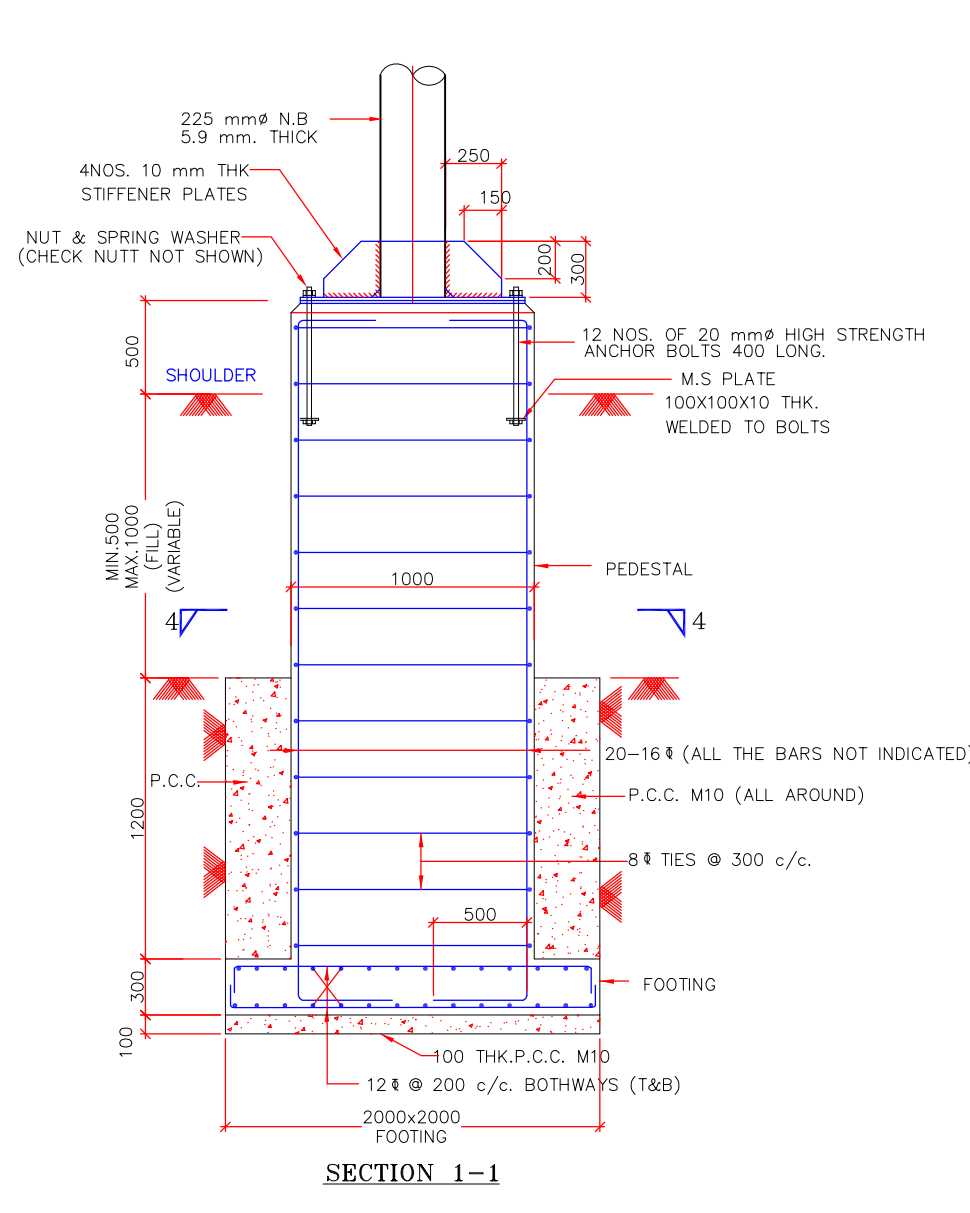
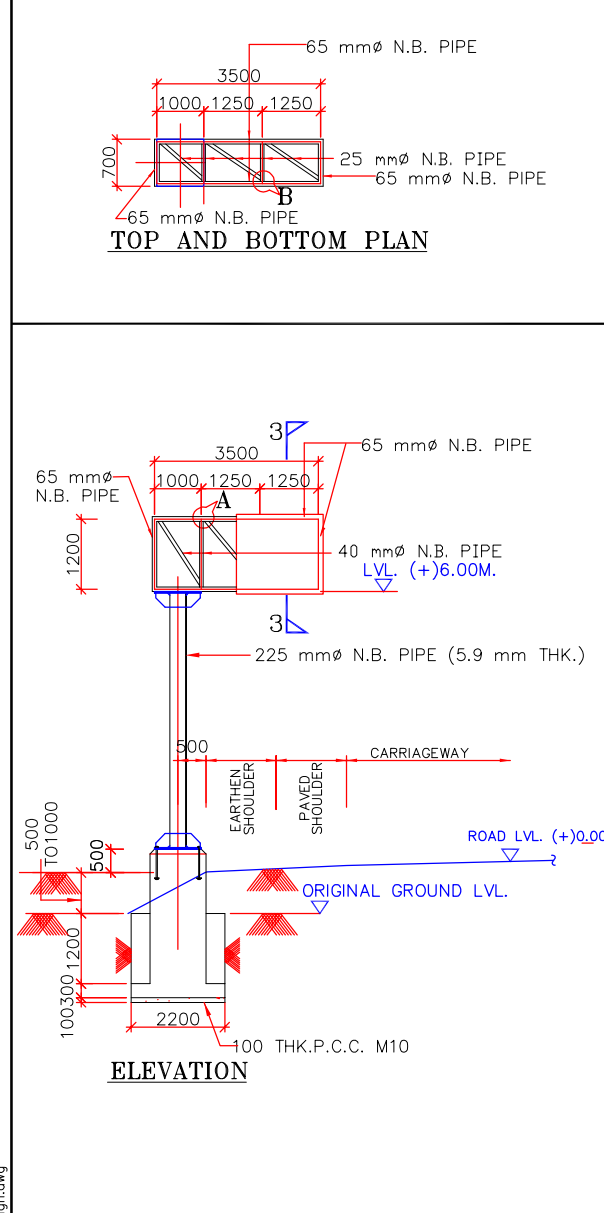
DRG. NO. : 7Dawn/BAEL/EDRS/01  
 Date : 24/05/2017  
 REVISION :

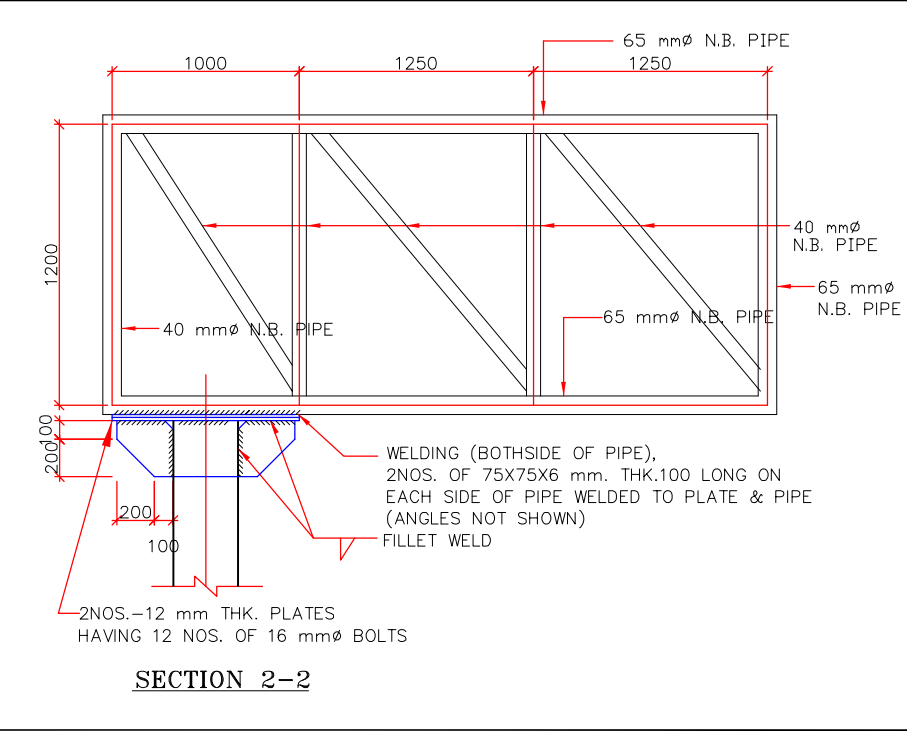
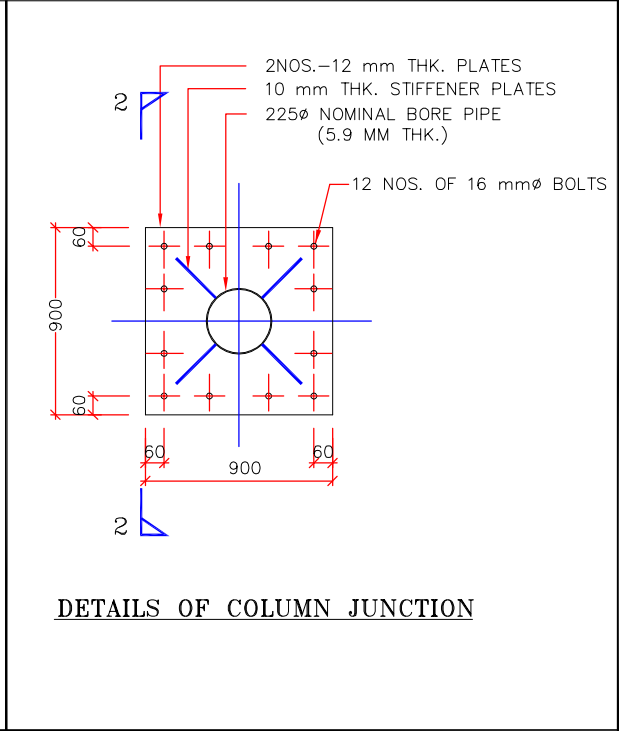
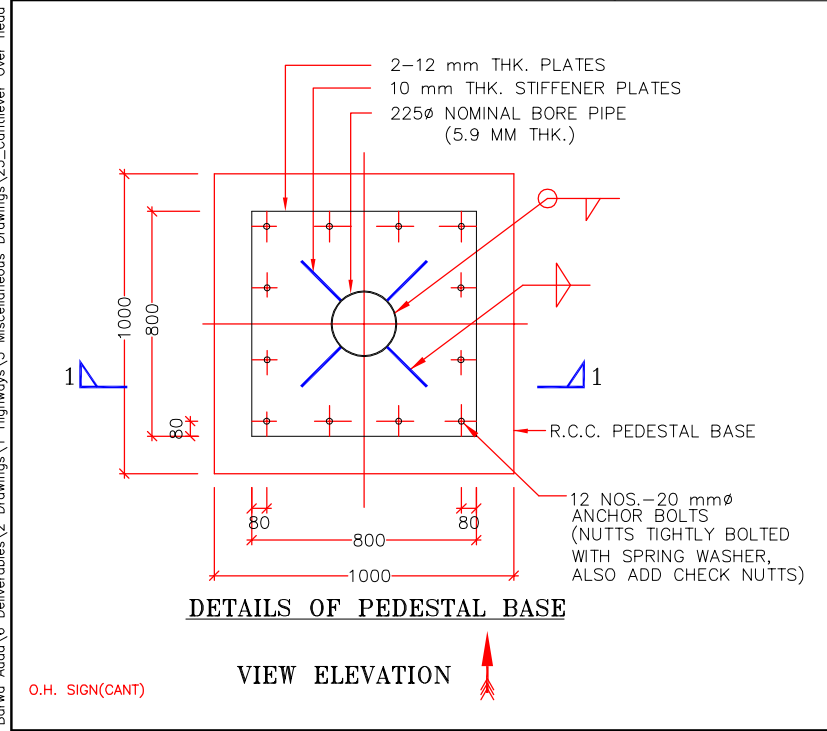

- GENERAL NOTES:-**
- ALL DIMENSIONS ARE IN mm, UNLESS OTHERWISE MENTIONED.
  - ONLY WRITTEN DIMENSIONS ARE TO BE FOLLOWED AND NO DIMENSION SHALL BE SCALED.
  - R.C.C. SHALL BE CARRIED OUT IN DESIGNED MIX M20 USING MINIMUM QUANTITY OF CEMENT 300 Kg./Cu.m OF CONCRETE AS PER I.S.: -456-2000.
  - CLEAR COVER TO THE OUTERMOST STEEL SHALL BE:-
    - i) PEDESTAL - 40mm.
    - ii) FOUNDATION - 50mm.
  - SAFE BEARING CAPACITY HAS BEEN TAKEN AS 10TONS/Sqm.
  - STEEL TUBES ARE DESIGNATED BY THEIR NOMINAL BORES INDICATED ON DRAWING.
  - STEEL TUBES USED ARE CLASSIFIED MEDIUM TYPE. (UNLESS INDICATES OTHERWISE)
  - STEEL TUBE SHALL CONFORM TO GRADE Yst 210 AS PER IS:1161-1998.
  - PIPE MEMBERS SHALL HAVE ANNULAR CUT HEAD. SMOOTH FINISHED SO AS TO HAVE PROPER SEAT OVER THE SUPPORTING TUBE.
  - ELECTRODE USED SHALL CONFORM TO RELEVANT I.S. SPECIFICATIONS AND THE CHEMICAL COMPOSITION OF ELECTRODE AND THE TUBE SHOULD MATCH.
  - SLAG SHALL BE REMOVED BEFORE MEASURING THE DIMENSIONS OF FILLET WELD.
  - WELDING SHALL BE DONE BY ARC WELDING.
  - 4.0 mm SIZE WELD SHALL BE MADE WITH A SINGLE PASS. WELDING SHALL BE DONE ALL AROUND ON THE CONTACT LENGTH OF MEMBERS.
  - HIGH STRENGTH BOLTS SHALL CONFORM TO IS:4000-1992.
  - DIA. OF HOLES IN MS PLATES SHALL BE MACHINE MADE & AS FOLLOWS. DIA OF BOLTS DIA OF HOLES
    - i) 20mm. 21.5mm.
    - ii) 16mm. 17.5mm.
  - SIZE OF LETTERS AND COLOURS OF PAINT SHALL CONFORM TO:
    - i) IRC : 67-2001
    - ii) IRC : 30-1968
  - SHADE OF ANTICORROSIVE PAINT FOR PIPES SHALL BE DECIDED BY ENGINEER INCHARGE.
  - RETRO-REFLECTIVE SHEETING SHALL BE AS PER MORT&H SPECIFICATIONS SECTION 800.
  - METALLIC CRASH BARRIER SHALL BE PROVIDED ON EARTHEN SHOULDER 50m. EITHER SIDE OF CENTER LINE OF COLUMN OF PORTAL AS PER DRAWING & MORT&H SPECIFICATIONS.



CLIENT : **NATIONAL HIGHWAYS AUTHORITY OF INDIA**

PROJECT : **Six-laning of Barwa-Adda-Panagarh Section of NH-2 from km 398.240 to km 521.120 including Panagarh Bypass in States of Jharkhand and West Bengal under NHDP Phase V on Toll on DBFOT Pattern**

INDEPENDENT ENGINEER : **S.A. Infrastructure Consultants Pvt. Ltd.**

CONCESSIONAIRE : **Barwa Adda Expressway Limited**

DESIGN BY : **IL&FS Transportation**

IL&FS Transportation Networks Limited

**GOOD FOR CONSTRUCTION**

RO	16/09/2014	FOR SUBMISSION
REV.	DATE	DESCRIPTION

DRAWN BY : I.C.

DESIGNED BY : P.P.

CHECKED BY : A.B.M.

RECOMMENDED BY : A.R.M.

APPROVED BY : H.R.B.

SCALE : AS SHOWN

TITLE : **TYPICAL DETAILS OF OVER HEAD SIGNS PORTAL TYPE FOR CANTILEVER**

DRG. NO. : **DNDA/ADV/1027-BAEL/2013/MISC/23**

REVISION : R0

DATE: 27/12/2018 - 10:57am  
PATH: \\DATA\SRV\Projects\1027 Barwa Adda\6 Deliverables\2 Drawings\1 Highways\3 Miscellaneous Drawings\23\_Cantilever Over head sign.dwg