

**BARWA ADDA EXPRESSWAY LIMITED (BAEL)**

**Consultancy Services of the Project Management Consultant for carrying out supervision of the balance construction works of Six-laning of Barwa Adda Panagarh section of NH-2 from km 398.240 to km 521.120 including Panagarh bypass in the states of Jharkhand and West Bengal under NHDP Phase V.**

**REQUEST FOR PROPOSAL (RFP)**

Site Office

Plot No. A /27, Armstrong Avenue, Bidhannagar,  
Durgapur, West Bengal – 713 212

Registered Office

The IL&FS Financial Centre, Plot C-22, G Block, Bandra Kurla Complex, Mumbai- 400051

**June 2022**

## **Barwa Adda Expressway Limited (BAEL)**

The IL&FS Financial Center, Plot C-22, G Block, Bandra Kurla Complex, Mumbai- 400051

Tel.: +91 022-26533333, Facsimile: +91 022-26523979.

E-mail: [itnl.projectbids@itnlindia.com](mailto:itnl.projectbids@itnlindia.com), Website: [www.itnlindia.com](http://www.itnlindia.com)

CIN: U45400MH2012PLC228590

---

### **INVITATION FOR BID**

**Date: June 18, 2022**

**Sub.:** Consultancy Services of the Project Management Consultant for carrying out supervision of the balance construction works of Six-laning of Barwa Adda Panagarh section of NH-2 from km 398.240 to km 521.120 including Panagarh bypass in the states of Jharkhand and West Bengal under NHDP Phase V. (Project)

Dear Sir,

- (1) M/s Barwa Adda Expressway Limited (BAEL) hereby invites sealed Bid from Bidders for the work of “Appointment of Project Management Consultant for carrying out supervision of *balance construction works of the project in various stretches within km 398.240 to km 521.120 in the state of Jharkhand and west Bengal* (Project) - Construction of Six-laning of Barwa Adda Panagarh section of NH-2 from km 398.240 to km 521.120 including Panagarh bypass in the states of Jharkhand and West Bengal under NHDP Phase V. (Project)”.

The period for completion of the consultancy works shall be **18 months**.

- (2) The Bidders may participate as per the given RFP, subject to qualification in eligibility criteria.
- (3) Bidding documents may be downloaded by the Bidders, free of cost, from the Employer’s web site [www.itnlindia.com](http://www.itnlindia.com) from ***June 18, 2022 to July 4, 2022, 11.00 Hrs.***
- (4) Bid must be accompanied by **Bid Security as per details provided in following table** for, in favor of Barwa Adda Expressway Limited, payable at Mumbai.

<b>Sr. No.</b>	<b>Particular</b>	<b>Bid Security in ₹</b>
1	Consultancy Works	₹ 1,00,000 (Rupees One Lakh Only)

Bid Security will have to be in the form as specified in the Bidding Document and shall have to be valid for **120 days beyond the validity of the Bid.**

- (5) The technical and financial bids shall be submitted through email to **itnl.projectbids@itnlindia.com**, with password protection. The password shall be sent to the dedicated email id [itnltolls.password@itnlindia.com](mailto:itnltolls.password@itnlindia.com), only for both technical and financial bids separately, on or before 1100 Hrs IST on **July 4, 2022** and hard copy delivered to office of

Barwa Adda Expressway Limited, Add: The IL&FS Financial Center, Plot C-22, G Block, Bandra Kurla Complex, Mumbai- 400051

**Signature of Authorized Officer**

## CONTENT

Sr. No.	Particulars	Page Nos.
1	<b>SECTION 1:</b> Information to Consultants	1
2	<b>SECTION 2:</b> Letter of Invitation	5
	<b>Datasheet</b>	16
	<b>Appendix-EC</b>	23
3	<b>SECTION 3:</b> Format for Submission of Firms Credentials.	45
4	<b>SECTION 4:</b> Format for Submission of Technical Proposal.	50
	<b>Appendix B-1-</b> Technical proposal submission form.	51
	<b>Appendix B-2-</b> Site Appreciation	52
	<b>Appendix B-3-</b> Approach paper on methodology for performing the assignment	53
	<b>Appendix B-4-</b> Facility for field investigation and testing	54
	<b>Appendix B-5-</b> Composition of the Team and Task(s) of each Team member	55
	<b>Appendix B-6-</b> Curriculum vitae of proposed Professional staff.	56
	<b>Appendix B-7-</b> Time schedule for deployment of Professional staff	58
	<b>Appendix B-8-</b> Activity (works) schedule.	59
	<b>Appendix B-9-</b> Affidavit – Correctness of Experience claimed by the Firms	60
	<b>APPENDIX B-10-</b> Deleted	61
	<b>Appendix B-11-</b> Determination of Technical Capacity	62
5	<b>SECTION 5:</b> Format for submission of Financial proposal.	65
	<b>Appendix C-1</b> Financial proposal submission form	66
	<b>Appendix C-2</b> Summary of costs	67
	<b>Appendix C-3</b> Breakdown of costs	68
6	<b>SECTION 6:</b> Terms of Reference.	72
	<b>Enclosure-A</b>	83
	<b>Enclosure-B</b>	85
	<b>Annexure I-</b> Daily Inspection Report in construction period	99
	<b>Annexure II-</b> Daily Inspection Report in O&M period - Deleted	100

<b>Sr. No.</b>	<b>Particulars</b>	<b>Page Nos.</b>
	<b>Annexure III-</b> Weekly Inspection Report in O&M period – Deleted	101
	<b>Annexure IV-</b> Month of survey for equipment based road condition assessment – Deleted	102
	<b>Annexure V-</b> Monthly Progress Report in Construction Phase	103
	<b>Annexure VII:</b> Output Format From Network Survey Vehicle And FWD Testing – Deleted	134
7	<b>SECTION 7:</b> Draft Form of Contract.	135

## REQUEST FOR PROPOSAL (RFP)

### SECTION 1: INFORMATION TO CONSULTANTS

Sub.: Consultancy Services of the Project Management Consultant for carrying out supervision of the balance construction works of Six-laning of Barwa Adda Panagarh section of NH-2 from km 398.240 to km 521.120 including Panagarh bypass in the states of Jharkhand and West Bengal under NHDP Phase V. (Project).

1. The Barwa Adda Expressway Limited (BAEL) (the 'Employer') invites proposals from eligible Consultants for engaging a Project Management Consultant (PMC/Consultant) on the basis of International Competitive Bidding for the following contract package in the State of Jharkhand and West Bengal:

**TABLE1: DETAILS OF PROJECT**

S No	Consultancy Package	NH No.	State	Project Stretch	Project Length (Km) / Estimated Project Cost (Cr.)	Estimated Assignment period (months)
1	BAEL/RFP/Balance Work/ Pkg-...	NH-2	Jharkhand and West Bengal	Barwa Adda Panagarh section of NH-2 from km 398.240 to km 521.120 including Panagarh bypass in the states of Jharkhand and West Bengal- Balance works in various stretches	121 km/ Rs. 409.52 Cr.	18 Months from LOA

2. The RFP has also been uploaded on The Employer /ITNL web page (<http://www.itnlindia.com/ad.html#>).
3. Bid must be send to email id [itnl.projectbids@itnlindia.com](mailto:itnl.projectbids@itnlindia.com), via soft copy mode (**All the bids heavy in size can be submitted via link**) on or before **1100 hrs on July 4, 2022**
4. The proposal shall be submitted in English Language and all correspondence would be in the same language.
5. The Employer intends to appoint a Consultant to act as Project Management Consultant for implementation of the Project. The Project Management Consultant shall perform all the duties as per TOR given in this RFP along with any amendment thereof.

6. The interested consultancy firms may download the RFP document from the official website of the Employer w.e.f. **June 18, 2022 to July 4, 2022 upto 11:00 hrs.**
7. The proposal should be submitted by consultancy firms in two parts. The two parts of the proposal are Part1: Technical Proposal and Part2: Financial Proposal. For a given Project, Stage -1 of the Evaluation shall consider the evaluation of the Technical Proposal (i.e. Part 1). The firms scoring the qualifying marks (minimum 75%) as mentioned in RFP shall only be considered for further evaluation. Under stage 2, the financial proposal of such firms as selected above shall be opened and evaluated. Proposals will finally be ranked according to their combined technical and financial scores as specified in clause 5 of section 2.
8. The total time period for the assignment as Project Management Consultant will be for 18 months. However the same may be revised based on site requirement.
9. Consultants must apply only as a sole firm and Joint Ventures are not allowed.
10. The Applicant may include any number of Associate to provide technology in assignment (refer para 10 (iii) of data sheet). The Associate firm can provide equipment based road inspection services for any of the 4 equipment viz., (i) Network Survey Vehicle including all modules required as per technical specifications, (ii) Falling Weight Deflectometer, (iii) Mobile Bridge Inspection Unit and (iv) Retro Reflectometer. However, the Associate(s) cannot be common for 2 or more bidders. If any Associate is common with 2 or more bidders, all those bids shall be declared non-responsive. Hence, the bidder may ensure on his own that the associate proposed by him is not proposed by any other bidder participating in the same assignment and the bidder is solely responsible in this regard.
11. The Applicant, by submitting its bid pursuant to this RFP, shall be deemed to have acknowledged that without prejudice to the Employer any other right or remedy hereunder or in law or otherwise, the Applicant shall be debarred from participating in the future projects of the Employer in the following situations
  - (a) If an Applicant withdraws its Proposal during the period of its validity as specified in this RFP and as extended by the Applicant from time to time.
  - (b) In the case of a Selected Applicant, if the Applicant fails to sign the Agreement.
12. Consulting firms meeting the following criteria are only eligible for applying for this assignment. Firms not meeting these criteria, need not apply.

S. No.	Experience of the firm in last 7 years		Annual Turnover***
	Preparation of DPR (NH/SH/Equivalent)	Project Supervision/IC (NH/SH/Equivalent)	
1 (a)	The firm should have minimum experience of preparation of detailed Project Report/ Feasibility Study cum Preliminary Design Report of 2/4/6**-laning/Bridge project of aggregate length equal to 2 times or more of similar category for which RFP is invited.	The firm should have minimum experience of Project Supervision/ Independent Engineer/ Consultant of 2/4/6**-laning/ Bridge project of aggregate length equal to 3 times or more of similar category** for which RFP is invited.	Annual turnover (updated average of last 3 years) of the firm from consultancy business should be equal to or more than 2% of Estimated Project Cost.
1 (b)		Firm should also have experience of Project Management/Project Supervision/ Independent Engineer/ Authority/ Engineer of at least one project of similar category of two/four/six** laning/bridge work of length equal to 40% of project length	
		Additional requirement in case of specialized projects***	

\*\* Similar project means 2/4/6 lane as applicable for the project for which RFP is invited.. Experience of 4/6 lane shall be considered interchangeably for 4/6 laning projects. For 4/6 laning projects, experience of 2 lane will be considered with a multiplication factor of 0.4, but only for those 2 lane projects whose cost of consultancy services was more than Rs.3.0 crores..

\*\*\* In case the project includes any specialized nature of work such as tunnels, specialized structures etc. in substantial quantum, this requirement may be suitably included.

**13.** In case the financial figures and values of services provided are in foreign currency current market exchange rate (The conversion rate of USD into Rupees shall be the daily representative exchange rates published by the Reserve Bank of India for the relevant date. Where relevant date should be as on the date 7 (seven) days prior to the Bid Due Date) will be applied for the purpose of conversion of amount in foreign currency into Indian Rupees.

**14.** The Bidder should, in the last 2 years, have neither failed to perform for the consultancy services pertaining to Expressways, National Highways, ISC (Inter State Connectivity) & EI (Economic Importance) works, as evidenced by imposition of a penalty by an arbitral or judicial authority or a judicial pronouncement or arbitration award against the Bidder nor has been expelled/debarred/declared as nonperformer or terminated by Ministry of Road Transport & Highways or its implementing agencies for breach by such Bidder. The Bidder



who do not fulfil the aforesaid condition as on last date of submission of proposal and as on date of issue of Letter of Acceptance, shall not be considered for placement of contract.

Contracts concluded before the issue of the debarment/declaration as non-performer order shall not be affected by the debarment order(s) issued subsequently.

In case, any debarred/declared non-performer firm submits the bid, the same will be ignored. In case such firm is lowest (L-1), next lowest firm shall be considered as L-1.

15. Employer will not be responsible for any delay, loss or non-receipt of RFP document sent by post/courier. Further, Employer shall not be responsible for any delay in receiving the proposal and reserves the right to accept/reject any or all bids without assigning any reason thereof.
16. The two parts of the Proposal (Technical proposal and Financial proposal) must be submitted on-line only with all pages numbered serially, along with an index of submission as per procedure under this RFP. Physical submission of the proposal shall not be accepted. In the event, any of the instructions mentioned herein have not been adhered to, the Employer may reject the Proposal.
17.
  - a. The Selected Bidder shall use the designated email IDs mentioned in the document to communicate with the Employer for all contractual correspondence.
  - b. No physical document shall be accepted unless and until the same is specifically stated so in the RFP or it is a legal requirement.
18. RFP submission must be received not later than **11:00 hrs on July 4, 2022 (“Bid Due Date”)** in the manner specified in the RFP document at the address given below.

**Address of Employer:**

Registered Office

Barwa Adda Expressway Limited (BAEL), The IL&FS Financial Centre, Plot C-22, G Block, Bandra Kurla Complex, Mumbai- 400051

E-mail: [itnl.projectbids@itnlindia.com](mailto:itnl.projectbids@itnlindia.com)

## SECTION 2: LETTER OF INVITATION TO CONSULTANTS

### 1 INTRODUCTION

- 1.1 Bids are invited from consulting firms either as a sole firm willing to act as PMC to submit a proposal for providing consulting services required for the assignment named in the attached Letter of Invitation.
- 1.2 A brief description of the assignment and its objectives are given in the Terms of Reference (TOR).
- 1.3 The assignment shall be implemented in Construction Period (18 Months).
- 1.4 This RFP is neither an agreement nor an offer by the Employer to the prospective Applicants or any other person. The purpose of this RFP is to provide interested parties with information that may be useful to them in the formulation of their Proposals pursuant to this RFP. This RFP includes statements and assumptions, which reflect various assessments arrived at by the Employer in relation to the Consultancy. Such assessments and statements do not purport to contain all the information that each Applicant may require. The information contained in this RFP, may not be complete, accurate, adequate or correct. Each Applicant should, therefore, conduct its own investigations about the assignment and the local conditions before submitting the proposal by paying a visit to the Employer and the project site, sending written queries to the Employer, before the date and time specified in the Data Sheet.
- 1.5 Please note that (i) the costs of preparing the proposal and negotiating for the contract, including a visit to site, are not reimbursable as a direct cost of assignment and (ii) Employer is not bound to accept any of the proposals received by it and reserves the right to annul the selection process at any time prior to contract award, without thereby incurring any liability to the Consultants.
- 1.6 Consultant have an obligation to disclose any situation of actual or potential conflict that impacts their capacity to serve the best interest of their Employer, or than may reasonably be perceived as having this effect. Failure to disclose said situations may lead to the disqualification of the Consultant Or the termination of its Contract and/or any other action as deemed fit by the Employer at any stage.
- 1.7 It is the Employer policy that the consultants observe the highest standard of ethics during the selection and execution of such contracts. In pursuance of this policy, the Employer:
- (a) Defines, for the purpose of this paragraph, the terms set forth below as follows:
- (i) **“Corrupt Practice”** means the offering, giving, receiving, or soliciting, directly or indirectly, of anything of value to influence the action of a public official in the selection process or in contract execution;
- (ii) **“Fraudulent Practice”** means a misrepresentation or omission of facts in order to influence a selection process or the execution of a contract;



documents by amendment. Any amendment shall be issued in writing through addendum. Addendum may be sent by mail, cable, telex, facsimile or electronic mail to consultants or/and will be hosted on Employer's website which will be binding on them. The Employer may at its discretion extend the deadline for the submission of Proposals.

### **3. PREPARATION OF PROPOSAL**

**3.1** You are requested to submit your proposal in Two Parts strictly using the formats enclosed herewith (refer section 3, 4 and 5) in 2 separate envelopes/ packages and put together in one single outer envelope/ package. The two parts shall be:

#### **Part 1: Technical Proposal and**

#### **Part 2: Financial Proposal.**

The proposal shall be written in the English language as specified in the Data Sheet. All pages of the Proposal shall be signed by an authorized representative. The representative's authorization shall be confirmed by written Power of Attorney duly notarized to be submitted with the proposal.

#### **Part 1: Technical Proposal**

**3.2** You are expected to examine all terms and conditions included in the documents.

Failure to act or to provide all requested information will be at your own risk and may result in rejection of your proposal.

**3.3** During preparation of the Technical proposal you may give particular attention to the following:

- i. The man-months for the assignment shall be that stated in the Terms of Reference. The same shall be considered for the purpose of evaluation as well as award. In case the man months of TOR are amended in view of Client's own initiative or in response to clarification sought by any Consulting firm, the man months so amended and published shall be considered for the purpose of evaluation as well as award.
- ii. The Consultants should prefer to field as many of their permanent staff as possible. The permanent staff would be considered those already employed with the firm prior to one year from the month during which this Tender Notice is issued. Applicant shall submit the details of the period of employment of the proposed personnel with the firm.
- iii. A good working knowledge of the language specified in the data sheet is essential for key professional staff on this assignment. Reports must be in the language (s) specified in the data sheet

**3.4** Your Technical Proposal must provide the following information, using but not limited to the formats attached in the Section 3 & 4.

- i. A brief description of the firm's organisation and an outline of recent experience of the Consultants on assignments of a similar nature. The information which you shall provide

---

Consultancy Services of PMC for supervision of balance Construction of Six-laning of Barwa Adda Panagarh section of NH-2 from km 398.240 to km 521.120 including Panagarh bypass in the states of Jharkhand and West Bengal under NHDP Phase V on DBFOT basis (Project)

on each assignment should indicate, *inter-alia*, the profiles of the staff provided, duration, contract amount and firm's involvement. ***The details of assignments on hand shall also be furnished by the Consultant separately.***

- ii. Any comments or suggestions on the ToR and a description of the methodology (work plan) which the firm proposes to execute the services, illustrated with bar charts of activities.
- iii. Site Appreciation: limited to four A4 size pages in 1.5 space and 12 font including photographs, if any;
- iv. Proposed methodology for the execution of the services illustrated with bar charts of activities, including any change proposed in the methodology of services indicated in the TOR, and procedure for quality assurance: Maximum 4 pages;
- v. The proposed methodology should be accompanied by the consultants initial view, key challenges they foresee and potential solutions. It should also include details on adoption of superior technology along with proof: limited to six A4 size pages in 1.5 space and 12 font including photographs;
- vi. The proposal shall indicate as to whether the firm is having the facilities for carrying out the following field activities or these are proposed to be outsourced to specialized agencies.
  - Surface defects detection and roughness measurement using Network Survey Vehicle
  - Pavement strength measurement using FWD
  - Bridge inspection using Mobile Bridge Inspection Unit
  - Road signs inspection using Retro Reflectometer
- vii. Proposed Quality Audit Methodology including Quality Assurance Plan
- viii. In case the Consultant envisages outsourcing any or all of the above services to the expert agencies, the details of the same indicating the arrangement made with the agencies need to be furnished. These agencies would however, be subject to approval of the client to ensure quality input by such agencies before award of the work. For out-sourced services, proposed firms/consultants should have such experience on similar projects.
- ix. The composition of the proposed staff team, the tasks which shall be assigned to each and their timing;
- x. Requirement for submission of CVs.
  - a. The CVs of following key personnel in the format as per Appendix-B-6 is to be furnished.  
Team leader cum Senior Highway Engineer, Resident cum Highway Engineer, Bridge/Structural Engineer, Senior Pavement Specialist, Senior Quality cum Material Expert and Road Safety Expert

It may please be ensured that the format is strictly followed and the information furnished therein is true and correct. The CV must indicate the work in hand and the duration till which the person will be required to be engaged in that assignment. The Firm shall ensure that details furnished in the CV by the personnel are correct. If any

information is found incorrect, at any stage, debarment of the key personnel from future projects by the Employer upto 2 years may be taken by the Employer.

- b. Key information should include years with the firm and degree of responsibility held in various assignments. In CV format, at summary, the individual shall declare his qualification & total experience (in years) against the requirements specified in TOR for the position (Ref. Enclosure-B of TOR). If any information is found incorrect, at any stage, debarment of the key personnel from future projects by the Employer upto 2 years may be taken by the Employer.
- c. All the CVs which are to be evaluated should be complete in all respects including signing and certification by the individual and the firm.
- d. Minimum 75% marks required in aggregate for CV of Key Personnel. CV of proposed Team Leader should score at least 75% marks. If not, the proposal shall not be considered further.
- e. If a CV score less than 75% marks, whatever marks it score will be carried forward for maximum 3 nos. key personnel for determining the total score of the firm. However, if the Key Personnel does not fulfill the minimum academic qualification (as mentioned at Enclosure-B of TOR of RFP), the overall score of his CV will be evaluated as zero. If the Key Personnel does not fulfill the minimum qualification related to experience (as mentioned at Enclosure-B of TOR of RFP), then zero marks will only be assigned for that sub criteria, but the marks obtained by the CV of the Key Personnel will be carried forward for maximum 3 nos. key personnel for determining the total score of the firm. In case, a firm is H-1, then all such Key Personnel (whose CV scores less than 75% or who does not fulfill the minimum qualification) will have to be replaced by the firm before signing the contract. The reduction in remuneration of such replacements shall be 10% for each replacement. In case more than 3 CV scores less than 75% marks or Team leader cum Senior Highway Engineer scores less than 75% marks, the proposal shall be considered non-responsive.
- f. In case, the information contained in the CV for the duration in which the key personnel:
  - A. was employed by the firm, proposing his candidature is found incorrect/fake/inflated at any stage, action including termination of the Consultancy Agreement and debarment of the firm upto 02 years from future projects by the Employer shall be taken by the Employer.
  - B. was employed by the firm, proposing his candidature is found incorrect/fake/inflated at any stage, the consultancy firms shall have to refund the salary and perks drawn in respect of the person apart from other consequences.
  - C. was not employed by the firm, proposing his candidature is found incorrect/fake/inflated at any stage, the consultancy firms will have to refund the twice of salary and perks drawn in respect of the person.

- g. It is also clarified that any key personnel, if debarred during the period between receipt of bid and award of the contract and is required to be replaced as per the provisions of the RFP, then the replacement shall not be considered as part of replacement by the Project Management Consultant and hence no deduction in remuneration shall be affected. However, in this case the original CV will be considered for evaluation purpose
- xi. Deployment Schedule for each key personnel should be formulated and incorporated in the Technical Proposal which will be reviewed on quarterly basis.
- xii. Estimates of the total time effort (person x months) to be provided for the services, supported by bar chart diagrams showing the time proposed (person x months) for each professional staff and sub professional staff.
- xiii. In case, consultant firm's experience/documents is found to be false at any stage i.e. from bidding to completion of services, the Consultancy Contract shall be terminated and Consultant firm shall be debarred for a period of 02 years.

3.5 The technical proposal must NOT include any financial information.

### 3.6 Interviews of Key Personnel of Consultants:

The Expert Teams will be set up by the Employer to take the interviews through VC of the Key Personnel of H-1 Consultant before issue of LOA of consultancy assignments under their jurisdiction. The Consulting Firm will have to replace unsuitable person with a person of equal or better CV.

### 3.7 Bid Security

- i. The Bidder shall furnish, as part of his Bid, a Bid Security for an amount mentioned in Invitation for Bid. This Bid Security shall be in favor of "Barwa Adda Expressway Limited" Payable at Mumbai

Account Details:

Name of Beneficiary :	Barwa Adda Expressway Limited (BAEL)
Name of Bank:	BANK OF BARODA
Account No.	29100200000238
IFSC Code:	BARB0CFSBAL

and may be in one of the following forms:

- A Bank Guarantee, in the prescribed format is acceptable from the following institutions located in India:
  - (a) State Bank of India or its subsidiaries;
  - (b) Any Indian Nationalized /Scheduled Bank;
  - (c) Foreign Bank with operations in India provided the net worth in respect of the Indian operations shall not be less than ₹500 Cr. as per the latest Annual Report of the Bank and that Bank Guarantee is issued by a branch in India.



- Bankers' cheque or Demand draft in favor of "Barwa Adda Expressway Limited" payable at Mumbai.
- ii. Bank guarantees issued as surety for the Bid should be valid for 120 days beyond the validity of the Bid.
- iii. Any Bid not accompanied by an acceptable Bid Security and not secured as indicated in Sub Clauses 3.7 i and 3.7 ii shall be rejected by the Employer as non-responsive.
- iv. The Bid Security of unsuccessful Bidders other than the evaluated responsive lowest three Bidders will be returned within 30 days of the completion of the bid evaluation process and within the bid validity period, specified in Datasheet. The Bid Security of two of the lowest three Bidders, other than the successful Bidder, shall be returned after signing of the Contract Agreement with the successful Bidder.
- v. The Bid Security of the successful Bidder will be discharged when the Bidder has signed the Agreement.
- vi. The Bid Security may be forfeited
  - a. if the Bidder withdraws the Bid after Bid opening during the period of Bid validity;
  - b. if the Bidder does not accept the correction of the Bid Price, pursuant to Clause 27; or
  - c. in the case of a successful Bidder, if the Bidder fails within the specified time limit to
    - i. submit Performance Security, and/or
    - ii. sign the Agreement.

## **Part 2: Financial Proposal**

- 3.8 Your Financial Proposal must be strictly using the formats attached in Section 5. No additional items/quantities other than that specified in the formats should be proposed by the Consultants since the same shall not be considered for the evaluation/award. Consultants shall be paid billing rates for services as per financial proposal submitted by them basis. However, for evaluation and award of the Bid proposals, the quoted initial rate shall be multiplied by the total time input for each position on this contract, i.e. without considering the increase in the billing rates. All payments shall be made in Indian Rupees and shall be subjected to applicable Indian laws withholding taxes if any.
- 3.9 The Financial Proposal should clearly identify as a separate amount, the local taxes (including social security), duties, fees, levies and other charges imposed under the applicable law, on the consultants, the sub-consultants, and their personnel (other than nationals or permanent residents of the government's country); unless the Data Sheet specifies otherwise. This cost, however, will not be considered in evaluation.



- 3.10 Consultants may express the price of their services in the Indian Rupees only.
- 3.11 Goods & Service tax as applicable shall be paid to the Consultant while making payment for services rendered. The consultants shall then deposit the same with the tax authorities and provide a proof of having done so within next 90 days. Employer shall pay only the Goods & service tax.

#### **4. SUBMISSION, RECEIPT AND OPENING OF PROPOSALS**

##### **4.1 PREPARATION & SUBMISSION OF PROPOSALS:**

- A. Detailed RFP may be downloaded from website of Employer and the proposal may be submitted online following the instructions appearing in the RFP.
- B. The following shall be the form of various documents in the proposal:

##### **Technical Proposal {Only Electronic Form (to be submitted on email ID of Employer)}**

- (a) Power of Attorney for signing the bid
  - (b) Bid Security;
  - (c) Deleted;
  - (d) Copy of Memorandum of Understanding with Associate, if applicable.
  - (e) Firms credentials as per format prescribed in SECTION-3 OF RFP. (The details are to be submitted alongwith the Bid)
  - (f) Technical proposal as per format prescribed in SECTION-4 OF RFP. (The details are to be submitted alongwith the Bid)
  - (g) Apostile of documents/certificates of foreign origin.
  - (h) Financial proposal as per format prescribed in section – 5 of RFP
- C. The successful bidder shall submit the original documents specified above in point no.4.1 B (I) (a), (b), (c)& (d) above together with their respective enclosures to the Employer before signing of the Agreement.
- i.) The Applicant shall submit scanned copies of the Technical Proposal and Financial Proposal as specified in point nos. **4.1 (B)** above on the email ID of Employer before 11:00 hours Indian Standard Time on the bid due date. Financial Proposal is to be submitted On-line only and no hard submission is to be made.

##### **4.2 MODIFICATION / SUBSTITUTION/ WITHDRAWAL OF BIDS:**

- (i) The Bidder may modify, substitute or withdraw its e- bid, prior to the Bid Due Date. No Bid shall be modified, substituted or withdrawn by the Bidder on or after the Bid Due Date.
- (ii) Any alteration/ modification in the Bid or additional information supplied subsequent to the Bid Due Date, unless the same has been expressly sought for by the Employer, shall be disregarded.

- (iii) For modification or withdrawal of bid, bidder has to submit the modified bid prior to Bid Due Date on email ID of the Employer specifically marking "MODIFICATION" or "WITHDRAWAL", as appropriate.

#### **4.3 OPENING AND EVALUATION OF PROPOSALS:**

- (i) Opening of Proposals will be done through online for both Financial Proposal and Technical Proposal.

The Employer will open the Technical Proposal and evaluate the bids in accordance with the provisions set out in the RFP.

- (ii) The Financial Proposal will be opened of the short listed applicants who qualify for financial opening as per RFP. The date of opening of Financial Proposal will be notified later on.

### **5 PROPOSAL EVALUATION**

5.1 A two -stage procedure shall be adopted for evaluating the proposals.

5.2 Deleted

#### **Technical Proposal**

5.3 The Evaluation Committee appointed by the Employer shall carry out its evaluation applying the evaluation criteria and point system specified in the data sheet. Each responsive proposal shall be attributed a technical score (S<sub>T</sub>.) Only those Applicants whose Technical proposal score 75 marks or more out of 100 shall qualify for further consideration. However, if the number of such pre-qualified bids is less than two, the Employer may, in its sole discretion, pre-qualify the applicant(s) whose technical score is less than 75 marks.

#### **Financial Proposal**

5.4 After the evaluation of Technical Proposals is completed and the shortlist of firms is finalised, the Employer may notify those consultants whose proposals were not considered as per conditions of RFP. The Employer shall simultaneously notify the shortlisted firms indicating the date and time set for opening of the Financial Proposals.

5.5 The Financial Proposals shall be opened on the date of opening of the financial bid.. The Client shall prepare minutes of the opening.

5.6 The Evaluation Committee will determine whether the submitted Financial Proposals are complete (i.e. whether they have included cost of all items of the corresponding proposals; if not, then the cost towards such missing items will be considered as NIL, but the Consultant shall, however, be required to carry out such obligations without any additional compensation.) and without computational error. In case under such circumstances, if Client feels that the work cannot be carried out within the overall cost as per the submitted financial proposal, such proposals shall be considered non responsive.

- 5.7 The lowest financial proposal ( $F_M$ ) will be given a financial score ( $S_F$ ) of 100 points. The financial scores of other proposals will be computed as follows:

$$S_F = 100 \times F_M / F \text{ (F= amount of financial proposal)}$$

- 5.8 Proposals will finally be ranked according to their combined technical ( $S_T$ ) and financial ( $S_F$ ) scores as follows:

$$S = S_T \times T_w + S_F \times F_w$$

Where S is the combined score, and  $T_w$  and  $F_w$  are weights assigned to Technical Proposal and Financial Proposal that shall be 0.80 and 0.20 respectively.

- 5.9 The selected Project Management Consultant shall be the first Ranked Applicant (H-1, having the highest combined score). In the event the proposals of two or more consultants have the same scores in the final ranking, the proposal with the highest technical score should be ranked first.

## 6 AWARD OF CONTRACT

The Client shall issue letter of award to selected Consultant and ask the Consultant to provide Performance Security as in Para 7 below. If the selected Consultant fail to provide performance security within the prescribed time or the Consultant fail to sign the Contract Agreement within prescribed time, the Client may invite the 2<sup>nd</sup> highest ranking bidder Consultant and follow the procedure outlined in Para 6 and 8 of this Letter of Invitation.

## 7 PERFORMANCE SECURITY

- 7.1 The successful consulting firm shall have to submit a Bank Guarantee (BG) for an amount of 5% of the Contract Value within 15 days of issue of LOA. The BG shall be valid for a period of 21 months i.e. upto 3 months beyond the expiry of the Contract period of 18 months. The BG shall be in the format specified in Appendix H of draft contract form and furnished from a Nationalised Bank, IDBI or ICICI/ICICI Bank/Foreign Bank/EXIM Bank / Any Scheduled Commercial Bank approved by RBI having a net worth of not less than 1000 crore as per latest Annual Report of the Bank. In the case of a Foreign Bank (issued by a Branch in India) the net worth in respect of Indian operations shall only be taken into account. In case of Foreign Bank, the BG issued by Foreign Bank should be counter guaranteed by any Nationalised Bank in India.
- 7.2 In the event the Consultant fails to provide the security within 15 days of date of LOA, it may seek extension of time for a period of 15 (Fifteen) days on payment of damages for such extended period in a sum of calculated at the rate of 0.1% (Zero Point One Percent) of the contract price for each day until the performance security is provided. For the avoidance of doubt the agreement shall be deemed to be terminated on expiry of additional 15 days' time period.
- 7.3 Notwithstanding anything to the contrary contained in this Agreement, the Parties agree that in the event of failure of the Consultant to provide the Performance Security in accordance with

the provisions of Clause 7.1 within the time specified therein or such extended period as may be provided by the Employer, in accordance with the provisions of Clause 7.2 and thereupon all rights, privileges, claims and entitlements of the Consultant under or arising out of this Agreement shall be deemed to have been waived by, and to have ceased with the concurrence of the Consultant, and LoA shall be deemed to have been withdrawn by mutual agreement of the Parties. The Employer may take action debar such firm for future projects for a period of 1-2 years.

## **8. Signing of Contract Agreement**

After having received the performance security and verified it, the Client shall invite the selected bidder for signing of Contract Agreement on a date and time convenient to both parties within 15 days of receipt of valid Performance Security.

## DATASHEET

### (As Mentioned in Letter of Invitation to Consultants)

#### Sub clause No. in Letter of Invitation to Consultants

- 1 The proposal shall be valid for 120 days after the last date of submission.
- 2 Clarification may be requested 7 days prior to Bid Due Date. The address for requesting clarification is:

Mr. ....,

Registered Office

Barwa Adda Expressway Limited (BAEL), The IL&FS Financial Centre, Plot C-22, G Block, Bandra Kurla Complex, Mumbai- 400051

E-mail: [itnl.projectbids@itnlindia.com](mailto:itnl.projectbids@itnlindia.com)

- 4 **The Language** of documents and correspondence will be English
- 5 All the personnel shall have working knowledge of English and all the reports etc shall be written in English.
- 6 The Employer shall reimburse only Goods and service tax. Project Management Consultant has to assess all other taxes and should inbuilt them in their financial proposal. These taxes (other than Goods and service tax) should not be provided separately. Consultants are requested to consult Tax Consultants for details.
- 7 The Consultants to state cost in INR.
- 8 The time and date of submission:

**Online: On or before 11.00 hrs on July 4, 2022**

- 10 **The points assigned to Technical Evaluation criteria are:**

S. No.	Description	Marks
1	Relevant experience for the assignment	40
2	Experience in use of technology for road inspection	20
3	Qualifications and competence of the key staff for the assignment	40
	<b>Total</b>	<b>100</b>

**i. Sub criteria for Relevant Experience of the firm for the assignment**

1	Average Annual Turnover (last 3 years) from consultancy business (Min 5 crore)	2
2	Nos of Highway Professionals with the firm *The professionals who possess degree in Civil Engineering /Transport Planning /Transport Economics /Traffic Management / Geology/ Environment Science or Engineering and 8 years experience in highway/bridge/tunnel with employment in the firm for more than one year. The current Employment Certificate shall be submitted.	10
3	Experience as Independent Engineer/Construction Supervision Engineer/Construction Supervision in Number of Highway Projects of length equal to 40% of project length of similar category for which RFP invited of 2/ 4/6**-laning or more in last 7 years*	10
4	Experience in DPR preparation for Number of Highway Projects (of length 40% of project length of similar category for which RFP invited of 2/4/6**-laning or more) in last 7 years*	5
5	In hand DPRs for Authority (Ministry /NHAI/NHIDCL-As applicable) Projects (presently under progress)	10
6	Experience in Construction Supervision/DPR /Design Review of Major structures having length of more than 500 meter in last 7 years.	3
7	Additional requirement in case of specialized projects***	***

*\*Consultants should give details of the experience of the firm considering the completed and the on-going highway assignments, separately for PPP and non-PPP Projects along with experience certificates from clients. This list of the completed works should also include those assignments which are substantially (90% of Contract value) completed. No Qualification/Experience etc. shall be considered without proof of experience.*

*Experience of Consultant for having offered consultancy services to a private organization shall also be considered as relevant experience for current assignment, provided the experience is duly endorsed by the respective Government Agency.*

**\*\*** Similar projects means 2/4/6 lane as applicable for the project for which RFP is invited. Experience of 4/6 lane shall be considered interchangeably for 4/6 laning projects. For 4/6 laning projects, experience of 2 lane will be considered with a multiplication factor of 0.4, but only for those 2 lane projects whose cost of consultancy services was more than Rs.3.0 crores.

**\*\*\*** In case the project includes any specialized nature of work such as tunnels, specialized structures etc. in substantial quantum, this requirement/Marks may be included by suitably adjusting marks of other attributes.

ii. Sub criteria for Experience in use of technology for road inspection

Sr. No.	Description	Maximum Points	Sub-Points
<b>1</b>	<b>Experience in Network Survey Vehicle (NSV) or better technology for pavement inspection</b>	<b>7</b>	
<b>1.1</b>	Own <b>Equipment</b> / Equipment on MOU with Associate or on hiring basis	<b>4</b>	
<b>1.2</b>	<b>Experience</b>	<b>3</b>	
	(a) 1-2 projects		1
	(b) 3-5 projects		2
	(c) >5projects		3
<b>2</b>	<b>Experience in Falling Weight Deflectometer (FWD) or better technology for pavement strength measurement</b>	<b>4</b>	
<b>2.1</b>	Own Equipment/ Equipment on MOU with Associate or on hiring basis	<b>2</b>	
<b>2.2</b>	<b>Experience</b>	<b>2</b>	
	(a) 1-3 projects		1
	(b) > 3 projects		2
<b>3</b>	<b>Experience in Mobile Bridge Inspection Unit or better technology for bridge inspection</b>	<b>5</b>	
<b>3.1</b>	Own Equipment/ Equipment on MOU with Associate or on hiring basis	<b>2</b>	
<b>3.2</b>	<b>Experience</b>	<b>3</b>	
	(a) 1-2 projects		1
	(b) 3-5 projects		2
	(c) > 5 projects		3
<b>4</b>	<b>Experience in Retro reflectometer technology</b>	<b>4</b>	
<b>4.1</b>	Own Equipment/ Equipment on MOU with Associate or on hiring basis	<b>2</b>	
<b>4.2</b>	<b>Experience</b>	<b>2</b>	
	(a)1-3 projects		1
	(b)> 3 projects		2
	<b>Total</b>	<b>20</b>	

**Note:**

- A. The Project Management Consultant owning the equipment's shall be required to submit proof of ownership.
- B. The experience of the associate firms in use of technology shall also be counted in the evaluation. The experience of firm or associate firm in NSV or equivalent technology, FWD

---

Consultancy Services of PMC for supervision of balance Construction of Six-laning of Barwa Adda Panagarh section of NH-2 from km 398.240 to km 521.120 including Panagarh bypass in the states of Jharkhand and West Bengal under NHDP Phase V on DBFOT basis (Project)

or equivalent technology, MBIU or equivalent technology and Retro reflectometer or equivalent technology shall be supported by experience certificate. The experience of a firm/ associate firm for a private concessionaire/contractor (client) shall be considered provided the experience is duly endorsed by the respective government agency.

- C. In case, Ownership document of equipment of Consultancy firm is found to be false, if during the bid process, their bid shall be rejected and if thereafter, the consultancy firm shall be penalised upto 10% of their aggregate fees.
- D. The consultant shall provide an undertaking for the use of technology in the following format-



### **Undertaking to be given on letter head of the firm**

We M/s (Name of the firm) undertake that the invoice and specifications of equipment for use of technology (i.e. NSV, FWD, and RR etc.) provided by us in the bid is adequate to fulfil the requirements of these equipment at the site as prescribed in the RFP.

In case it is found at a later stage that the equipment submitted by us in the bid is not adequate to fulfil the requirements of the RFP, BAEL is free to take any action against us including debarment from future BAEL projects as deem fit.

(Authorized Signatory)

**Qualification and competence of following professional/sub-professional staff** for the assignment shall be evaluated. The weightage for various key staff are as under:-

S. No	Staff Position	No. of positions	Marks for each position	Total Marks.
1	Team Leader Cum Senior Highway Engineer	1	10	10
2	Resident cum Bridge Engineer	1	6	6
3	Bridge/Structural Engineer	1	3	3
4	Highway Engineer	2	3	6
5	Senior Quality cum Material Expert	2	3	6
6	Road safety Expert	1	3	3
7	Quantity Surveyor / Planning Engineer	2	2	4
8	Survey Engineer	2	1	2
	<b>Total</b>			<b>40</b>

**Sub criteria for qualification of Key Personnel (i.e. Professional staff)**

General qualifications	25
Adequacy for the project	70
Employment with firm	5
Total	100

The technical proposal should score at least 75 points to be considered responsive for financial evaluation.

- (I) Detailed evaluation criteria which is to be used for evaluation of technical bids is as indicated below as Appendix-EC.
- (II) The Project Management Consultant should carryout self-evaluation based on the evaluation criteria at Appendix-EC. While submitting the self-evaluation along with bid, Project Management Consultant shall make references to the documents which has been relied upon in his self-evaluation.
- (III) The single currency for price conversion is INR. In case the financial figures and values of services provided are in foreign currency current market exchange rate (*The conversion rate of USD into Rupees shall be the daily representative exchange rates published by the Reserve Bank of India for the relevant date. Where relevant date should be as on the date 7 (seven) days prior to the Bid Due Date*) will be applied for the purpose of conversion of amount in foreign currency into Indian Rupees.
- (IV) The weightage given to technical proposal is 80%.

The weightage given to financial proposal is 20%.

---

Consultancy Services of PMC for supervision of balance Construction of Six-laning of Barwa Adda Panagarh section of NH-2 from km 398.240 to km 521.120 including Panagarh bypass in the states of Jharkhand and West Bengal under NHDP Phase V on DBFOT basis (Project)

11. Commencement of Assignment: The firm shall begin carrying out the services within one month of signing of the Consultancy Agreement.

**Remarks:** Based on experience and the Consulting Industry's Capacity, Project specific requirement etc., The Employer may modify the above criteria for Selection of PMC.

## Appendix-EC

### 1. Evaluation Criteria for Assessment of Experience of the Firm.

S. No.	Description	Max. Marks	Reference/Details of projects Claimed for self-assessment	Marks self-assessed by the bidder
1	Average Annual Turnover (last 3 years) from consultancy business < 2% of Estimated Project Cost – 0 marks 2% of Estimated Project Cost – 1.5 marks Add for additional turnover 0.25 (Zero point two five) marks for every 1% of Estimated Project Cost above 2% of Estimated Project Cost subject to maximum 0.5 marks.	2		
2	Nos. of Highway Professionals with the firm *	10		
2.1	<10	0		
2.2	10-20	8		
2.3	>20 but ≤30	9		
2.4	>30	10		
<p><b>*The professionals who possess degree in Civil Engineering/Transport Planning /Transport Economics/Traffic Management / Geology/ Environment Science or Engineering and 8 years experience in highway/bridge /tunnel with employment in the firm for more than one year. The current Employment Certificate shall be submitted.</b></p>				
3	Experience as Independent Engineer/ Construction Supervision Engineer/ Construction Supervision in Number of Highway Projects of 2/4/6-laning** of length (40% of project length) or more in last 7 years.  1 project – 8 marks Add 1 (one) mark extra for completed assignment of Construction Supervision Engineer/ Independent Engineer and add 0.5 (Zero point five) marks extra for completed assignment of supervision consultancy subject to maximum 2 (Two) marks.	10		

---

Consultancy Services of PMC for supervision of balance Construction of Six-laning of Barwa Adda Panagarh section of NH-2 from km 398.240 to km 521.120 including Panagarh bypass in the states of Jharkhand and West Bengal under NHDP Phase V on DBFOT basis (Project)

S. No.	Description	Max. Marks	Reference/Details of projects Claimed for self-assessment	Marks self-assessed by the bidder
4	Experience in DPR/Feasibility Study cum Preliminary Design Report preparation for Number of Highway Projects of 2/4/6-laning** of length (40% of project length) or more in last 7 years.  1 project – 4 marks Add 0.5 (Zero point five) marks extra for each additional project subject to maximum 1 mark.	5		
5	In hand DPRs of Highway/Bridge/Tunnel Projects ( presently under progress)	10		
5.1	<2	0		
5.2	2-5	5		
5.3	>5	10		
6	Experience in Construction Supervision/DPR/Design Review of Major structures having length of more than 500 meter in last 7 years.  1 project – 2.0 marks Add 0.5 (Zero point five) marks extra for each additional project subject to maximum 1.0 marks	3		
7	Additional requirement in case of specialized projects***	***		

Note 1: Employer's certificate/ certificate from Statutory Auditor should be submitted substantiating the experience/turnover claimed by the firm.

Note 2: \*\* For 4/6 laning projects, experience of 2 lane will be considered with a multiplication factor of 0.4, but only for those 2 lane projects whose cost of consultancy services was more than Rs.3.0 crores.

\*\*\* In case the project includes any specialized nature of work such as tunnels, specialized structures etc. in substantial quantum, this requirement/Marks may be included by suitably adjusting marks of other attributes.

**2. Evaluation Criteria for assessment of experience in use of technology for road inspection**

<b>Evaluation sheet for assessment of experience in use of technology for road inspection</b>				
<b>S. No.</b>	<b>Description</b>	<b>Maximum Points</b>	<b>Reference/ Details of projects Claimed for self-assessment</b>	<b>Marks self-assessed by the bidder</b>
<b>1.</b>	Experience in Network Survey Vehicle (NSV) or better technology for pavement inspection	<b>7</b>		
1.1	Own Equipment/ Equipment on MOU with Associate or on hiring basis	<b>4</b>		
1.2	Experience			
(i)	1-2 projects	1		
(ii)	3-5 projects	2		
(iii)	>5 projects	3		
<b>2.</b>	Experience in Falling Weight Deflectometer (FWD) or better technology for pavement strength measurement	<b>4</b>		
2.1	Own Equipment/ Equipment on MOU with Associate or on hiring basis	<b>2</b>		
2.2	Experience	<b>2</b>		
(i)	1-3 projects	1		
(ii)	>3 projects	2		
<b>3.</b>	Experience in Mobile Bridge inspection Unit or better technology for bridge inspection	<b>5</b>		
3.1	Own Equipment/ Equipment on MOU with Associate or on hiring basis	<b>2</b>		
3.2	Experience	<b>3</b>		
(i)	1-2 projects	1		
(ii)	3-5 projects	2		
(iii)	>5 projects	3		
<b>4.</b>	Experience in Retro reflectometer technology	<b>4</b>		
4.1	Own Equipment/ Equipment on MOU with Associate or on hiring basis	<b>2</b>		
4.2	Execution with owned/ hired Equipment through Associate	<b>2</b>		
(i)	1-3 projects	1		
(ii)	>3 projects	2		
	<b>Total</b>	<b>20</b>		

**Notes:**

- (i) The Consultants owning the equipment shall be required to submit proof of ownership.
- (ii) The experience of the associate firms in use of technology shall also be counted in the evaluation. The experience of firm or associate firm in NSV or equivalent technology, FWD or equivalent technology, MBIU or equivalent technology and Retro reflectometer or equivalent technology shall be supported by experience certificate. The experience of a firm/ associate firm for a private concessionaire/contractor (client) shall be considered provided the experience is duly endorsed by the respective government agency. Any false certification shall attract provisions of clause 1.8, Section-2(Letter of Invitation) read with clause 2.9.1(g) of GCC.
- (iii) In case, Ownership document of equipment of Consultancy/Associate firm is found to be false, i) The Consultancy/Associate firm, as the case may be, shall be put on holiday listing (temporary debarment) for a period of 12 months.

### 3 Evaluation Criteria for assessment of score of Key Staff for adequacy of the Assignment.

#### 3.1 Team Leader cum Senior Highway Engineer

S. No.	Description	Max. Points	Reference/Details of projects Claimed for self-assessment	Marks self-assessed by the bidder
<b>1</b>	<b>General Qualification</b>	<b>25</b>		
i)	Graduate in Civil Engineering	21		
ii)	Post-Graduation in Management/ Construction/ Transportation/Highway Engineering/Structural Engineering or equivalent specialised stream of civil engineering	04		
<b>2</b>	<b>Adequacy for the Project</b>	<b>70</b>		
<b>a)</b>	<b>Professional Experience in Highway Projects:</b>			
i)	Total Professional Experience in handling Highway projects < 12 years -0 12 years -8 marks Add 1 mark extra for each additional year of experience subject to maximum 2 (two) marks.	10		
ii)	Experience as Team Leader or similar capacity in Highway Development Projects(similar configuration (2/4/6 laning**) and above) < 5 years -0 5 years -11 marks Add 1 marks extra for each additional year of experience subject to maximum 4 (four) marks.	15		
iii)	Experience as Team Leader or similar capacity in Highway Development projects (of length 40% of project length or more of similar configuration (2/4/6 laning**) and above) on EPC 1 project -4 marks add 1 mark extra for additional projects subject to maximum 1 (one) mark	5		



S. No.	Description	Max. Points	Reference/Details of projects Claimed for self-assessment	Marks self-assessed by the bidder
b)	Experience as Team Leader or similar capacity of project Preparation including design of major highway Project (of length 40% of project length or more of similar configuration (2/4/6 laning**) and above). < 2 projects -0 2 Projects -11 marks Add 2 marks for each additional project subject to maximum 4 marks.	15		
c)	Experience in position of Team Leader/Project Manager or similar capacity in Construction Supervision/IC involving length 40% of project length or more of similar configuration (2/4/6** laning) and above < 2 projects – 0 2 Projects – 16 marks Add 2 marks extra for each additional project subject to maximum 4 (four) marks	20		
d)	Experience as Team Leader or similar capacity in Operation and Maintenance of Major Highway (of length 40% of project length or more of similar configuration (2/4/6 laning**) and above). 1 project – 4 marks Add 1 mark extra for each additional project subject to maximum 1 (one) mark	5		
3	Employment with the Firm < 1 year -0 1 year – 3 marks Add 0.5 marks for each subsequent year subject to maximum 2 marks	5		
	<b>Total :</b>	<b>100</b>		

**Note:**

(1) Similar Capacity includes the following positions

- i) On behalf of Consultant: Team Leader/ Resident Engineer (Construction Supervision / IE/AE/DPR).

---

Consultancy Services of PMC for supervision of balance Construction of Six-laning of Barwa Adda Panagarh section of NH-2 from km 398.240 to km 521.120 including Panagarh bypass in the states of Jharkhand and West Bengal under NHDP Phase V on DBFOT basis (Project)

- ii) On behalf of Contractor: Project Manager (Construction/Construction Supervision)
  - iii) In Government Organizations: Superintending Engineer (or equivalent) and above
- (2) Only those projects will be considered for evaluation at S. No. 2(b) where the input of the personnel is not < 9 months.
- (3) Only those projects will be considered for evaluation at S. No. 2(c), (d) where the input of the personnel is not < 12 months.
- (4) In case of experience on behalf of Project Management Consultant or Contractor, the experience shall be duly endorsed by the respective Government agency. In case of non-availability of endorsement from Govt. Agency, the experience will not be taken into consideration. However, the key personnel/ bidder will be solely responsible for any fake information/ CV, which may result in debarment.

### 3.2 Resident cum Bridge Engineer

S. No.	Description	Max. Points	Reference/ Details of projects Claimed for self-assessment	Marks self-assessed by the bidder
<b>1</b>	<b>General Qualification</b>	<b>25</b>		
i)	Graduate in Civil Engineering	21		
ii)	Post-Graduation in Transportation/ Highway Engineering/ Structural Engineering/ Geotechnical Engineering	04		
<b>2</b>	<b>Adequacy for the Project</b>	<b>70</b>		
	<b>Professional Experience</b>			
i)	Total Professional Experience in handling Highway/Bridge projects < 12 years -0 12 years - 15 marks Add 1 mark extra for each additional year of experience subject to maximum 5 (five) marks.	20		
ii)	Experience as Resident Engineer/Project Director/Project Manager/Superintending Engineer or equivalent/Executive Engineer or equivalent on construction works/Construction Supervision Engineer/Independent Engineer Projects of Bridges/ROB/Flyover/Interchanges/any other such structures (similar configuration (2/4/6 laning*) and above). < 5 years -0; 5 years -15 marks Add 1 marks extra for each additional year of experience subject to maximum 5 (five) marks.	20		
iii)	Experience in similar capacity in handling major Highway Bridges/ROB/Flyover/Interchanges/any other such structures (of length 40% of project length or more of	25		

Consultancy Services of PMC for supervision of balance Construction of Six-laning of Barwa Adda Panagarh section of NH-2 from km 398.240 to km 521.120 including Panagarh bypass in the states of Jharkhand and West Bengal under NHDP Phase V on DBFOT basis (Project)

S. No.	Description	Max. Points	Reference/ Details of projects Claimed for self-assessment	Marks self-assessed by the bidder
	similar configuration (2/4/6 laning**) and above) < 2 nos. -0 2 nos. -19 marks Add three marks extra for each additional project subject to maximum 6 (Six) marks.			
iv)	Experience in similar capacity of Highway Project of Construction/Construction Supervision/IC on EPC Mode of Bridges/ROB/Flyover/Interchanges/any other such structures (of length 40% of project length or more of similar configuration (2/4/6 laning**) and above) 1 Project- 4 marks Add 1 (one) mark extra for each additional project subject to maximum 1 (one) mark	5		
3	Employment with the Firm < 1 year -0 1 year - 3 marks Add 0.5 marks for each subsequent year subject to maximum 2 marks	5		
	<b>Total :</b>	<b>100</b>		

**Note:**

(1) Similar Capacity includes the following positions

- i) On behalf of Consultant: Resident / Bridge Engineer
- ii) On behalf of Contractor: Resident Engineer/ Bridge Engineer / Project Manager (Bridges)  
(Construction/Construction Supervision)
- iii) In Government Organizations: Executive Engineer (or equivalent) and above

(2) Only those projects (in numbers) will be considered for evaluation above, where the input of the personnel is not < 12 months

---

Consultancy Services of PMC for supervision of balance Construction of Six-laning of Barwa Adda Panagarh section of NH-2 from km 398.240 to km 521.120 including Panagarh bypass in the states of Jharkhand and West Bengal under NHDP Phase V on DBFOT basis (Project)

(3) In case of experience on behalf of Project Management Consultant or Contractor, the experience shall be duly endorsed by the respective Government agency. In case of non-availability of endorsement from Govt. Agency, the experience will not be taken into consideration. However, the key personnel/ bidder will be solely responsible for any fake information/ CV, which may result in debarment.

### 3.3 Bridge/Structural Engineer

S. No.	Description	Max. Points	Reference/Details of projects Claimed for self-assessment	Marks self-assessed by the bidder
<b>1</b>	<b>General Qualification</b>	<b>25</b>		
i)	Graduate in Civil Engineering	21		
ii)	Post-Graduation in Structural Engineering	04		
<b>2</b>	<b>Adequacy for the Project</b>	<b>70</b>		
i)	Total Professional Experience in handling Highway/Bridge projects < 10 years -0 10 years -11 marks Add one mark extra for each additional 2 year subject to maximum 4(four) marks	15		
ii)	Experience in similar capacity in Design/Construction/Construction Supervision of Bridges/ROB/Flyover/Interchanges/any other such structures (similar configuration (2/4/6 laning**) and above) < 5 years -0; 5 years -15 marks Add 1 (one) mark extra for each additional completed year of experience subject to maximum 5 (five) marks	20		
iii)	Experience in similar capacity in supervision of Major Highway Bridges/ROB/Flyover/ Interchanges/ any other structures < 2 Bridges -0 02 Bridge -15 marks	20		

Consultancy Services of PMC for supervision of balance Construction of Six-laning of Barwa Adda Panagarh section of NH-2 from km 398.240 to km 521.120 including Panagarh bypass in the states of Jharkhand and West Bengal under NHDP Phase V on DBFOT basis (Project)

S. No.	Description	Max. Points	Reference/Details of projects Claimed for self-assessment	Marks self-assessed by the bidder
	Add 2.5 mark extra for each additional bridge subject to maximum 5 marks			
iv)	Experience in similar capacity in supervision of Rehabilitation and repair of Major Bridges/ROB/Flyover/ Interchanges/ any other structures  < 2 nos. – 0 2 nos. -8 marks > 3 nos.- 10	10		
v)	Experience in similar capacity of modern bridge construction technology viz., Precast Segmental, Balanced Cantilever Construction, Extra dosed Bridge, Full Span Launching, Incremental Launching.  Experience in 1 project – 4 marks More than one project – 5 marks	5		
<b>3</b>	<b>Employment with the Firm</b>  < 1 year -0 1 year -3 marks  Add 0.5 marks for each subsequent year subject to maximum 2 marks	<b>5</b>		
	<b>Total :</b>	<b>100</b>		

**Note:**

- (1) Similar Capacity includes the following positions
  - i) On behalf of Consultant/Contractor: Bridge Engineer/Project Manager (Bridges)
  - ii) On behalf of Government: Executive Engineer
- (2) Only those projects (in numbers) will be considered for evaluation above, where the input of the personnel is not < 12 months
- (3) In case of experience on behalf of Project Management Consultant or Contractor, the experience shall be duly endorsed by the respective Government agency. In case of non-availability of endorsement from Govt. Agency, the experience will not be taken into consideration. However, the key personnel/ bidder will be solely responsible for any fake information/ CV, which may result in debarment.

---

Consultancy Services of PMC for supervision of balance Construction of Six-laning of Barwa Adda Panagarh section of NH-2 from km 398.240 to km 521.120 including Panagarh bypass in the states of Jharkhand and West Bengal under NHDP Phase V on DBFOT basis (Project)

### 3.4 Highway Engineer

S. No.	Description	Max. Points	Reference/Details of projects Claimed for self-assessment	Marks self-assessed by the bidder
<b>1</b>	<b>General Qualification</b>	<b>25</b>		
I)	Graduate in Civil Engineering	21		
II)	Post-Graduation in Transportation/Highway Engineering/Pavement engineering or equivalent	04		
<b>2</b>	<b>Adequacy for the Project</b>	<b>70</b>		
	<b>Professional Experience</b>			
i)	Total Professional Experience of Pavement Design/Construction and Maintenance of Highways/Roads/Air Field Runway < 10 years -0 10 years -15 marks Add one mark extra for each additional year of experience subject to maximum 5 (five) marks.	20		
ii)	Experience in Similar capacity in Construction/Construction Supervision of 2/4/6laning** of major Highway Projects (similar configuration (2/4/6 laning**) and above) < 5 years -0; 5 years -15 marks Add one mark extra for each additional year of experience subject to maximum 5 (five) marks.	20		

S. No.	Description	Max. Points	Reference/Details of projects Claimed for self-assessment	Marks self-assessed by the bidder
iii)	Experience in similar capacity as Pavement/Geotechnical Engineer in construction/ construction supervision of Major Highway projects (of length 40% of project length or more of similar configuration (2/4/6 laning**) and above)  < 2 nos. -0 2 nos. -20 marks Add 2.5 marks extra for each additional project subject to maximum 5 marks.	25		
iv)	Experience in similar capacity on EPC Projects (of length 40% of project length or more of similar configuration (2/4/6 laning**) and above)  1 Project- 4 marks Add 1 (one) mark extra for each additional project subject to maximum 1 (one) mark	5		
<b>3</b>	Employment with the Firm  < 1 year -0 1 year – 3 marks Add 0.5 marks for each subsequent year subject to maximum 2 marks	<b>5</b>		
	<b>Total :</b>	<b>100</b>		

**Note:**

- (1) Similar Capacity includes the following positions
  - i) On behalf of Consultant/Contractor: Pavement Specialist/ Pavement Engineer/Pavement Expert / Highway Engineer
  - ii) On behalf of Government: Executive Engineer
- (2) Only those projects (in numbers) will be considered for evaluation above, where the input of the personnel is not < 6 months
- (3) In case of experience on behalf of Project Management Consultant or Contractor, the experience shall be duly endorsed by the respective Government agency. In case of non-availability of endorsement from Govt. Agency, the experience will not be taken into consideration. However,

---

Consultancy Services of PMC for supervision of balance Construction of Six-laning of Barwa Adda Panagarh section of NH-2 from km 398.240 to km 521.120 including Panagarh bypass in the states of Jharkhand and West Bengal under NHDP Phase V on DBFOT basis (Project)



the key personnel/ bidder will be solely responsible for any fake information/ CV, which may result in debarment.

### 3.5 Senior Quality/Material Expert

S. No.	Description	Max. Points	Reference/Details of projects Claimed for self-assessment	Marks selfassessed by the bidder
<b>1</b>	<b>General Qualification</b>	<b>25</b>		
	I) Graduate in Civil Engineering	21		
	II) Post Graduation in Geotechnical Engineering/ Foundation Engineering/ Soil Mechanics/ Rock Mechanics	04		
<b>2</b>	<b>Adequacy for the Project</b>	<b>70</b>		
	<b>Professional Experience</b>			
i)	Total Professional Experience in handling Highway/Bridge projects < 10 years - 0 10 years - 11 Add one mark extra for each additional year of experience subject to maximum 4 (four) marks.	15		
ii)	Experience in similar capacity in Construction/ Construction Supervision of major Highway Projects ((similar configuration (2/4/6 laning**) and above)) < 5 years -0; 5 years -19 Add 2.0 (two) marks extra for each additional year of experience subject to maximum 6 (Six) marks.	25		
iii)	Experience in similar capacity in handling Similar Highway projects (of length 40% of project length or more of similar configuration (2/4/6 laning**) and above) < 2 nos. -0 2 nos. - 25 Add 2.5 marks extra for each additional project subject to maximum 5 (five) marks.	30		

Consultancy Services of PMC for supervision of balance Construction of Six-laning of Barwa Adda Panagarh section of NH-2 from km 398.240 to km 521.120 including Panagarh bypass in the states of Jharkhand and West Bengal under NHDP Phase V on DBFOT basis (Project)

<b>3</b>	Employment with the Firm < 1 year – 0 1 year – 3 Add 0.5 marks for each subsequent year subject to maximum 2 marks	<b>5</b>		
	<b>Total :</b>	<b>100</b>		

**Note:**

- (1) Similar Capacity includes the following positions
  - i) On behalf of Consultant/Contractor: Quality Expert/ Material Engineer/Material Expert/ Quality Engineer/ Geo-Technical Expert.
  - ii) On behalf of Government: Executive Engineer
- (2) Only those projects (in numbers) will be considered for evaluation above, where the input of the personnel is not < 12 months
- (3) In case of experience on behalf of Project Management Consultant or Contractor, the experience shall be duly endorsed by the respective Government agency. In case of non-availability of endorsement from Govt. Agency, the experience will not be taken into consideration. However, the key personnel/ bidder will be solely responsible for any fake information/ CV, which may result in debarment.

**3.6 Road Safety Expert**

<b>S. No.</b>	<b>Description</b>	<b>Max. Points</b>	<b>Reference/ Details of projects Claimed for self-assessment</b>	<b>Marks self-assessed by the bidder</b>
<b>1</b>	<b>General Qualification</b>	<b>25</b>		
I)	Graduate in Civil Engineering	21		
II)	Post-Graduation in Traffic/ Transportation/ Safety Engineering or equivalent	04		

<b>2</b>	<b>Adequacy for the Project</b>	<b>70</b>		
	<b>Professional Experience</b>			
i)	Total Professional Experience in handling Highway/Bridge projects < 10 years -0 10 years -11 marks Add one mark extra for each additional year of experience subject to maximum 4 (four) marks.	15		
ii)	Experience in similar capacity in Road Safety works on Major Highway Project (similar configuration (2/4/6 laning**) and above). < 5 years -0 5 years -11 marks Add one mark extra for each additional year of experience subject to maximum 4 (four) marks.	15		
iii)	Experience in similar capacity in Road Safety Audits of 2/4/6laning** Highway projects at different stages including at least one at design stage < 2 nos. -0 2 nos. -15 marks Add 2.5 marks extra for each additional project subject to maximum 5 marks.	20		
iv)	Experience in similar capacity in identification and improvement of black spots on Major Highway Project (similar configuration (2/4/6 laning**) and above) < 2 nos. -0 2 nos. -8 marks Add 2 marks extra for each additional improvement of black spots subject to maximum 2 marks.	10		
v)	Experience in similar capacity of preparing Road Safety Management Plans for Inter Urban Highway 1 project -4 marks 2 or more -5 marks	5		

vi)	Experience in similar capacity in field of Road Safety Management Plan 1 project -4 marks 2 or more -5 marks	5		
3	Employment with the Firm <1 year- 0 1 year – 3 marks Add 0.5 marks for each subsequent year subject to maximum 2 marks	5		
	<b>Total :</b>	<b>100</b>		

**Note:**

- (1) Similar Capacity includes the following positions
- i) On behalf of Consultant/Contractor: Road Safety Expert
  - ii) In Government Organizations: Executive Engineer (or equivalent) and above
- (2) Only those projects (in numbers) will be considered for evaluation above, where the input of the personnel is not < 6 months

**3.6 Quantity Surveyor / Planning Engineer**

S. No.	Description	Max. Points	Reference/ Details of projects Claimed for self-assessment	Marks self-assessed by the bidder
<b>1</b>	<b>General Qualification</b>	<b>25</b>		
I)	Graduate in Civil Engineering	21		
II)	Post-Graduation in Traffic/ Transportation/ Safety Engineering or equivalent	04		

<b>2</b>	<b>Adequacy for the Project</b>	<b>70</b>		
	<b>Professional Experience</b>			
i)	Total Professional Experience in handling Highway/Bridge projects < 10 years -0 10 years -11 marks Add one mark extra for each additional year of experience subject to maximum 4 (four) marks.	15		
ii)	Experience in similar capacity in Road Safety works on Major Highway Project (similar configuration (2/4/6 laning**) and above). < 5 years -0 5 years -11 marks Add one mark extra for each additional year of experience subject to maximum 4 (four) marks.	15		
iii)	Experience in similar capacity in Road Safety Audits of 2/4/6laning** Highway projects at different stages including at least one at design stage < 2 nos. -0 2 nos. -15 marks Add 2.5 marks extra for each additional project subject to maximum 5 marks.	20		
iv)	Experience in similar capacity in identification and improvement of black spots on Major Highway Project (similar configuration (2/4/6 laning**) and above) < 2 nos. -0 2 nos. -8 marks Add 2 marks extra for each additional improvement of black spots subject to maximum 2 marks.	10		
v)	Experience in similar capacity of preparing Road Safety Management Plans for Inter Urban Highway 3 project -4 marks 4 or more -5 marks	5		

vi)	Experience in similar capacity in field of Road Safety Management Plan 3 project -4 marks 4 or more -5 marks	5		
3	Employment with the Firm <1 year- 0 1 year – 3 marks Add 0.5 marks for each subsequent year subject to maximum 2 marks	5		
	<b>Total :</b>	<b>100</b>		

**Note:**

- (3) Similar Capacity includes the following positions
- iii) On behalf of Consultant/Contractor: Road Safety Expert
  - iv) In Government Organizations: Executive Engineer (or equivalent) and above
- (4) Only those projects (in numbers) will be considered for evaluation above, where the input of the personnel is not < 6 months

**3.6 Survey Engineer**

S. No.	Description	Max. Points	Reference/ Details of projects Claimed for self-assessment	Marks self-assessed by the bidder
<b>1</b>	<b>General Qualification</b>	<b>25</b>		
I)	Graduate in Civil Engineering	21		
II)	Post-Graduation in Traffic/ Transportation/ Safety Engineering or equivalent	04		
<b>2</b>	<b>Adequacy for the Project</b>	<b>70</b>		
	<b>Professional Experience</b>			
i)	Total Professional Experience in handling Highway/Bridge projects < 10 years -0 10 years -11 marks Add one mark extra for each additional year of experience subject to maximum 4 (four) marks.	15		

S. No.	Description	Max. Points	Reference/ Details of projects Claimed for self-assessment	Marks self-assessed by the bidder
ii)	<p>Experience in similar capacity in Road Safety works on Major Highway Project (similar configuration (2/4/6 laning**) and above). &lt; 5 years -0</p> <p>5 years -11 marks</p> <p>Add one mark extra for each additional year of experience subject to maximum 4 (four) marks.</p>	15		
iii)	<p>Experience in similar capacity in Road Safety Audits of 2/4/6laning** Highway projects at different stages including at least one at design stage</p> <p>&lt; 2 nos. -0</p> <p>2 nos. -15 marks</p> <p>Add 2.5 marks extra for each additional project subject to maximum 5 marks.</p>	20		
iv)	<p>Experience in similar capacity in identification and improvement of black spots on Major Highway Project (similar configuration (2/4/6 laning**) and above)</p> <p>&lt; 2 nos. -0</p> <p>2 nos. -8 marks</p> <p>Add 2 marks extra for each additional improvement of black spots subject to maximum 2 marks.</p>	10		
v)	<p>Experience in similar capacity of preparing Road Safety Management Plans for Inter Urban Highway</p> <p>5 project -4 marks</p> <p>6 or more -5 marks</p>	5		

vi)	Experience in similar capacity in field of Road Safety Management Plan 5 project -4 marks 6 or more -5 marks	5		
3	Employment with the Firm <1 year- 0 1 year – 3 marks Add 0.5 marks for each subsequent year subject to maximum 2 marks	5		
	<b>Total :</b>	<b>100</b>		

**Note:**

- (5) Similar Capacity includes the following positions
- v) On behalf of Consultant/Contractor: Road Safety Expert
  - vi) In Government Organizations: Executive Engineer (or equivalent) and above
- (6) Only those projects (in numbers) will be considered for evaluation above, where the input of the personnel is not < 6 months

**3.7 Deleted**

**3.8 Deleted**

**3.9 Deleted**

**3.10 Deleted**

**3.11 Deleted**

**3.12 Deleted**

**3.13 Deleted**

**3.14 Deleted**

**3.15 Deleted**

Note: applicable to all key personnel:

1. If a key personnel has worked in next lower category to the similar capacity, the marks allotted to key personnel in the category 'experience in similar capacity' shall be reduced To two thirds of marks in this category. This shall be applicable for evaluation of all key personnel.



2. \*\* Similar projects means 2/4/6 lane as applicable for the project for which RFP is invited. Experience of 4/6 lane shall be considered interchangeably for 4/6 laning projects. For 4/6 laning projects, experience of 2 lane will be considered with a multiplication factor of 0.4.

### SECTION 3: FORMATS FOR SUBMISSION OF FIRMS CREDENTIALS

The proposal should contain the following information in enclosed format attached at Appendix A.

- Year of Establishment of Firm
- Average annual turnover (last three years)

**Note:** The Firm shall submit Certificate of Incorporation and audited balance sheet for the last three years (i.e. FY 2018-2019, FY 2019-2020 and FY 2020-21). For claiming experience of Highway projects, completion certificate from employer should be enclosed. The proposal should also contain the details of the key personnel viz. their name, qualification, expertise area, experience and years of association with the firm.

## Appendix A

The following information related to the firm should be provided in the proposal.

- i. Name of the package applied for:-
- ii. Year of establishment of firm\*

Consultant	Year of Establishment	Country	Type of Organization			
			Individual	Partnership	Corporation	Other
Individual / Lead Partner (of JV)/ Minor Partner of JV/Associate						

NOTE:- Year of Establishment of Lead Partner of JV shall be considered.

\*Copy of Certificate of incorporation shall be submitted.

- iii. Office/ Business Address/Telephone nos. /Cable Address. iv. Narrative description of firm (Not more than 2 sheets)
- v. Name of two (2) principals who may be contacted with title and telephone number/fax number/e-mail.
- vi. Financial Statement of the last three years. \*\*

Sl. No.	Particular	2018-19	2019-20	2020-21
i.	Annual turnover from Consulting business			
ii.	Total Assets			
iii.	Current Assets			

Balance Sheet/ Auditor Certificate of last 3 years i.e. FY 2018-2019, FY 2019-2020 and FY 202021 shall be submitted as evidence of Annual Turnover.

- \*\* a) The amount shall be stated in INR. The conversion rate of USD into Rupees shall be the daily representative exchange rates published by the Reserve Bank of India for the relevant date. Where relevant date should be as on the date 7 (seven) days prior to the Bid Due Date.
- b) The currency conversion rate for the respective years shall be mentioned for other International currencies.
- vii. Experience as Construction Supervision Engineer/Independent Consultant/Construction supervision of Highway projects, separately for PPP and non-PPP Projects during the last 7 years. \*\*\*

---

Consultancy Services of PMC for supervision of balance Construction of Six-laning of Barwa Adda Panagarh section of NH-2 from km 398.240 to km 521.120 including Panagarh bypass in the states of Jharkhand and West Bengal under NHDP Phase V on DBFOT basis (Project)

S. No.	Projects Name / Year Sole Consultant / Prime Consultant of JV / minor Authority's Engineer of JV / as associate consultant	Type of Services rendered	Description of Highway Project/ Length (kms)	Client (with complete address, contact person, Telephone Nos. and Fax Nos.)	Total Fee for the Consultancy Assignment (INR)	Fee received by Applicant (in case of JV/ Association)	%age of total fee received by the firm	Approx. Cost of Highway Project	Period
1	2	3	4	5	6	7	8	9	10
		A. Completed / Substantially completed projects: 1. 2. 3. B. Projects in progress: 1. 2. 3.							

- viii. Experience in DPR/ Feasibility Study cum Preliminary Design Report preparation of 2/4/6 laning / Bridge Highway Projects separately for the PPP and non-PPP projects during the last 7 years. \*\*\*

S No	Projects Name / Year	Type of Services Rendered	Length of Project (kms)	Client (with Complete address, contact person, telephone Nos. and Fax Nos.)	Total Fee for the Consultancy Assignment (INR)	Fee received by Applicant (in case of JV/Association)	%age of total fee received by the firm	Period
	Sole Consultant/ Prime Consultant of JV / minor Project Management Consultant of JV/ /as							

Consultancy Services of PMC for supervision of balance Construction of Six-laning of Barwa Adda Panagarh section of NH-2 from km 398.240 to km 521.120 including Panagarh bypass in the states of Jharkhand and West Bengal under NHDP Phase V on DBFOT basis (Project)

	associate consultant							
1	2	3	4	5	6	7	8	9

- \*\*\*a) 2/4/6 lane/Bridge work as applicable for the project for which RFP is invited. Experience of 4/6 lane shall be considered interchangeably for 4/6 laning projects. For 4/6 lane projects, experience of 2 lane will be considered with a multiplication factor of 0.4, but only for those 2-lane projects whose cost of consultancy services was more than Rs.3.0 crores. For standalone bridge projects, experience in bridge work (either standalone project or as a part of road project) only be considered.
- b) Only those projects, to be included in the table which are Highways Projects and for which clients certificates from the concerned Government agencies are enclosed with the proposal.
- c) The details of bridges having length more than 200m (500m in case the project consist of bridges of length more than 500m) in the listed projects is to be specifically mentioned.
- d) The weightage given for experience of a firm would depend on the role of the firm in the respective assignments. The firm's experience would get full credit if it was the sole firm in the respective assignment. If the applicant firm has completed projects as JV with some other firms, weightage shall be given as per the JV share\*\*\*. However if the applicant firm has executed the project as associate with some other firms, 25% weightage shall be given to the applicant firm for the projects completed under such association
- e) For weightage of experience in any past Consultancy assignment, experience certificate from the client shall be submitted. In absence of clear demarcation of JV share in client certificate, the weightage will be treated as 60 % for lead partner and 40% for minor partner. Annual turnover duly certified by Chartered Accountant shall be accepted. In case of non-availability of such documents no weightage of turnover/experience will be considered.
- (ix) Assignments on hand including those for which the Letter of Acceptance from the clients received as on 7 days prior to due date for submission of proposals: The details shall be given in the following format.

S. No	Name of Assignment	Client	Role of the firm		Date of		Team Members provided by the firm
-------	--------------------	--------	------------------	--	---------	--	-----------------------------------

Consultancy Services of PMC for supervision of balance Construction of Six-laning of Barwa Adda Panagarh section of NH-2 from km 398.240 to km 521.120 including Panagarh bypass in the states of Jharkhand and West Bengal under NHDP Phase V on DBFOT basis (Project)

			Sole, Lead/ Other in JV or sub- consultant	Date of letter of Acceptance	Agreement if signed	Present status of Assignment	Name	DOB	Position
							(8)	(9)	(10)
(1)	(2)	(3)	(4)	(5)	(6)	(7)	(8)	(9)	(10)

Key Personnel	Number of key personnel employed		
	Sole Applicant (Lead Member in case of JV)	JV (1)	
Team Leader cum Senior Highway Engineer			
Resident cum Highway Engineer			
Bridge/Structural Engineer			
Senior Pavement Specialist			
Senior Quality cum Material Expert			
Road Safety Expert			

#### SECTION 4: FORMAT FOR SUBMISSION OF TECHNICAL PROPOSAL

<b>Appendix B-1</b>	Technical proposal submission form.
<b>Appendix B-2</b>	Site Appreciation
<b>Appendix B-3</b>	Approach paper on methodology for performing the assignment
<b>Appendix B-4</b>	Facility for field investigation and testing
<b>Appendix B-5</b>	Composition of the Team and Task(s) of each Team member
<b>Appendix B-6</b>	Curriculum vitae of proposed Professional staff.
<b>Appendix B-7</b>	Time schedule for deployment of Professional staff
<b>Appendix B-8</b>	Activity (works) schedule.
<b>Appendix B-9</b>	Affidavit – Correctness of Experience claimed by the Firms
<b>Appendix B-10</b>	Deleted
<b>Appendix B-11</b>	Determination of Technical Capacity

**APPENDIX B-1-Technical proposal submission form.**

FROM (Name of Firm)

To: (Name and Address of Client)

---

---

---

---

---

---

---

---

Ladies/Gentlemen:

**Subject:** Submission of Technical and Financial Proposal for engagement as Project Management Consultant for the DBFOT work.

We, the undersigned, offer to provide the consulting services for the above in accordance with your Request for Proposal dated (Date), and our Proposal. We are hereby submitting our Proposal, which includes this Technical Proposal and a Financial Proposal sealed under a separate envelope for the above mentioned work.

My/Our registration No. on Infracon is ..... And my/our Infracon Team ID is .....

Our Proposal is binding upon us. We understand you are not bound to accept any Proposal you receive

We remain,

Yours sincerely,

Managing Director/Head of the firm/  
Authorised Representative of the firm  
Name of the firm  
Address



## **APPENDIX B-2: SITE APPRECIATION**

Shall give details of site as per actual site visit and data provided in RFP and collected from site supported by photographs to demonstrate that responsible personnel of the Project Management Consultant have actually visited the site and familiarized with the salient details/ complexities and scope of services.

### **APPENDIX B-3: APPROACH PAPER ON METHODOLOGY FOR PERFORMING THE ASSIGNMENT**

The approach and methodology will be detailed precisely under the following topics.

- 1) Methodology for services, surveying, road condition data collection and analysis [not more than 2 pages]
- 2) Key challenges foreseen and proposed solutions in carrying out the assignment [not more than 1page]
- 3) Quality Audit methodology including Quality Assurance Plan [not more than 6 pages]

**APPENDIX B-4 : FACILITY FOR FIELD INVESTIGATION AND TESTING**

1. State whether applicant has in-house (created in house at site)/ outsourced/ not available facility for
  - Surface defects detection and roughness measurement using Network Survey Vehicle
  - Pavement strength measurement using FWD
  - Bridge inspection using Mobile Bridge Inspection Unit
  - Road signs inspection using Retro Reflectometer
2. In-case answer to 1 is available (created in house at site) a list of field investigation and testing equipment is to be attached
3. In case answer to 1 is outsourced/not available – arrangements made or proposed to be made for each of the above field investigations is to be attached
4. For experience in NSV, FWD, MBIU and reflectometer, references need to be provided in the following format:

**REFERENCES**

Relevant Services Carried Which Best Illustrate Qualifications

The following information should be provided in the format below for each reference assignment for which your firm, either individually as a corporate entity or as one of the major companies within a consortium, was legally contracted by the client:

Assignment Name:		Country:
Location within Country:		Professional Staff Provided by your firm:
Name of Client :		No. of Staff :
Address :		No. of Staff Months :
Technology Used:		
Start Date (Month / Year)	Completion Date (Month / Year)	Approx. Value of Services in INR/current USD):
Name of JV/Association Firm(s)if any:		No. of Months of Professional Staff provided by Associated Firm(s)
Status of your Company in the Assignment i.e., Sole/Lead Member/Other Member/Associate		
Narrative Description of Project :		
Description of Actual Services Provided by your Company:		

Signature of Authorised Representative  
(Certificate from Employer regarding experience should be furnished)

---

Consultancy Services of PMC for supervision of balance Construction of Six-laning of Barwa Adda Panagarh section of NH-2 from km 398.240 to km 521.120 including Panagarh bypass in the states of Jharkhand and West Bengal under NHDP Phase V on DBFOT basis (Project)

**APPENDIX B-5: COMPOSITION OF THE TEAM PERSONNEL, AND TASK(S) OF EACH TEAM MEMBER**

2. Technical/Managerial Staff

<b>Sl. No.</b>	<b>Name</b>	<b>Position</b>	<b>Task</b>
1			
2			
3			
4			
...			
...			

i. Support Staff

<b>Sl. No.</b>	<b>Name</b>	<b>Position</b>	<b>Task</b>
1			
2			
3			
4			
...			
...			

**APPENDIX B-6 : FORMAT OF CURRICULUM VITAE (CV) FOR PROPOSED PROFESSIONAL STAFF**

Proposed Position : .....

Photograph

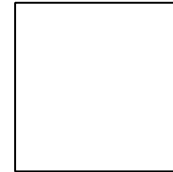

Name of Firm:.....

Name of Staff :.....

Profession

.....

Date of Birth :

Years with Firm/Entity: ..... Nationality:..... Membership of Professional Societies :.....

Detailed Task Assigned : Please attach printout of CV along with all the relevant details uploaded on ITNL/ BAEL portal.

**Certification by the Candidate**

I, the undersigned,(Name and Address) undertake that this CV correctly describes myself, my qualifications and my experience and Employer would be at liberty to debar me if any information given in the CV, in particular the Summary of Qualification & Experience vis-à-vis the requirements as per TOR is found incorrect. I further undertake that I have neither been debarred by Barwa Adda Expressway Limited (BAEL) or any other central/stage government organization nor left any assignment with the consultants engaged by Employer / contracting firm (firm to be supervised now) for any continuing work of Employer without completing my assignment. I will be available for the entire duration of the current project (named.....).If I leave this assignment in the middle of the work, Employer would be at liberty to debar me from taking any assignment in any of the Employer works for an appropriate period of time to be decided by the Employer. I have no objection if my services are extended by the Employer for this work in future.

I further undertake that my CV is being proposed for this project by ----- (the applicant firm) and I have not given consent to any other consultant(s) to propose my CV for any position for this project.

I further undertake that if due to my inability to work on this project due to unavoidable circumstances, due to which consultant's firm is forced to seek replacement. In such unavoidable circumstances, I shall not undertake any employment in Employer projects during the period of assignment of this project and Employer shall consider my CV invalid till such time.

I undertake that I have no objection in uploading/hosting of my credentials by Employer in public domain.

For Key Personnel having intermittent inputs, add the following:

---

Consultancy Services of PMC for supervision of balance Construction of Six-laning of Barwa Adda Panagarh section of NH-2 from km 398.240 to km 521.120 including Panagarh bypass in the states of Jharkhand and West Bengal under NHDP Phase V on DBFOT basis (Project)

I further certify that I am associated with the following assignments as on date (as on 7 days prior to due date for submission of proposal) including those for which LOA has been received by the firm and the inputs in these assignments shall not effect the work of the current assignment.

Name of Assignment	Client	Date of LOA	Likely start (Month / Year)	Likely end (Month / Year)	Total input of the person (man-months)

.....  
 (Signature of Key Personnel)

Date

(Day/Month/Year)

The Project Management Consultant should carryout self-evaluation based on the evaluation criteria at Appendix-EC and furnish the same here. While submitting the self-evaluation along with bid, Project Management Consultant shall make references to the documents which have been relied upon in his self-evaluation.

**Certification by the firm**

The undersigned on behalf of ----- ( name of consulting firm) certify that Shri----- (name of proposed personnel) to the best of our knowledge has neither been debarred by Barwa Adda Expressway Limited (BAEL) or any other Central/State Government organization nor left his assignment with any other consulting firm engaged by the Employer /Contracting firm(firm to be supervised now) for the ongoing projects. We understand that if the information about leaving the past assignment is known to the Employer, Employer would be at liberty to remove the personnel from the present assignment and debar him for an appropriate period to be decided by the Employer.

.....Date : ..... (Day/Month/Year)

*[Signature of authorized representative of the Firm]*

- a) Deleted.
- b) Deleted.
- c) Deleted.
- d) Deleted.
- e) Deleted.
- f) Deleted

**APPENDIXB-7: TIME SCHEDULE FOR PROFESSIONAL PERSONNEL**

**A. Activity Schedule**

Sl. No.	Name	Position	Month wise Program(in form of Bar Chart) [1 <sup>st</sup> , 2 <sup>nd</sup> , etc. are months from the start of assignment]												Number of Months
			1st	2nd	3rd	4th	5th	6th	7th	8th	9th	10 <sup>th</sup>	11 <sup>th</sup>	12 <sup>th</sup> and subsequent year	
1															Subtotal(1)
2															Subtotal(2)
3															Subtotal(3)
4															Subtotal(4)
-															-
-															-

**APPENDIXB-8 : ACTIVITY(WORKS)SCHEDULE**

**B. Activity Schedule**

Sr.No.	Item of Activity (Works)	Month wise Program(information of Bar Chart) [1 <sup>st</sup> ,2 <sup>nd</sup> , etc. are months from the start of assignment]											
		1st	2nd	3rd	4th	5th	6th	7th	8th	9th	10 <sup>th</sup>	11 <sup>th</sup>	12 <sup>th</sup>
1	.....												
2	.....												
3	.....												
4	.....												
-	.....												
-	.....												

**C. Completion and Submission of Reports**

Sr. No	Reports :	Programme Date)
1	Monthly reports (Design and Construction)	
2	Quarterly Reports	
3	Various others reports as provided in the Contract Agreement such as Completion Report	



**APPENDIX B-9: AFFIDAVIT FOR CORRECTNESS OF CV OF KEY PERSONNEL AND  
EXPERIENCE CLAIMED BY THE FIRMS**

**(To be submitted on non-judicial Stamp Paper)**

I, the undersigned, on behalf of \_\_\_\_\_ (name of the Project Management Consultant submitting the proposal), do hereby certify that the details furnished in this proposal including CV of key personnel and experience claimed by the firm/firms are true and correct to the best of my knowledge and belief.

**Managing Director/Head of the Firm/  
Authorised Representative of the firm  
Address**

## **APPENDIX B-10**

**Deleted**

**APPENDIX B-11: (Format for Technical Capacity of Bidding Firms)  
DETERMINATION OF TECHNICAL CAPACITY OF BIDDING FIRMS**

**(TO BE FILLED BY THE SOLE CONSULTANT)**

**(i) No. of Key Professionals on full time roll:**

Sl. No.	Name of key Professional	Designation	Continuous Employment from (Date)	Nos. of Years with the firm

**Note:** Attach Copy of Form 26AS to certify permanent key professionals.

**(ii) Details of all in-hand DPR projects or DPR projects awarded for NH works:**

Sl. No.	Project Description	Bids for Civil works received or original assignment period + one year lapsed (Yes/No)	Start Date	Scheduled Completion	Whether awarded in Current Financial Year (2021-22) (Yes/ No)	IN case of JV, share of Contract Fee (%)	Technical Capacity utilized after applying JV share as per Note 2	Technical Capacity utilized in current financial year after applying JV share as per Note 2
1	2	3	4	5	6	7	8	9

**Format for undertaking by the firm for DPR projects:**

The undersigned on behalf of \_\_\_\_\_ (name of consulting firm) certify that the firm do not have any other in-hand/ awarded DPR project other than those listed above.

Date: \_\_\_\_\_ (dd/mm/yyyy)

[Signature of authorized representative of the Firm]

**(iii) Details of all in-hand AE/IE/SC projects or AE/IE/SC awarded for NH works:**

Sl. No.	Project Description	Civil works provisionally completed or original assignment period + one year lapsed (Yes/No)	Start Date	Scheduled Completion	Whether awarded in Current Financial Year (2021-22) (Yes/No)	IN case of JV, share of Contract Fee (%)	Technical Capacity utilized after applying JV share as per Note 2	Technical Capacity utilized in current financial year after applying JV share as per Note 2
1	2	3	4	5	6	7	8	9

**Format for undertaking by the firm for in-hand AE/IE/SC projects:**

The undersigned on behalf of -----(name of consulting firm) certify that the firm do not have any other in-hand/ awarded AE/IE/SC projects other than those listed above.

Date:------(dd/mm/yyyy)

[Signature of authorized representative of the Firm]

**(iv) Deleted**

**(v) Deleted**

**Note:**

**The Consultant shall re- submit the bid capacity details as per above format at the time of opening of Financial Bid.**

**Illustration for Determination of Technical Capacity (Sole)**

(1)	(2)	(3)			(4)			(5)			(6)			(7)		
Average Annual Turnover of firm in last 3 FY (from consultancy works)	No. of Key Professionals on full time rolls (minimum from last one year) with the consultancy firm	Max. no. of projects to be allotted to one particular consultant including ongoing projects at a time			Max. no. of projects in one financial year (cap of 25%)			Total ongoing/ awarded projects (nos.)			Projects awarded in CFY (nos.) out of Col. (5)			Remaining Capacity for new projects (nos.) in CFY <sup>s</sup>		
		Total	DPR	IE/AE/SC	Total	DPR	IE/AE/SC	Total	DPR	IE/AE/SC	Total	DPR	IE/AE/SC	Total	DPR	IE/AE/SC
		3A	3B	3C	4A	4B	4C	5A	5B	5C	6A	6B	6C	7A	7B	7C
10	10	6	6	4	2	2	1	7	4	3	2	1	1	0	0	0

**For Col. 3, Sub Col. A, B & C are to be considered as per circular dated 30.03.2021 For Col. 4, Sub Col. A, B & C are to be considered as per circular dated 30.03.2021 rounded up to nearest integer For Col. 5 & 6, Sub. Col. A = Sub. Col. B + Sub. Col. C Col. 7 to be derived on the basis of minimum of (Col. 3 - Col. 5) & (Col. 4 - Col. 6)**

**Note:** <sup>s</sup> The figures in Col. 7 be rounded off to the nearest integer i.e. in case remaining Bid Capacity comes to 0.5 or more, then it will be considered as 1, in case less than 0.5, then it will be considered as 0 (Zero).

**SECTION 5: FORMAT FOR SUBMISSION OF FINANCIAL PROPOSAL.**

**Appendix C-1** Financial proposal submission form

**Appendix C-2** Summary of costs

**Appendix C-3** Breakdown of costs

**APPENDIX C-1: FINANCIAL PROPOSAL SUBMISSION FORM**

**FROM : (Name of Firm)**

**TO :**

**Barwa Adda Expressway Limited (BAEL),**  
The IL&FS Financial Centre, Plot C-22, G Block,  
Bandra Kurla Complex, Mumbai- 400051

**Subject :**

We, the undersigned, offer to provide the consulting services for the above in accordance with your Request for Proposal dated [Date], and our proposal. Our attached financial proposal is for the sum of [Amount in words and figures]. This amount is exclusive of the local taxes which we have estimated at (Amount in Words and Figures).

Our financial proposal shall be binding upon us upto the expiration of the validity period of the proposal, i.e., [Date].

We undertake that, in competing for (and, if the award is made to us, in executing) the above contract, we will strictly observe the laws against fraud and corruption in force in India namely "Prevention of Corruption Act 1988".

We understand you are not bound to accept any proposal you receive.

We remain, Yours  
sincerely,

**Managing Director/Head of the firm/ Authorised Representative of the firm\***

Name of the firm

Address

**APPENDIX C-2: SUMMARY OF COSTS**

No.	Description	Amount (Rs.)
I	Remuneration for Local Professional Staff	
II	Supporting Staff	
III	Transportation	
IV	Duty Travel to Site	
V	Office Rent	
VI	Office Supplies, Utilities and Communication	
VII	Office Furniture and Equipment	
VIII	Reports and Document Printing	
IX	Road Survey Equipment	
X	Contingencies	
	Sub Total	
	Goods and Services Tax Payable in India	
	Total Costs (Including Tax)	

Note: Payments will be made as per stipulations of the Conditions of Contract.



## APPENDIX C-3: BREAKDOWN OF LOCAL CURRENCY COSTS

### I. REMUNERATION FOR LOCAL PROFESSIONAL STAFF

#### Normal Highway Project

#### For Project with Construction Period of 15 months

No.	Position	No	Assignment Period 18 months		
			Rate (in Rs.)	No. of man-months*	Amount (in Rs.)
<b>Professional Staff</b>					
1.	Team Leader Cum Senior Highway Engineer	1		18	
2.	Resident cum Bridge Engineer	1		18	
3.	Bridge/Structural Engineer	1		15	
4.	Highway Engineer	2		15	
5.	Senior Quality cum Material Expert	2		15	
6.	Road safety Expert	1		15	
7.	Quantity Surveyor / Planning Engineer	2		18	
	Survey Engineer	2		15	
<b>Sub - Total</b>					
<b>Sub-professional</b>					
1.	Highway Design Engineer	0			
2	Bridge/Structure Design Engineer	0			
3	Survey Engineer (1 No.)	0			
4	Assistant Highway Engineer (2 No.)	0			
5	CAD Expert	0			
6	Environmental Engineer	0			
7	Assistant Bridge Engineer (1 No.)	0			
8	Assistant Quality cum Material Engineer (2 No.)	0			
9	Electrical Engineer	0			
10	HTMS/Toll Expert	0			
11	Quantity Surveyor	0			
12.	Horticulture cum Landscaping Expert	0			
<b>Sub Total</b>					
<b>Total</b>					

**\*The man-month against each key personnel/sub - professional shall be same as specified in Enclosure A of TOR.**

## II. Support Staff

No.	Position	Name	Staff Months	Billing Rate (in Rs.)	Amount (in Rs.)
1.	Office Manager	TBN			
2.	Accountant cum Cashier	TBN			
3.	Steno cum Computer Operator	TBN			
4.	Office Boy ( 1 no)	TBN			
				<b>Total :</b>	

**Note:** Billing rates as indicated above shall be increased in accordance of clause 6.2(a) Special Conditions of Contract for the personnel of all categories namely (i) key Personnel; (ii) sub-Professional personnel and (iii) Support staff. The increase as above shall be payable only on the remuneration part of Key Personnel, Sub-Professional Personnel and support staff. However, for evaluation of Bid proposals, the quoted initial rate shall be multiplied by the total time input for each position on this contract, i.e. without considering the increase in the billing rates

## III. Transportation (Fixed rate on rental basis)

The vehicles provided by the Consultants shall include the cost for rental, drivers, operation, maintenance, repairs, insurance, etc. for all complete approx. 3000km/month run

Sr. No	Description of Vehicles	Qty. (No. of vehicle-month)		Total	Rate/ Vehicle-Month	Amount (in Rs.)
		During Construction Period	During DLP			
1	Innova / Scorpio or equivalent (not more than 3 years old)	18	NA			
2	Bolero or equivalent (not more than 3 years old)	15	NA			
	<b>Total</b>					

**IV. Duty Travel to Site (Fixed Costs) (For all Lengths of projects) :**  
**Professional and Sub-Professional Staff**

Trips	Number of Trips	Rate* (in Rs.)	Amount (in Rs.)
Site to BAEL HQ for Key Professionals	10 round trips (by air economy class)		
Site to Regional Office for Key Professionals	10 round trips ( by air-economy class/ train first AC/ Deluxe AC Bus)		

\* Rate quoted includes Hotel charges, travel cost etc. complete.

**V. Office Rent (Fixed Costs)-**

The rent cost includes electricity and water charges, maintenance, Cleaning, repairs, etc. complete.

Nos. of Months	Rate/month (in Rs.)	Amount (in Rs.)
18		

The rent cost includes electricity and water charges, maintenance, cleaning, repairs, etc. complete.

**VI. Office Supplies, Utilities and Communication (Fixed Costs)**

No	Item	Months	Monthly Rate (in Rs.)	Amount (in Rs.)
1.	Office Supplies	18		
2.	Drafting Supplies	18		
3.	Computer Running Costs	18		
4.	Domestic and International Communication	18		

**VII. Office Furniture and Equipment (Rental)**

The cost shall include rental charges towards all such furniture and equipment as required for proper functioning of office. Office furniture shall include executive tables, chairs, visitor chairs, steel almirahs, computer furniture, conference table etc. Office equipment shall include as a minimum of telephone (2 external & 10 internal lines), photocopier (15ppm, 12000 copies per month with A3 & A4 input) fax machine, PCs(5 No., Intel Core 2 Duo E8300, 19" colour TFT, Cache-6MB, RAM-2 GB, HDD-250 GB, DVD Writer, Key board, optical scroll mouse, MS-Windows Vista Business, pre-loaded anti-virus etc.), laser printers (2 no., 14 ppm, 266 MHZ, 5000 pages per month, 600x600 dpi or better etc., Engineering Plan printer (1 no.), binding machine (1 no.), plotter A0 size, overhead projector, AC (4 no., 1.5 Ton), Water Coolers (as required) etc.

<b>Nos. of Months</b>	<b>Rate/month (in Rs.)</b>	<b>Amount (in Rs.)</b>
18		

**VIII. Reports and Document Printing**

<b>No.</b>	<b>Description</b>	<b>No. of Reports</b>	<b>No. of Copies per Report</b>	<b>Total Nos. of copies</b>	<b>Rate per Copy (in Rs.)</b>	<b>Amount (in Rs.)</b>
<b>1</b>	Monthly reports	15	1	15		
<b>2</b>	Half yearly Reports	3	1	3		
<b>3</b>	Various others reports as provided in the Contract Agreement such as Completion Report	Lump-sum				
	<b>Total</b>					

**IX. Deleted**

**X. Deleted**

## **SECTION 6: TERMS OF REFERENCE FOR PROJECT MANAGEMENT CONSULTANT**

**[Note: The term “Agreement” and clauses thereof refer to the EPC Agreement dated----- entered between Employer and -----(the Contractor) for the work of ..... from km---- to ---- of NH No.----- in the State of ----- on Engineering, Procurement and Construction (EPC) basis].**

### **1. Scope**

1.1 These Terms of Reference (the “**TOR**”) for the Project Management Consultant are being specified pursuant to the EPC Agreement dated..... (the “**Agreement**”), which has been entered into between the Employer and ..... (the “**Contractor**”) for [Two/Four Laning] of the \*\*\*\* section (km \*\* to km\*\*) of National Highway No. \*\* in the State of \*\*\* on Engineering, Procurement, Construction (EPC) basis, and a copy of which is annexed hereto and marked as Annex-A to form part of this TOR.

1.2 The TOR shall apply to construction and maintenance of the Project Highway.

### **2 Definitions and interpretation**

2.1 The words and expressions beginning with or in capital letters and not defined herein but defined in the Agreement shall have, unless repugnant to the context, the meaning respectively assigned to them in the Agreement.

2.2 References to Articles, Clauses and Schedules in this TOR shall, except where the context otherwise requires, be deemed to be reference to the Articles, Clauses and Schedules of the Agreement, and references to Paragraphs shall be deemed to be references to Paragraphs of this TOR.

2.3 The rules of interpretation stated in Clauses 1.2, 1.3 and 1.4 of the Agreement shall apply, *mutatis mutandis*, to this TOR.

### **3 General**

3.1 The Project Management Consultant shall discharge its duties in a fair, impartial and efficient manner, consistent with the highest standards of professional integrity and Good Industry Practice.

3.2 The Project Management Consultant shall perform the duties and exercise the authority in accordance with the provisions of this Agreement, but subject to obtaining prior written approval of the Employer before determining.

(a) any Time Extension.

(b) Any additional cost to be paid by the Employer to the Contractor;

(c) The Termination Payment; or

- (d) Any other matter which is not specified in (a), (b) or (c) above and which creates an obligation or liability on either Party for a sum exceeding Rs. 5,000,000 (Rs. Fifty lakh.)
- 3.3 The Project Management Consultant shall submit regular periodic reports, once every month, to the Employer in respect of its duties and functions under this Agreement. Such reports shall be submitted by the Project Management Consultant within 10 (ten) days of the beginning of every month.
- 3.4 The Project Management Consultant shall inform the Contractor of any delegation of its duties and responsibilities to its suitably qualified and experienced personnel; provided, however, that it shall not delegate the authority to refer any matter for the Employer's prior approval in accordance with the provisions of EPC Agreement.
- 3.5 The Project Management Consultant shall aid and advise the Employer on any proposal for Change of Scope under Article 13.
- 3.6 In the event of any disagreement between the Parties regarding the meaning, scope and nature of Good Industry Practice, as set forth in any provision of the Agreement, the Project Management Consultant shall specify such meaning, scope and nature by issuing a reasoned written statement relying on good industry practice and authentic literature.

#### **4. Role and responsibility of Officers of the Employer**

The officer in-charge of the Consultant is responsible for the overall supervision and monitoring of the execution of project as the representative of the owner of the project. The Project Management Consultant is appointed to assist the Employer for carrying out the functions as detailed under the EPC Agreement. As such, an officer of the Employer is vested with all such powers and responsibilities as are enjoined upon the Project Management Consultant and is fully competent to issue any instructions for proper monitoring and supervision of the project, either by himself or through the Project Management Consultant. Instructions issued by the concerned officer of the Employer shall have the same effect as that of the Project Management Consultant in terms of this Agreement. Wherever such concerned officer issues any instructions or notice to the Contractor, he shall endorse a copy thereof to the Project Management Consultant.

#### **5 Construction Period**

- 5.1 During the Construction Period, the Project Management Consultant shall review and approve the Drawings furnished by the Contractor along with supporting data, including the geo-technical and hydrological investigations, characteristics of materials from borrow areas and quarry sites, topographical surveys, and the recommendations of the Safety Consultant in accordance with the provisions of the EPC Agreement. The Project Management Consultant shall complete such review and approve and send its observations to the Employer and the Contractor within 15 (fifteen) days of receipt of such Drawings; provided, however that in case of a Major Bridge or Structure, the aforesaid period of 15 (fifteen) days may be extended upto 30 (thirty) days. All the

drawings shall be sent by the Consultant to IE/NHAI and got it approved. Post approval the same shall be sent to Contractor for execution. In particular, such comments shall specify the conformity or otherwise of such Drawings with the Scope of the Project and Specifications and Standards.

- 5.2 The Project Management Consultant shall review and approve any revised Drawings sent to them by the Contractor in consultation with Employer/IE/NHAI and furnish its comments within 10 (ten) days of receiving such Drawings. The review/approval of drawing should be authenticated by Construction Supervision Engineer.
- 5.3 Quality Assurance Manual and Plan forms the basis of quality of the work. It is therefore essential that the Quality Assurance Manual and Plan prepared by the Contractor be checked and approved. Thus, the Project Management Consultant shall check contents of Quality Assurance Plan and Manual of Contractor as per requirements of Quality Management System (as per ISO 9001), IRC: SP: 47-1998 and IRC: SP: 572000 for road bridges and roads respectively. The Project Management Consultant shall also offer their comments for modifying/ improving the document. After receiving the corrected document, the Project Management Consultant shall review and formally approve the QAM and Quality Plan and send one copy to the Employer. The Project Management Consultant shall complete the review of the methodology proposed to be adopted by the Contractor for executing the Works, and convey its comments to the Contractor within a period of 10 (ten) days from the date of receipt of the proposed methodology from the Contractor.
- 5.4 The Project Management Consultant in consultation with IE/NHAI shall grant written approval to the Contractor, where necessary, for interruption and diversion of the flow of traffic in the existing lane(s) of the Project Highway for purposes of maintenance during the Construction Period in accordance with the provisions of Clause 10.4 EPC Agreement.
- 5.5 The Project Management Consultant shall review the monthly progress report furnished by the Contractor and send its comments thereon to the contractor within 7 (seven) days of receipt of such report. The PMC shall send their comments to the Employer for their review.
- 5.6 On a daily basis, the concerned key personnel of Project Management Consultant shall inspect the Construction Works. Following activities need to be undertaken during the visits.
  - Review of construction including progress, quality and safety of construction
  - Inspection of defects and deficiencies in construction works
  - Witnessing quality inspection tests at labs established by Contractor on a sample basis

Review of quality of work shall be done in reference to Quality Assurance Plan (QAP)/Manual and ISO 9001:2008, IRC: SP: 47-1998 and IRC: SP: 57-2000 for road bridges and roads respectively. The Project Management Consultant also needs to capture following documents and send to Barwa Adda Expressway Limited (BAEL) field office via email on a daily basis

- Scanned copy of filled RFI (Request for Inspection) form including commentary on 'Satisfactory/Unsatisfactory' nature of work completed by Contractor
- Daily inspection report Proforma as provided in Annexure I
- Readings of quality inspection tests witnessed by the Consultant
- Minimum 6 high resolution photographs supporting the remarks made by the Project Management Consultant in RFI form

Team Leader will be responsible for sending daily emails to Barwa Adda Expressway Limited (BAEL) office

- 5.7 On a monthly basis, the Project Management Consultant shall prepare a **Monthly Inspection Report** in accordance with the format prescribed in **Annexure V** setting forth an overview of the status, progress, quality and safety of construction, including the work methodology adopted, the materials used and their sources, and conformity of Construction Works with the Scope of the Project and the Specifications and Standards. In a separate section of the Inspection Report, the Project Management Consultant shall describe in reasonable detail the lapses, defects or deficiencies observed by it in the construction of the Project Highway. The Project Management Consultant shall send a copy of its Inspection Report to the Employer /IE/NHAI and the Contractor latest by 7<sup>th</sup> of every month. Key sections of the Monthly Progress Report are as follows.

S No.	Section	Sub-Sections
1	<b>Executive Summary</b>	1.1 Construction progress in current month
		1.2 Summary of strip plan
		1.3 Detailed strip plan
		1.4 Current issues and recommended actions by CSE
2	<b>Project Overview</b>	2.1 Salient Features of the Project
		2.2 Project Milestones
		2.3 Location Map
		2.4 Key Plan
3	<b>Critical issues and Action log</b>	3.1 Pending issues and action log
		3.2 Obligations as per contract
4	<b>Physical Progress</b>	4.1 Detailed physical progress by component
5	<b>Land Acquisition and Clearances</b>	5.1 LA summary
		5.2 LA detail by CALA
		5.3 LA detail by village
		5.4 Manpower with each CALA
		5.5 Clearances summary
		5.6 Status of utility shifting
6	<b>Change of Scope</b>	6.1 Status of pending COS proposals



<b>S No.</b>	<b>Section</b>	<b>Sub-Sections</b>
7	<b>Mobilization of Resources</b>	7.1 Resource mobilization by contractor/ concessionaire
8	<b>Financial Progress Details</b>	8.1 Pen picture- Escrow
		8.2 Escrow details
9	<b>Summary of quality control tests</b>	9.1 Tests witnessed by IE/AE
		9.2 Tests conducted by IE/AE
10	<b>Monitoring of maintenance</b>	10.1 Critical issues and action log
	<b>obligations during construction phase</b>	10.2 Cumulative defects and deficiencies
		10.3 Status of damages
11	<b>Safety features</b>	11.1 Pen picture on safety features at construction site
		11.2 Accident report
12	<b>Annexures</b>	Annex 1: Detailed list of physical components as per Schedule G
		Annex 2 onwards: Additional details provided by CSE

- 5.8 If at any time during the Construction Period, the Project Management Consultant determines that the Contractor has not made adequate arrangements for the safety of workers and Users in the zone of construction or that any work is being carried out in a manner that threatens the safety of the workers and the Users, it shall make a recommendation to the Employer forthwith, identifying the whole or part of the Construction Works that should be suspended for ensuring safety in respect thereof.
- 5.9 The Project Management Consultant shall conduct the pre-construction review of manufacturer's reports and standard samples of manufactured Materials, and such other Materials as the Project Management Consultant may require.
- 5.10 For determining that the Works conform to Specifications and Standards, the Project Management Consultant shall require the Contractor to carry out, or cause to be carried out, tests at such time and frequency and in such manner as specified in the Agreement and in accordance with Good Industry Practice for quality assurance. For purposes of this, the tests specified in the IRC Special Publication-11 (Handbook of Quality Control for Construction of Roads and Runways) and the Specifications for Road and Bridge Works issued by MORT&H (the "Quality Control Manuals") or any modifications/substitution thereof shall be deemed to be tests conforming to Good Industry Practice for quality assurance.
- 5.11 The Project Management Consultant shall test check at least 60(sixty) percent of the quantity or number of tests prescribed for each category or type of test for quality control by the Contractor.

- 5.12 The timing of tests referred to in Paragraph 5.10, and the criteria for acceptance/rejection of their results shall be determined by the Project Management Consultant in accordance with the Quality Control Manuals. The tests shall be undertaken on a random sample basis and shall be in addition to, and independent of, the tests that may be carried out by the Contractor for its own quality assurance in accordance with Good Industry Practice.
- 5.13 In the event that results of any tests conducted under Clause 11.10 establish any Defects or deficiencies in the Works, the Project Management Consultant shall require the Contractor to carry out remedial measures.
- 5.14 The Project Management Consultant may instruct the Contractor to execute any work which is urgently required for the safety of the Project Highway, whether because of an accident, unforeseeable event or otherwise; provided that in case of any work required on account of a Force Majeure Event, the provisions of Clause 21.6 of EPC Agreement shall apply.
- 5.15 In the event that the Contractor fails to achieve any of the Project Milestones, the Project Management Consultant shall undertake a review of the progress of construction and identify potential delays, if any. If the Project Management Consultant shall determine that completion of the Project Highway is not feasible within the time specified in the Agreement, it shall require the Contractor to indicate within 15 (fifteen) days the steps proposed to be take to expedite progress, and the period within which the Project Completion Date shall be achieved. Upon receipt of a report from the Contractor, the Project Management Consultant shall review the same and send its comments to the Employer and the Contractor forthwith.
- 5.16 The Project Management Consultant shall obtain from the Contractor a copy of all the Contractor's quality control records and documents before the Completion Certificate is issued pursuant to Clause 12.2 of EPC Agreement.
- 5.17 Project Management Consultant may recommend to the Employer for suspension of the whole or part of the Works if the work threatens the safety of the Users and pedestrians. After the Contractor has carried out remedial measure, the Project Management Consultant shall inspect such remedial measures forthwith and make a report to the Employer recommending whether or not the suspension hereunder may be revoked.
- 5.18 In the event that the Contractor carries out any remedial measures to secure the safety of suspended works and users, and requires the Project Management Consultant to inspect such works, the Project Management Consultant shall inspect the suspended works within 3 (three) days of receiving such notice, and make a report to the Employer forthwith, recommending whether or not such suspension may be revoked by the Employer.
- 5.19 The Project Management Consultant shall carry out, or cause to be carried out, all the Tests specified in Schedule-K and issue a Completion Certificate or Provisional Certificate as the case may be. For carrying out is functions under this Paragraph

4.18 and all matters incidental thereto, the Project Management Consultant shall act under and in accordance with the provisions of Article 12 and Schedule-K. The Project Management Consultant shall use following equipment in carrying out the tests.

<b>S No</b>	<b>Key metrics of Asset</b>	<b>Equipment to be used</b>
1	Surface defects of pavement	Network Survey Vehicle (NSV)
2	Roughness of pavement	Laser Profilometer
3	Strength of pavement	Falling Weight Reflectometer (FWD)
4	Bridges	Mobile Bridge Inspection Unit (MBIU)
5	Road signs and road markings	Retro-reflectometer

## **6 Maintenance Period**

### **Deleted**

## **7 Determination of costs and time**

- 7.1 The Project Management Consultant shall determine the costs, and/or their reasonableness, that are required to be determined by it under the Agreement.
- 7.2 The Project Management Consultant shall determine the period of Time Extension that is required to be determined by it under the Agreement.
- 7.3 The Project Management Consultant shall consult each Party in every case of determination in accordance with the provisions of the EPC Agreement.

## **8 Payments**

- 8.1 The Project Management Consultant shall advise to the Employer on withhold of any payments for the affected works for which the Contractor fails to revise and resubmit the Drawings to the Project Management Consultant

### **8.2 Project Management Consultant shall**

- (a) within 10 (ten) days of receipt of the Stage Payment Statement from the Contractor pursuant to relevant Clause of the EPC Agreement, determine the amount due to the Contractor and recommend the release of 80 (ninety) percent of the amount so determined as part payment, pending issue of the Interim Payment Certificate; and
- (b) within 15 (fifteen) days of the receipt of the Stage Payment Statement referred to in the EPC Agreement, deliver to the Employer and the Contractor an Interim Payment Certificate certifying the amount due and payable to the Contractor, after adjustments.
- 8.3 The Project Management Consultant shall, within 15 (fifteen) days of receipt of the First stage Maintenance Payment Statement from the Contractor, verify the Contractor's statement and certify the amount to be paid to the Contractor in accordance with the provisions of the Agreement.

- 8.4 The Project Management Consultant shall certify final payment with 30 (thirty) days of the receipt of the final payment statement

## **9 Other duties and functions**

The Project Management Consultant shall perform all other duties and functions as specified in the Agreement.

## **10 Miscellaneous**

- 10.1 All key personnel and sub professional staff of the Project Management Consultant shall use the fingerprint based (biometric) attendance system for marking their daily attendance. Attendance shall be marked at least once a day and anytime during the day. 1 Biometric Attendance System shall be installed by the Project Management Consultant at its own cost at the site office in order to facilitate the attendance marking. More systems can be installed near the project highway upto a maximum of 1 system per 50 km in order to encourage frequent visits of project highway by key personnel and sub professional staff. A copy of monthly attendance records shall be attached with Monthly Status Report. Proper justification shall be provided for cases of absence of key personnel/ sub professional staff which do not have prior approval from Project Director of concerned stretch. In addition, Advance Face Recognition location based Mobile Application System (e-Attendance System) shall mandatorily be used for marking the attendance pursuant to NHAI Policy Circular no. 10.2.28/2021 dated 15.01.2021 (and any subsequent amendment thereof, if any).
- 10.2 A copy of all communications, comments, instructions, Drawings or Documents sent by the Project Management Consultant to the Contractor post approval of IE/NHAI pursuant to this TOR, and a copy of all the test results with comments of the Project Management Consultant thereon, shall be furnished by the Project Management Consultant to the Employer forthwith.
- 10.3 The Project Management Consultant shall retain at least one copy each of all Drawings and Documents received by it, including 'as - built' Drawings and keep them in its safe custody.
- 10.4 Within 90 (ninety) days of the Project Completion Date, the Project Management Consultant shall obtain a complete set of as built Drawings in 2 (two) hard copies and in micro film form or in such other medium as may be acceptable to the Employer, reflecting the Project Highway as actually designed, engineered and constructed, including an as built survey illustrating the layout of the Project Highway and setback lines, if any, of the buildings and structures forming part of project Facilities; and shall hand them over to the Employer/IE/NHAI against receipt thereof.
- 10.5 The Construction Supervision Engineer, if called upon by the Employer or the Contractor or both, shall mediate and assist the Parties in arriving at an amicable settlement of any Dispute between the Parties.
- 10.6 The Project Management Consultant shall inform the Employer and the Contractor of any event of Contractor's Default within one week of its occurrence.

## 11. PERFORMANCE CLAUSE

Construction Supervision Engineers shall be expected to fully comply with all the provisions of the 'Terms of Reference', and shall be fully responsible for supervising the Designs, Construction and maintenance and operation of the facility takes place in accordance with the provisions of the EPC Agreement and other schedules. Any failure of the Consultants Engineer in notifying to Employer and the Contractor on non-compliance of the provisions of the EPC Contract Agreement and other schedules by the EPC Contractor, non-adherence to the provision of ToR and non-adherence to the time schedule prescribed under ToR shall amount to non-performance.

The Project Management Consultant shall appoint its authorized representative, who shall issue on behalf of the Consultant, issue Completion Certificate along in consultation with the Team Leader and shall carry out any such task as may be decided by Employer. The Consultant shall take prior approval of Employer before issuing Completion Certificate. The proposal submitted shall also include the name of the authorized representative along with the authorization letter and power of attorney.

## 12. CONSULTANT'S PROPOSAL

12.1 List of key personnel to be fielded by the Consultants shall be as below:

### Normal Highway Project:

- i** Team Leader Cum Senior Highway Engineer
- ii** Resident cum Highway Engineer
- iii** Senior Quantity cum Material Expert
- iv** Bridge/Structural Engineer
- v** Senior Pavement Specialist
- vi** Road Safety Expert

12.2 Broad job-description and minimum qualification for key personnel mentioned above is enclosed as **Enclosure-B**. However, higher marks shall be accorded to the Candidate with higher relevant qualification and experience. All the CV's of the personals mentioned in Para5.3 (iii) of Data Sheet shall be evaluated at the time of evaluation of technical proposal. The **age of the Key Personnel should not be more than 65 years on the date of submission of proposal**. Consultants are advised in their own interest to frame the technical proposal in an objective manner as far as possible so that these could be properly assessed in respect of points to be given as part of evaluation criteria. The bio-data of the key personnel should be signed on every sheet by the personnel concerned and the last sheet of each bio-data should also be signed by the authorised signatory for the Consultant. The key personnel shall also certify at the end of their bio-data proforma that they have not left any of the Employer works without completing of their assignment and have not accepted any other offer at the time of signing of the bio-data and as such shall be available to work with the Construction Supervision Engineer, if the Project is awarded. In case the key personnel leaves the assignment without approval of Employer,

Employer would bear liberty to take any appropriate action against that key personnel including debarment. The CV submitted by selected firm/JV shall be hoisted on official website of Employer.

- 12.3 In addition to above, consultants are required to propose other key personnel, sub-professional staff and other field engineers as detailed in **Enclosure-A** and the minimum qualification requirements for the same is enclosed in **Enclosure-B**.

**13. PERIOD OF SERVICES**

- 13.1 The services of an Project Management Consultant will be in phases as per Contract Agreement.

- 13.1.1 The appointment of the Project Management Consultant shall initially be as per details given below.

<b>Period of service (in months)</b>	<b>Construction period (in months)</b>	<b>Maintenance/ DLP Period (in months)</b>
Construction Period	18 months	NA

The proposed manpower deployment for this period shall be matching the activities to be performed during the said period. The time frame for services during the deployment of key personnel during this period shall be as shown in **Enclosure A**. Extension of Time for providing services of the Project Management Consultant may be extended concurrently with the Extension of Time granted, if any, to the EPC Contractor for the project, subject to satisfactory performance of the Project Management Consultant and limited to original period of consultancy services.

**14. Project Coordinator**

The Firm shall appoint a personnel from its head office to act as Project Coordinator for the assignment. He will be authorised to communicate with the Employer in respect of all matters pertaining to the project. The cost of the Project Coordinator shall be incidental to the Consultancy Assignment.

**15.**

- i. Completion certificate of the project shall not be issued by Project Management Consultant with retrospective effect and without ascertaining that all the works have been completed as per Specifications and Standards, particularly ancillary items like shoulders, road signs, markings, road furniture items etc. Issuance of such completion certificate, besides being a fraudulent activity, leads to financial implication such as payment of Bonus even when the works are not fully completed. Ministry has earlier issued guidelines vide letter dated 22.03.2019 on issuance of completion certificate
- ii. MPR are required to be prepared properly by the Consultant to reflect the actual progress, hindrances, deployment of resources by the contractor, quality control, Nonconformity reports, safety, fulfilment of obligations of contractor and consultant including approval of various documents, design & drawings. The Consultant shall record all aspects as per services to be provided in terms of Reference (ToR), failing which the Consultancy firm shall be

warned for non-performance. In case Consultancy firm continues to default, even after multiple warning exceeding 5 times, the firm shall be put on holiday listing (temporary debarment) for a period upto 12 months from future assignments by MoRTH or its Executing Agencies.

**MAN - MONTHS INPUT FOR KEY PROFESSIONAL STAFF  
CONSTRUCTION SUPERVISION ENGINEER**

**Normal Highway Project  
(For projects with length Km 398.240 to Km 521.120 (122.88 Kms))**

S. No.	Key Personnel	Man-month in Construction period of 18 months	Man-month in Defect Liability Period of -- months
<b>A: Key Personnel</b>			
1	Team Leader Cum Senior Highway Engineer -1	18	0
2	Resident cum Bridge Engineer-1	18	0
3	Bridge/Structural Engineer -1	15	0
4	Highway Engineer-2	15	0
5	Senior Quality cum Material Expert-2	15	0
6	Road safety Expert -1	15	
7	Quantity Surveyor / Planning Engineer-2	18	
8	Survey Engineer-2	15	
	<b>Sub Total</b>		
	<b>Total for Construction</b>		
<b>B: Sub Professional Staff</b>			
	Contract specialist	0	
	Highway Design Engineer	0	
	Bridge/Structure Design Engineer	0	
	Survey Engineer (1 no.)	0	
	Assistant Highway Engineer (1 nos)	0	
	CAD Expert	0	
	Environmental Engineer	0	
	Assistant Bridge Engineer (1 no)	0	
	Assistant Quality cum Material Engineer (1 nos)	0	
	Quantity Surveyor	0	
	Horticulture cum Landscaping Expert	0	
	<b>Sub Total</b>		
	<b>Total for Construction and Maintenance</b>		
	<b>Grand Total</b>		

**Note:**

- The Man-months shall be adjusted accordingly if the Project in case of early completion of the project.



2. The other inputs like support staff shall be provided by the Consultant of an acceptable type commensurate with the roles and responsibilities of each position
3. In case of project having different construction period, Man Month Input shall be adjusted proportionately
4. The Financial Expert or Legal expert or Contract Specialist may be required for the project for specific needs. Their deployment shall be arranged by the Consultant on specific requisition from the Employer and the payment shall be made as per the actual deployment. The Financial Expert or Legal expert or Contract Specialist shall be paid at the rates quoted for Senior Pavement Specialist.

## QUALIFICATION OF KEY PERSONNEL

### TEAM LEADER CUM SENIOR HIGHWAY ENGINEER

This is the senior most position and the expert engaged as the team leader shall be responsible for reviewing the entire Project preparation and implementation activities of the Contractor. He shall check all the Designs being prepared by the Contractor, ensure execution of works on site as per specification and standards, and continuously interact with the Barwa Adda Expressway Limited (BAEL) and the Contractor. He shall undertake Project site visits and shall guide, supervise, coordinate and monitor the work of other experts in his team as well as those of the Contractor. The candidate is required to be a Senior Highway Engineer, who should have a proven record of supervising, organising and managing of construction of highway projects and also of Project preparation of large magnitudes projects, as defined below, financed by international lending agencies and others. Knowledge of Project management shall be an added advantage.

He should have the following qualification / experience.

#### 1. Essential Qualifications.

- a) Graduate in Civil Engineering from recognized university.
- b) Total Professional Experience of at least 12 years in handling Highway Projects.
- c) At least 5 years' experience as Team Leader/Project Manager or similar capacity in Highway Development Project.
- d) He should have handled as Team Leader/Project Manager or similar capacity of at least two projects in Construction Supervision / IC (of length 40% of project length or more of similar configuration (2/4/6 laning\*\*))
- e) He should have handled as Team Leader or similar capacity of at least two Projects of project Preparation of major highway Project (of length 40% of project length or more of similar configuration (2/4/6 laning\*\*)).
- f) Experience as Team Leader/Project Manager or similar capacity in Operation and Maintenance of Major Highway Projects (of length 40% of project length or more of similar configuration (2/4/6 laning\*\*)).

#### 2. Preferential Qualifications.

- a) Post Graduate Degree in Construction Management/Transportation/Highway Engineering//Structural Engineering/ any specialised stream of Civil Engineering.
- b) Highway Development Projects (of length 40% of project length or more of similar configuration (2/4/6 laning\*\*)) taken up under EPC.
- c) Degree/Diploma/Certificate in Project Management

**Note:** (1) Similar Capacity includes the following positions

- i. On behalf of Consultant: Team Leader / Resident Engineer (Construction

Supervision/IE/AE).

- ii. On behalf of Contractor : Project Manager (Construction/ Construction Supervision) iii. In Government Organizations : Superintending Engineer (or equivalent) and above

(2) Only those projects will be considered for evaluation at Sl. No. 1(d), 1(e) & 1(f) above, where the input of the personnel is 12 months, 9 months and 12 months respectively.

### **RESIDENT CUM HIGHWAY ENGINEER**

The Resident cum Highway Engineer shall be responsible for supervising the works of highway to be constructed by the Contractor for this project. He shall also inspect the pavement rehabilitation and repair works to be undertaken by the Contractor.

He should have the following qualification / experience.

#### **1. Essential Qualifications.**

- a) Graduate in Civil Engineering from a recognized University.
- b) Professional Experience of at least 12 years in Highway Projects.
- c) At least 5 years' experience in similar capacity in Highway Development Project.
- d) Should have handled at least 2 major projects (of length 40% of project length or more of similar configuration (2/4/6 laning\*\*) and above).

#### **2. Preferential Qualifications.**

- a) Post Graduate Degree in Transportation/Highway Engineering/Structural Engineering/Geotechnical Engineering/any specialised stream of Civil Engineering.
- b) Experience of Highway Project (of length 40% of project length or more of similar configuration (2/4/6 laning\*\*) and above) of Construction / Construction Supervision / IC of Highway projects

### **BRIDGE & STRUCTURAL ENGINEER**

The Bridge& Structural Engineer shall be responsible for checking the designs of bridges, ROBs, interchanges and any other structure to be constructed in the Project highway and supervising the works of bridges, interchanges and any other structure to be constructed by the Contractor for this project. He shall also inspect the bridge rehabilitation and repair works to be undertaken by the Contractor. He should have thorough understanding and experience with international 'best practices' of modern bridge construction technology.

He should have the following qualification / experience.

#### **1. Essential Qualifications.**

- a) Graduate in Civil Engineering from a recognized University.
- b) Professional Experience of at least 10 years in handling Highway/Bridge projects.

- c) At least 5 years' experience in Construction / Construction Supervision of bridge / interchange / any other structures.
- d) Experience in similar capacity in supervision of at least 2 Major Highway Bridges.
- e) Experience in supervision of Rehabilitation and repair of 2 nos Major Bridges.

**2. Preferential Qualifications.**

- a) Post Graduate Degree in Structural Engineering.
- b) He should have thorough understanding and experience of modern bridge construction technology. viz., Precast Segmental, Balanced Cantilever Construction, Extradosed Bridge, Full Span Launching, Incremental Launching.

**SENIOR PAVEMENT SPECIALIST**

The expert shall be continuously interacting with the Contractor, for the review of highway designs and drawings using sophisticated computer software and also construction and O&M works and to ensure life cycle cost effectiveness and viable design of pavement including appropriate rehabilitation / strengthening of the existing two lane pavement which is significantly distressed. He shall also be responsible for ensuring complete adherence to maintenance standards during Construction and Operation period. Thus, the position requires a pavement specialist with thorough knowledge and understanding of international 'best practices' in the field of Design, Construction and maintenance of flexible/rigid type of pavements including latest Codal stipulations and specifications.

He should have the following qualification / experience.

**1. Essential Qualifications.**

- a) Graduate in Civil Engineering from a recognized University.
- b) Professional Experience of at least 10 years in Pavement Design / Pavement Construction / Pavement Maintenance of Highways / Roads / Airfield Runways
- c) Experience of at least 5 years in similar capacity in Construction / Construction Supervision of 2/4/6 laning\*\* of major highway projects.
- d) Experience as Pavement / Geotechnical Engineer in Construction/Construction Supervision of at least 2 major highway projects (of length 40% of project length or more of similar configuration (2/4/6 laning\*\*) and above).

**2. Preferential Qualifications.**

- a) Post Graduate Degree in Highway Engineering / Pavement Engineering /Transportation Engineering
- b) Experience as a Pavement Specialist/Pavement Engineer in Highway project(of length 40% of project length or more of similar configuration (2/4/6 laning\*\*) and above).

### **SENIOR QUALITY/MATERIAL EXPERT**

The Quality/Material Expert shall review the test results of bore holes, quarry and borrow area material to find out their strength characteristics and suitability for using them in

construction. He shall inspect the Contractor's field laboratories to ensure that they are adequately equipped and capable of performing all the specified testing requirements of the contract. He shall look into the quality assurance aspect of the construction works and supervise the setting-up of the various Contractor's rock crushers and bituminous mixing plants to ensure that the specified requirements for such equipment are fully met. Experience in latest Quality Management techniques in highway projects shall have added advantage.

He should have the following qualification / experience.

#### **1. Essential Qualifications.**

- a) Graduate in Civil Engineering from a recognized University.
- b) Professional Experience of at least 10 years in handling Highway projects.
- c) Experience of at least 5 years as Senior Quality/ Material Expert or in similar capacity in Construction / Construction Supervision /major highway projects
- d) Experience as Senior Quality/ Material Expert or in similar capacity in handling of at least 2 similar highway projects. (of length 40% of project length or more of similar configuration (2/4/6 laning\*\*) and above)

#### **2. Preferential Qualifications.**

- a) Post Graduate Degree in Geotechnical Engineering / Foundation Engineering / Soil Mechanics.

## **ROAD SAFETY EXPERT**

Shall be responsible for the overall Road Safety Aspect of the Project. He shall ensure that safety provisions as per relevant codes are strictly followed at site during Construction of Road and also during the Maintenance Period

### **1. Essential Qualifications.**

- a) Graduate in Civil Engineering from a recognized University.
- b) Professional Experience of at least 10 years in handling Highway projects.
- c) Minimum 5 years experience in Road Safety works of Major Highway Projects (4 / 6 laning projects)
- d) Experience in similar capacity in Road Safety Audit of at least 2 nos. 2/4/6 lane\*\* highway / expressway project including 1 nos. at design stage
- e) Experience in similar capacity in the field of Road Safety Management Plan.
- f) It is mandatory for the Road Safety Expert to have completed at least 15 days' certification course on Road safety Audit from IAHQ/ IITs/ NITs/ CRRI. The CV of the proposed key personnel not having completed 15 days' certification course shall not be evaluated. For avoidance of doubt, it is clarified herein that the certification training course may be either from a single institution or from multiple institutions.

### **2. Preferential Qualifications**

- a) Post Graduate Degree in Traffic Transportation/Safety Engineering.
- b) Experience in similar capacity in identification and improvement of black spots on Major Highway Project.
- c) Experience in similar capacity in Preparation of Road Safety Management Plan for inter urban Highways.

## **TEAM LEADER CUM SENIOR BRIDGE ENGINEER**

This is the senior most position and the expert engaged as the team leader shall be responsible for reviewing the entire Project preparation and implementation activities of the Contractor. He shall check all the Designs being prepared by the Contractor, ensure execution of works on site as per specification and standards, and continuously interact with the Barwa Adda Expressway Limited (BAEL) and the Contractor. He shall undertake Project site visits and shall guide, supervise, coordinate and monitor the work of other experts in his team as well as those of the Contractor. The candidate is required to be a Senior Bridge Engineer, who should have a proven record of supervising, organising and managing of construction of Bridge projects and also of Project preparation of large magnitudes projects, as defined below, financed by international lending agencies and others. Knowledge of Project management shall be an added advantage.

He should have the following qualification / experience.

### **1. Essential Qualifications.**

- a) Graduate in Civil Engineering from recognized university.
- b) Total Professional Experience of at least 12 years in handling Bridge Projects.
- c) At least 5 years experience as Team Leader/Project Manager or similar capacity in Highway Development Project.
- d) He should have handled as Team Leader/Project Manager or similar capacity of at least two projects in Construction Supervision / IC (of length 40% of project length or more of similar configuration (2/4/6 laning\*\*))
- e) He should have handled as Team Leader or similar capacity of at least Two projects in Construction Supervision / AE/ IE/ Project preparation involving at least one Major Bridge (minimum 300 m length without approaches) in the Project (of length 40% of project length or more of similar configuration (2/4/6 laning\*\*))
- f) Experience as Team Leader/Project Manager or similar capacity in Operation and Maintenance of Major Bridge (minimum 300 m length without approaches) in the Project (of length 40% of project length or more of similar configuration (2/4/6 laning\*\*)).

### **2. Preferential Qualifications.**

- a) Post Graduate Degree in Structural Engineering or equivalent.
- b) Highway Development Projects (of length 40% of project length or more of similar configuration (2/4/6 laning\*\*)).

c) Degree/Diploma/Certificate in Project Management

**Note:** (1) Similar Capacity includes the following positions

- i. On behalf of Consultant: Team Leader / Resident Engineer (Construction Supervision/IE/AE).
- ii. On behalf of Contractor : Project Manager (Construction/ Construction Supervision)
- iii. In Government Organizations : Superintending Engineer (or equivalent) and above

(2) Only those projects will be considered for evaluation at Sl. No. 1(d), 1(e) & 1(f) above, where the input of the personnel is 12 months, 9 months and 12 months respectively.

### **TEAM LEADER CUM SENIOR TUNNEL ENGINEER**

Duties: The Team Leader will reside at project site throughout the period of construction supervision services. He will be overall in-charge of the project supervision of the construction package. He shall act as representative of the consulting firm appointed by the Employer. His duties will involve overall superintendence over the Resident Engineers and other experts of the construction package. He will guide, monitor, supervise and control all the activities related to supervision for the construction package. He will interact with the Project Director/ General Manager and the other officials of the Employer. He should have the following qualification / experience.

#### **(1) Essential Qualifications.**

- a) Graduate in Civil/Mining Engineering or equivalent from a recognized university.
- b) Total professional experience of at least 20 years
- c) Professional Experience of at least 15 years in handling major tunnelling projects
- d) He should be involved in at least 10 years in construction/construction supervision of major Road/ Rail/ Metro tunnel projects
- e) At least 5 years' experience as Team Leader/Resident Engineer/Project Manager or similar capacity in supervision of transportation tunnel projects of length equal to or more than 4 km
- f) He should have handled as Team Leader or similar capacity of at least two projects in Construction Supervision of transportation tunnels equal to more than 4 Km length
- g) Not more than 65 years of age.

#### **(2) Preferential Qualifications.**

- a) Post Graduate or chartered engineer in Mining Engineering/ Geotechnical Engineering/ Structural Engineering/ Rock Mechanics or equivalent.
- b) Project preparation/ design experience of transportation Tunnel projects

**Note:** (1) Similar Capacity includes the following positions

- i) On behalf of Consultant: Team Leader / Resident Engineer/Professional



Engineer/Chartered Engineer (Construction Supervision/IE/AE).

ii) On behalf of Contractor : Project Manager/ Professional Engineer/Chartered Engineer (Construction/ Construction Supervision)

iii) In Government Organizations : Superintending Engineer (or equivalent) and above

(2) Only those projects will be considered for evaluation at Sr. no 1(d), 1(e) and 1(f) where the input of the personnel is at least of one year.

(3) Unless otherwise mentioned specifically, tunnel projects of length  $\geq 1.5\text{km}$  shall be considered as major tunnel projects.

### **RESIDENT ENGINEER CUM TUNNEL EXCAVATION EXPERT**

Duties: He shall oversee construction supervision of the project stretch and shall coordinate with all other experts of the project and shall report to the Team Leader. He shall be directly responsible for regulating the construction process. He shall be assisted by Tunnel Engineers, Tunnel Lining Experts and Tunnel ventilation Expert and other support engineers/personnel. He shall deal directly with the tunnel engineers/experts and other support staff attached with the Team Leader to ensure that the construction process is well controlled as per established specification controls to avoid later quality control stage problems. Expert shall be responsible for checking and verifying the excavation plan and methodology submitted by the Contractor. He shall monitor the tunnel excavation activities including blasting. He shall also monitor the tunnel lining activities including installation of water proofing layers. He will be required to be fielded throughout the Currency of the project. The candidate is expected to be thoroughly familiar with various standard/specifications, contract procedures, Primavera or other project management software, design and quality control etc. In addition he will be responsible for tunnel works during Operation & Maintenance period of the project.

He should have the following qualification / experience.

#### **(1) Essential Qualifications.**

- a) Graduate in Civil/Mining Engineering from a recognized University.
- b) Total Professional Experience of at least 15 years
- c) He should have at least 10 years' experience in similar capacity for major tunnel projects
- d) At least 7 years' experience in construction supervision of major transportation tunnel construction projects
- e) Should have handled construction/construction supervision of at least 2 transportation Tunnel projects of length equal or more than 4 km
- f) Experience in tunnel design/ DPR preparation/ feasibility study/ design review of transportation Tunnel projects of length equal or more than 4 km
- g) Not more than 65 years of age.

#### **(2) Preferential Qualifications.**

- a) Post Graduate or chartered engineer in civil/mining

#### **Note:**

(1) Unless otherwise mentioned specifically, tunnel projects of length  $\geq 1.5$ km shall be considered as major tunnel projects.

## **TUNNEL DESIGN ENGINEER**

Duties: The Tunnel Design Engineer shall be responsible for checking the designs of tunnel/design review and other incidental works to be constructed in the Project using sophisticated computer software. He shall be responsible for Detailed Design Calculation and drawing for tunnels. He shall be responsible for comprehensive assessment of structural condition of all the tunnel assets. His expertise shall include computer aided design methods for Tunnel Engineering with particular reference to Tunnel design.

He should have the following qualification / experience.

### **(1) Essential Qualifications.**

- a) Graduate in Civil Engineering from a recognized University.
- b) Professional Experience of at least 20 years
- c) Experience of at least 12 years in major tunnel projects
- d) Experience in tunnel design (Road/ Rail/ Metro) of at least 12 years
- e) Experience in similar capacity in construction/construction supervision of 2 transportation tunnel projects of length at least equal to 4 Km each
- f) Experience in similar capacity in design of at least 3 transportation tunnel projects of length at least equal to 4 Km each
- g) Not more than 65 years of age.

### **2) Preferential Qualifications.**

- a) Post Graduate in Engineering in structural engineering
- b) Innovative transport tunnel design (road/ Rail/ Metro) such as immersed tunnel and sub-sea bored tunnel

### **Note:**

(1) Unless otherwise mentioned specifically, tunnel projects of length  $\geq 1.5$ km shall be considered as major tunnel projects.

## **SENIOR CONTRACT SPECIALIST**

Duties: He will be deployed in working season in stages for cumulative duration of period mentioned in Enclosure-A for obtaining his expert opinion on emerging contractual issues. His key responsibilities will be to guide and assist Team Leader/Employer in all aspects of contract management in proper implementation of contract provisions including controlling the project cost of the construction package. He will also be required to offer his advice on contractual complications arising during the implementation as per the request of the employer. He will be required to prepare manuals/schedules for the consultants team/employer based on the provisions of the contract document. He will be responsible for giving appropriate suggestions in handling claims of the contractors and any dispute arising thereof.

### **(1) Essential Qualifications.**

- a) Graduate in Civil Engineering from a recognized University.
- b) Professional Experience of 15 years in Contract Management.
- c) Experience of at least 4 years as Contract Specialist on any National/State Highway project/Bridge Project.
- d) Contract Management of a large Highway/Bridge contract say over Rs.150 crore including experience of handling Variation orders, claims of the contractor and there appropriate disposal for at least 2 projects.
- e) Handled at least one Arbitration cases in respect of any Highway/Bridge projects. f) Not more than 65 years of age.

### **(2) Preferential Qualifications.**

- a) Degree in Law/PG in management/certificate course in management/ certificate course in construction management/certificate course in contract management.

### **RESIDENT CUM PAVEMENT SPECIALIST**

The expert shall be continuously interacting with the Contractor, for the review of highway designs and drawings using sophisticated computer software and also construction and O&M works and to ensure life cycle cost effectiveness and viable design of pavement including appropriate rehabilitation / strengthening of the existing pavement. He shall also be responsible for ensuring complete adherence to maintenance standards during Construction and Operation period. Thus, the position requires a pavement specialist with thorough knowledge and understanding of international 'best practices' in the field of Design, Construction and maintenance of flexible/rigid type of pavements including latest Codal stipulations and specifications.

He should have the following qualification / experience.

#### **3. Essential Qualifications.**

- a) Graduate in Civil Engineering from a recognized University.
- b) Professional Experience of at least 12 years
- c) Experience of at least 5 years in similar capacity in Construction / Construction Supervision of 2/4/6 laning\*\* of major highway projects.
- d) Experience in similar capacity in handling at least 2 major highway projects (of length 40% of project length or more of similar configuration (2/4/6 laning\*\*) and above).

#### **4. Preferential Qualifications.**

- a) Post Graduate Degree in Highway Engineering/ Geotechnical Engineering/ Transportation Engineering/ Structural Engineering
- b) Experience in similar capacity in Highway project construction/ construction supervision on EPC mode (of length 40% of project length or more of similar configuration (2/4/6 laning\*\*) and above).

### **SUB PROFESSIONAL**

#### **Highway Design Engineer**

The Highway Design Engineer shall be responsible for the review of highway designs and drawings using sophisticated computer software. His experience shall include computer aided design methods for highway engineering with particular reference to CAD application to the geometric design for highway projects.

He should have following qualification/ experience:

#### **(1) Essential Qualifications**

- (i) Graduate in Civil Engineering from recognized University.
- (ii) Professional experience of 8 years in highway works.
- (iii) Experience of at least 4 years (out of total 8 years) in highway designing works.

- (iv) He should have handled as Highway Design Engineer at least 2 projects of similar configuration.
- (v) Exposure of Computer Software Programme for Design of Highways.

**(2) Preferential Qualification:**

- (a) Post graduate in Highway/ Pavement/ Transportation Engineering.
- (b) Experience in Highway Projects in innovative/ non – traditional technology and design.

**Bridge/ Structure Design Engineer**

The Bridge Design Engineer shall be responsible for checking the designs of Bridges, ROBs, interchanges and any other structure to be constructed in the Project Highways. He shall also review the rehabilitation measures to be proposed by the Contractor for existing structures based on site condition and structural requirement. His expertise shall include computer aided design methods for Structural Engineering with particular reference to structural design.

He should have following qualification/ experience:

**(1) Essential Qualifications**

- (i) Graduate in Civil Engineering from recognized University.
- (ii) Professional experience of 8 years in Bridge Design.
- (iii) 5 years out of total 8 years' experience in similar capacity for design of major highway bridges/ structures.
- (iv) Experience of designing of at least 2 major highway Bridges of similar configuration.

**(2) Preferential Qualification:**

- (a) Post graduate in structural Engineering.
- (b) Design experience of major highway bridge of length 200 m or more (excluding approaches)
- (c) Experience in similar capacity in innovative and specialized major bridge design (pre – cast segmental, cantilever construction, cable stayed bridge, suspension bridges etc.)

**SURVEY ENGINEER**

The candidate should be Graduate in Civil Engineering Firm may field Survey Engineer with diploma in Civil Engineering/Survey having at least 5 years' experience in the field of surveying out of which at least 3 years should be in highway projects and they should have also dealt with at least 1 project of similar nature. This position requires thorough understanding of modern computer based method of surveying with total station digital level etc.

**ASSISTANT HIGHWAY ENGINEER**

The Candidate should be Graduate in Civil Engineering.

**CAD EXPERT**

He should be Graduate in Civil Engineering/Computer Science having experience in computer related design method for highway engineering.

**ENVIRONMENTAL ENGINEER**

The Candidate should be Graduate in Civil Engineering/Environmental Engineering or other relevant qualification. He should have at least 6 years' experience out of which 2 years in highway projects. He should have good knowledge of MOEF guidelines/requirements for mitigation measures.

**ASSISTANT BRIDGE ENGINEER**

The Candidate should be Graduate in Civil Engineering with 3 years' experience. He should have handled at least 1 major bridge project.

**ASSISTANT QUALITY CUM MATERIAL ENGINEER**

The Candidate should be Graduate in Civil Engineering or diploma in Civil Engineering with 3 years' experience.

**ELECTRICAL ENGINEER**

The Candidate should be Graduate in Electrical Engineering from recognised institute. He should have at least 6 years' experience

**HTMS/TOLLING SYSTEM EXPERT**

The candidate should be a senior Systems Engineer having experience of at least 15 Years. He should be an expert in preparation of standards for projects of toll collection and HTMS. He should have bachelor's degree in Civil Engineering/Electronics/Computer Science/other relevant areas. He should have experience of international latest practices in the field of HTMS and tolling. He should have work experience on at least 2 similar projects in similar capacity.

**QUANTITY SURVEYOR**

He should be Graduate or equivalent in Civil Engineering having Min. 5 years of professional experience in preparation of highway project estimates. He should have Min. 3 years' experience in Preparation of Bill of Quantities/estimates for major highway projects costing Rs.100 Crore or above.

**HORTICULTURE CUM LANDSCAPING SPECIALIST**

He should be a Graduate in Agriculture with specialization in Horticulture/Arboriculture having minimum 5 year of field experience in Horticulture/Arboriculture and landscaping. He should have minimum 5 years field experience.

**Note:** Upto 2 sub-professional can be a fresh graduate (zero/ less than minimum required work experience) with first class in graduation stream. Eligibility requirement in terms of minimum years of experience shall not be applicable for this sub professional. However, this is not applicable to Highway Design Engineer and Bridge/ Structure Design Engineer, who have to fulfill the qualification/ experience requirements as mentioned in the RFP documents.

**Annexure I- Daily Inspection Report in construction period**

<b>Component</b>	<b>Item Description</b>	<b>Description of inspection work carried out</b>	<b>Results of lab tests conducted (Test conducted, Pass/Fail)</b>	<b>Name of key personnel inspecting the work</b>
1. Road works including culverts, and minor bridges	Embankment/ Sub Grade/ GSB/ WMM/ DBM/ BC			
2. Major Bridge works, Flyovers, ROB, RUB, VUP, PUP	Foundation/ Sub structure/ Super structure			
3. Approach to ROB/RUB/ Major Bridges/ Viaduct / RE wall	Foundation/ Sub structure/ Super structure			
4. Other Works				



**Annexure II- Daily Inspection Report in O&M period  
Deleted**

**Annexure III- Weekly Inspection Report in O&M period  
Deleted**

**Annexure IV- Month of survey for equipment based road condition assessment**

**Deleted**

**Annexure V- Monthly Progress Report in Construction Phase**

[NAME & LOGO OF IMPLEMENTING AGENCY]

*[PROJECT NAME]*

**Project Management Consultant**

*[NAME OF CONSULTING FIRM]*

**MONTHLY PROGRESS REPORT NO. [XX]**

**FOR THE MONTH OF: [MONTH], [YEAR]**

## **Table of Content**

<b>Contents</b>	<b>Page Nos.</b>
1 Executive Summary	106
1.1 Construction progress in current month	106
1.2 Current issues and recommended actions by IE / AE	106
1.3 Strip Plan (Summary)	107
1.4 Strip Plan (Details)	108
2 Project Overview	109
2.1 Salient Features of Project	109
2.2 Project Milestones	110
2.3 Location Map	111
2.4 Key Plan	112
3 Critical Issues & Action Log	113
3.1 Pending Issues & Action Log	113
3.2 Obligations as per Contract	114
4 Physical Progress	115
4.1 Detailed Scope of Work & Physical Progress by Component	116
5 Land Acquisition and Clearance	117
5.1 LA Summary	117
5.2 LA Detail by CALA	117
5.3 LA Detail by Village for each CALA	118
5.4 Manpower details of CALA	118
5.5 Clearances Summary	118
5.6 Status of utilities shifting	120
6 Change of Scope	120
7 Mobilization of Resources	120
8 Financial Progress Details (for PPP projects)	121
8.1 Pen Picture - Escrow	121

8.2 Escrow details	121
9 Summary of quality control tests	122
9.1 Tests witnessed by IE/ AE	122
9.2 Tests conducted by IE / AE	124
10 Monitoring of maintenance obligations during construction phase	125
10.1 Critical issues and action log	125
10.2 Summary of repair work	125
10.3 Status of damages	127
11 Safety features	127
11.1 Pen picture of safety features	127
11.2 Accident Report	128
12 Annexures	130

## 1 Executive Summary

### 1.1 Construction progress in current month

Key reporting metrics	Value/ %/ Amount
Scheduled Physical Progress (%)	
Cumulative Physical Progress upto current month (%)	
Physical Progress during current month (%)	
Financial progress (%)	
Cumulative Expenditure till date (Rs Cr)	
Tests passed as % of total tests witnessed by IE	
Tests passed as % of total tests conducted by IE	
Number of pending COS proposals	
Amount for pending COS (Rs Cr)	

### 1.2 Current issues and recommended actions by IE / CSE

1. **Slow Progress of Structures:** The progress of structures (especially, major bridges, flyovers and ROB's) is very slow. Overall progress is only XX%. Out of the total YY underpasses not even single underpass structure and its approaches is completed so far. No bridge is open to traffic sofar.
  - a. ***Recommendation:*** Contractor should improve the progress of structures. Request for revised workplan from Contractor including specific activities on structures.
  
2. **Status of Change of Scope Proposals:** Contractor has submitted Xx No. Change of Scope proposals. Yy No. of them are still pending for decision. Contractor has not submitted necessary clarifications /details for the following Changes of Scope in spite of several reminders.
  - a. ***Recommendation:*** Contractor to submit all pending clarifications to the Employer. Employer and Contractor to expedite pending COS proposals.

### 1.3 Strip Plan (Summary)

1. Work front Unavailable & Unavailability by layer (MCW)      2. Length completed by layer (MCW)      3. Length completed reason for by layer (Service Road)

	Length (km)	% Total Pending Length		Length (km)	% Total Length		Length (km)	% Total Length
<b>Total Length</b>	80		<b>Total Length</b>	80		<b>Total Length</b>	35	
<b>Total Workfront Unavailable</b>	7	12%	<b>Total Length Completed (Till DBM)</b>	27.5	33%	<b>Total Length Completed (Till DBM)</b>	0	0%
<b>Pending Land</b>	0	0%	<b>BC</b>	27	32%	<b>BC</b>	0	0%
<b>Acq. Pending</b>	7	12%	<b>DBM</b>	27.5	33%	<b>DBM</b>	0	0%
<b>Clearances</b>	0	0%	<b>WMM</b>	29.5	35%	<b>WMM</b>	0	0%
<b>Encumbrances</b>			<b>GSB</b>	32.5	39%	<b>GSB</b>	0	0%
			<b>Sub-Grade</b>	47.9	57%	<b>Sub-Grade</b>	0	0%
			<b>C&amp;G</b>			<b>C&amp;G</b>		





## Detailed report

### 2 Project Overview

#### 2.1 Salient Features of Project

<b>Project Name</b>	
<b>NH No. (New/ Old)</b>	
<b>Scheme/ Phase</b>	
<b>Mode of the Execution</b> (BOT Toll/ BOT Annuity/ EPC/ HAM/ Item Rate/ Others)	
<b>No. of Lanes/ Configuration</b>	
<b>Length of the Project (in Km)</b>	
<b>Total Project Cost (in Cr)</b>	
<b>No. of Bypasses</b> (Name of Town, Length)	
<b>No. of Major Bridges</b> (Number and Location)	
<b>No. of Toll Plazas</b> (Number and Location)	
<b>No. of Fly Overs</b> (Number and Location)	
<b>DPR Construction Supervision EngineerName</b>	
<b>Lead &amp; Consortium Members of Banks</b>	
<b>Contractor Name</b> (SPV & Parent Company)	
<b>Date of Award</b> (LOA Date)	
<b>Appointed Date</b>	
<b>Concession Period</b>	
<b>Construction Period</b> (in Days)	
<b>O&amp;M Period</b> (in Days)	
<b>Scheduled Date of Completion</b>	
<b>Project Management Consultant</b>	
<b>IE / CSE Agreement Date</b>	
<b>IE / CSE Mobilization Date</b>	

ALL FIGURES & GRAPHS IN TEMPLATES ARE ILLUSTRATIVE. PLEASE ADD ACTUAL DETAILS

## 2.2 Project Milestones

Project Milestone	Description (Days from Appointed Date)	Planned		Actual		Delay (No. of months)	Current Status
		Physical Progress (%)	Scheduled Date	Physical Progress (%)	Revised Date		
<b>Milestone I</b>	<i>[Description]</i>	25	<i>[DD/MM/YYYY]</i>	25	<i>[DD/MM/YYYY]</i>	5	Achieved
<b>Milestone II</b>	<i>[Description]</i>	65	<i>[DD/MM/YYYY]</i>		<i>[DD/MM/YYYY]</i>	22	Started, not achieved
<b>Scheduled Completion</b>	<i>[Description]</i>	100	<i>[DD/MM/YYYY]</i>		<i>[DD/MM/YYYY]</i>	21	Not started

ALL FIGURES & GRAPHS IN TEMPLATES ARE ILLUSTRATIVE. PLEASE ADD ACTUAL DETAILS

### 2.3 Location Map

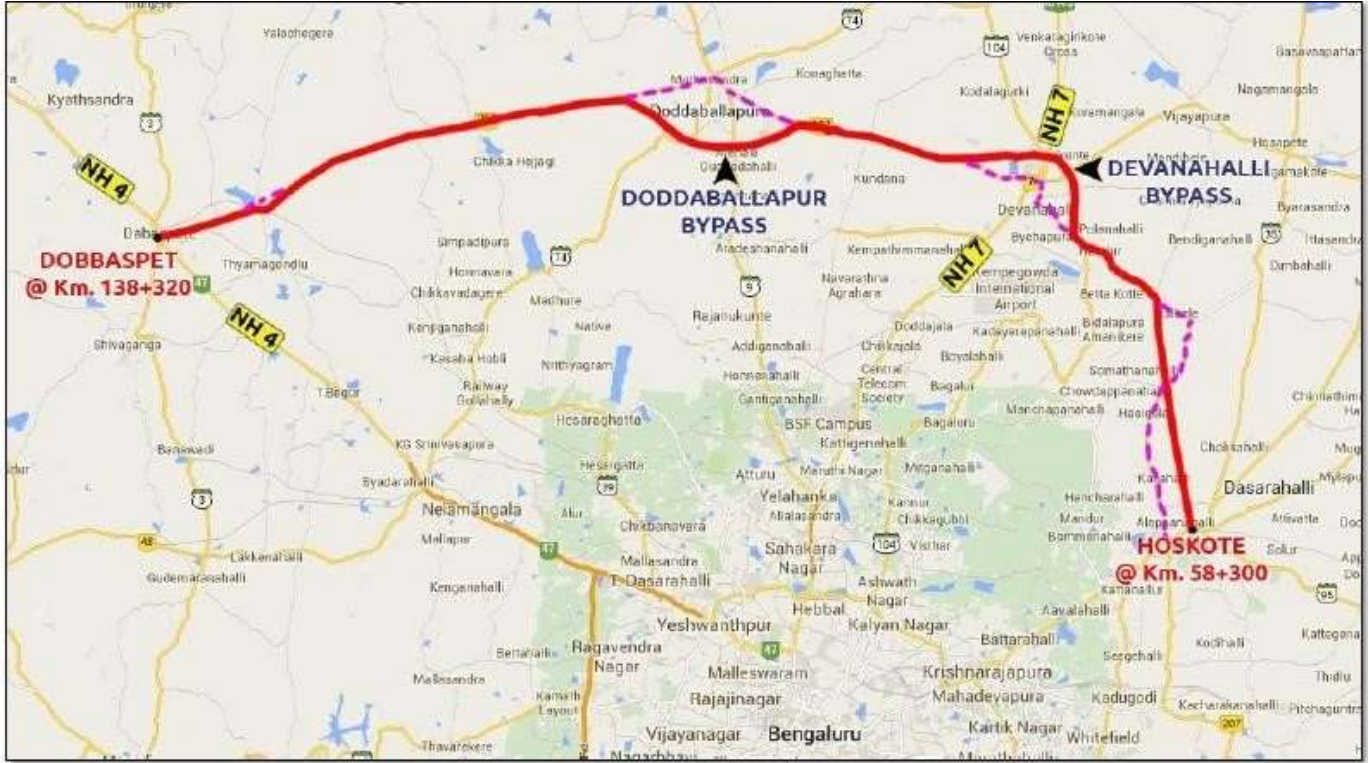

ALL FIGURES & GRAPHS IN TEMPLATES ARE ILLUSTRATIVE. PLEASE ADD ACTUAL DETAILS

### 2.4 Key Plan

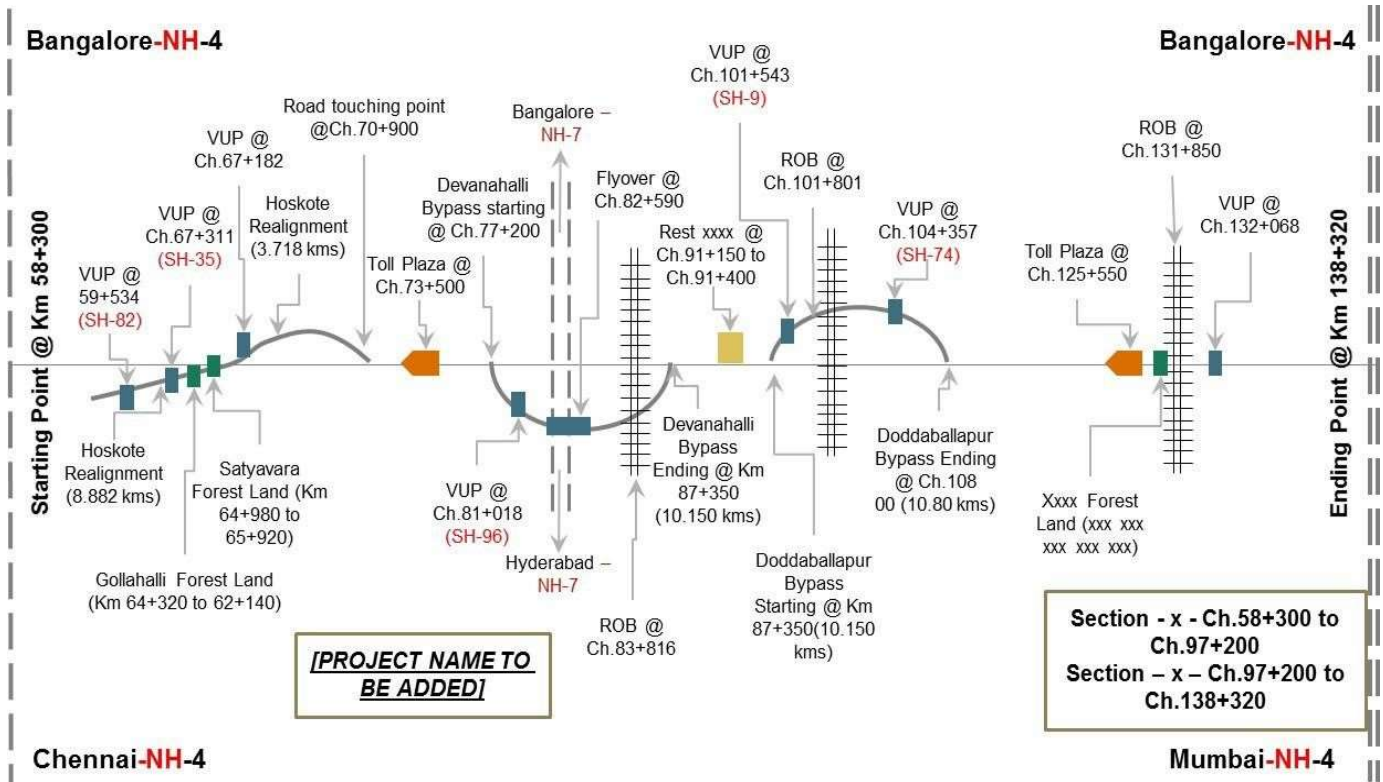

[Above image is illustrative only. Please include chainage and name below the axis and list of features above the axis]

ALL FIGURES & GRAPHS IN TEMPLATES ARE  
ILLUSTRATIVE. PLEASE ADD ACTUAL DETAILS

### 3 Critical Issues & Action Log

#### 3.1 Pending Issues & Action Log

S. No	Issue Description	Type	Ongoing/ New Issue / Resolved	Concerned Authority	Chainage(s) affected due to the issue	Length affected (km)	Action(s) taken till now	Action(s) suggested by the CSE	Expected date/ Actual Date for resolving issue
1	<b>Diversion of Xx ha of forest Land</b>	Clearance	<b>Ongoing Issue</b>	MoEF	[Chainage]	4 kms	1. Proposal submitted to MoEF Letter sent by RO to MoEF nodal officer on [DD/MM/YYYY]	Escalate to higher level officers at MoEF	[DD/MM/YYYY]
2	<b>21 Cr compensation disbursement pending</b>	Land Acquisition	<b>Resolved</b>	[CALANAME]	[Chainage]	2.4 km	1. Escalated to chief secretary level through DO from Chairman / Secretary, dated [DD/MM/YYYY]		[DD/MM/YYYY]
3	<b>Slow progress by Contractor</b>	Contractor Issue	<b>New Issue</b>	[Concession Name]	[Chainage]	57 km	None	Project Director to call higher ups of Contractor	[DD/MM/YYYY]

### 3.2 Obligations as per Contract

#### Expected Contents & Structure

*Please write a summary of non-compliances of contractual obligations highlighting reasons for delay, stating pending actions and their potential risk to the project's progress and recommended actions by the IE.*

- ***Critical obligation sand constraints of Contractor as per contract***
- ***Critical obligations of Employer as per contract***
- ***Critical pending obligations of IE as per contract***

***NOTE: Please include important issues requiring intervention of various parties, giving details and background wherever necessary***

ALL FIGURES & GRAPHS IN TEMPLATES ARE ILLUSTRATIVE. PLEASE ADD ACTUAL DETAILS

#### 4 Physical Progress

Component	% Weightage	Physical Progress(During Current Month)	Physical Progress (Cumulative, Upto Current Month)
Road Works	35.00%	5%	15.0%
Major Bridge works and ROB / RUB	40.00%	1.20%	26.2%
Structures	21.00%	0.00%	0.8%
Other Works	4.00%	0.00%	0.0%
<b>Physical Progress</b>		<b>2%</b>	<b>42.0%</b>



ALL FIGURES & GRAPHS IN TEMPLATES ARE ILLUSTRATIVE. PLEASE ADD ACTUAL DETAILS

#### 4.1 Detailed Scope of Work & Physical Progress by Component

Component	Cost Weightage in Project (%)	Item Description	Cost Weightage in Component (%)	Planned in Scope (As per Scope of Work)	Progress till Date	%Physical Progress	Value of Physical Progress (7X4)
1	2	3	4	5	6	7	8
<b>1. Road works including culverts, minor bridges, underpasses, overpasses, approaches to ROB/RUB/ Major Bridges/ Structures (but excluding service roads)</b>	35.00%	1. C&G	5.00%	80 km	45 km	56%	2.8%
		2. Embankment	5.00%	80 km	40 km	50%	2.5%
		3. Sub Grade	5.00%	80 km	35 km	44%	2.2%
		4. GSB	5.00%	80 km	33 km	41%	2.1%
		5. WMM	5.00%	80 km	30 km	38%	1.9%
		6. DBM	5.00%	80 km	28 km	35%	1.8%
		7. BC	5.00%	80 km	27 km	34%	1.7%
<b>2. Major Bridge works and ROB/RUB</b>	40.00%	1. Major Bridges	10.00%	6 No	6 No	100%	10.0%
		2. Minor Bridges	5.00%	23 No	21 No	91%	4.6%
		3. Flyovers	5.00%	2 No	0	0%	0.0%
		4. ROB	5.00%	228 No	121 No	53%	2.7%
		5. VUP	5.00%	11 No	6 No	55%	2.7%
		6. PUP	5.00%	15 No	6 No	40%	2.0%
		7. RUB	5.00%	136 No	114 No	84%	4.2%
<b>3. Structures (elevated sections,</b>	21.00%	1. Foundation	5.00%	35 km	2.2 km	6%	0.2%
		2. Sub-structure	5.00%	35 km	2.1 km	6%	0.2%

reinforced earth)		3. Super-structure	5.00%	35 km	2.1 km	6%	0.2%
		4. Reinforced Earth Wall	6.00%	35 km	2.1 km	6%	0.2%
<b>4. Other Works</b>	4.00%	1. Toll Plaza	4.00%	4 No	0	0%	0.0%
<b>GRAND TOTAL</b>			<b>100%</b>				<b>42.0%</b>

## 5 Land Acquisition and Clearance

### 5.1 LA Summary

Description	Total Required (ha)	Total in possession at start (ha)	Total to be acquired (ha)
Existing ROW	135.00	135.00	0.00
Pvt. Land To be Acquired	240.00	0.000	240.00
Public Land To be Transferred	52.00	50.35	1.65
<b>Grand Total</b>	<b>427</b>	<b>185</b>	<b>242</b>

ALL FIGURES & GRAPHS IN TEMPLATES ARE ILLUSTRATIVE. PLEASE ADD ACTUAL DETAILS

### 5.2 LA Detail by CALA

CALA	Total Land left to be Acquired (Ha)	3H Pending (ha)	3H Done (ha)	3G Pending (ha)	3G Done (ha)	3D Pending (ha)	3DD Done (ha)	3A Pending (Ha)	3AD Done (ha)	Amount Awarded (Crore Rs.)	Amount Deposited (Crore Rs.)	Amount Disbursed by CALA (Crore Rs.)	Pending Amount (Crore Rs.)
CALA 1]	150	15	15	15	135	0	150	0	150	396	370	327	43
[CALA2]	67	0	0	0	67	0	67	0	67	132	132	120	23
[CALA3]	23	23	23	23	0	14	9	0	23	0	0	0	0
<b>Grand Total</b>	<b>240</b>	<b>38</b>	<b>202</b>	<b>38</b>	<b>202</b>	<b>14</b>	<b>226</b>	<b>0</b>	<b>240</b>	<b>528</b>	<b>502</b>	<b>447</b>	<b>66</b>

### 5.3 LA Detail by Village for each CALA

#### CALA 1

Village	Total Land left to be Acquired (Ha)	3H Pending (ha)	3H Done (ha)	3G Pending (ha)	3G Done (ha)	3D Pending (ha)	3D Done (ha)	3A Pending (Ha)	3A Done (ha)	Amount Awarded (Crore Rs.)	Amount Deposited (Crore Rs.)	Amount Disbursed by CALA (Rs Cr)	Pending Amount (Rs Cr)
[Village 1]	150	15	15	15	135	0	150	0	150	396	370	327	43
[Village 2]	67	0	0	0	67	0	67	0	67	132	132	120	23
[Village 3]	23	23	23	23	0	14	9	0	23	0	0	0	0
<b>Grand Total</b>	<b>240</b>	<b>38</b>	<b>202</b>	<b>38</b>	<b>202</b>	<b>14</b>	<b>226</b>	<b>0</b>	<b>240</b>	<b>528</b>	<b>502</b>	<b>447</b>	<b>66</b>

ALL FIGURES & GRAPHS IN TEMPLATES ARE ILLUSTRATIVE. PLEASE ADD ACTUAL DETAILS

### 5.4 Manpower details of CALA

CALA	Provided by <Agency / State Govt >	Amins / Surveyors	Patwaris / Village accountant	Revenue Inspectors / Kanungo	Tehsildars / Dep. Tehsildars	Clerks / Sahayaks	Accountants	Computer operators	Peons	Chain men	Total
[CALA 1]	<Agency >	4	1	0	0	3	0	3	1	0	12
[CALA 1]	State Govt	2	0	2	0	0	0	1	0	0	5
[CALA 2]	<Agency >										
[CALA 2]	State Govt										
<b>Grand Total</b>											

### 5.5 Clearances Summary

Environment				
Proposal Description	Status	Length Impacted	Current Stage	Issues/ Comments
Approval of construction in coastal zone	Obtained	Nil	Completed	

Forest Land				
Proposal Description	Status	Length Impacted	Current Stage	Issues/ Comments
Diversion of Xx ha ( <i>[Chainage]</i> )	Pending	<i>[Length in km]</i>	Completed	Stage 1 clearance pending
Diversion of Xx Ha. ( <i>[Chainage]</i> )	Obtained	Nil	Ongoing	

ALL FIGURES & GRAPHS IN TEMPLATES ARE ILLUSTRATIVE. PLEASE ADD ACTUAL DETAILS

Wildlife				
Proposal Description	Status	Length Impacted	Current Stage	Issues/ Comments
Diversion of Xx Ha. of forest land	Pending	<i>[Length in km]</i>	Ongoing	Queries sent to MoEF by RO, compliance pending
TreeCutting				
Proposal Description	Status	Length Impacted	Current Stage	Issues/ Comments
N.A.	N.A.	N.A.	N.A.	N.A.
Railway (ROBs/RUBs)				
Proposal Description	Status	Length Impacted	Current Stage	Issues/ Comments
<i>[GAD Number]</i>	Proposal Submitted, Approval pending	<i>[Chainage]</i>	Uploaded on portal on <i>[DD/MM/YYYY]</i>	N.A.

### 5.6 Status of utilities shifting

Utility Category	Name	Status	Length affected	Department	Date of request by Authority for estimate	Date when Estimate was Received from concerned dept.	Date of Approval by Authority RO/ HQ	Date of Deposit of supervision charge	Progress of Physical Shifting	Date of Certification from Agency for Completion	Estimate Amount	Issued
Water		Estimate Approved	[Length in km]	[DEPARTMENT]	[DD/MM/YYYY]	[DD/MM/YYYY]	[DD/MM/YYYY]	[DD/MM/YYYY]	Not started	TBD		
Electricity		Estimate Approved	[Length in km]	[DEPARTMENT]	[DD/MM/YYYY]	[DD/MM/YYYY]	[DD/MM/YYYY]	[DD/MM/YYYY]	Not started	TBD		
Others		Estimate Approved	[Length in km]	[DEPARTMENT]	[DD/MM/YYYY]	[DD/MM/YYYY]	[DD/MM/YYYY]	[DD/MM/YYYY]		TBD		

### 6 Change of Scope

S No.	Proposal Details	Date of first submission to AE	Current Status	COS Amount	ed/ Actual Date of Approval
1	Construction of [Flyover Name] at [Chainage]	[DD/MM/YYYY]	Approved in principle by Employer/IE/NHAI. Detailed quantities in proper order yet to be submitted	[+/- Amount]	[DD/MM/YYYY]
2	Nallah diversion through box culvert at [Chainage]	[DD/MM/YYYY]	Clarifications to be submitted by Contractor, expected date [DD/MM/YYYY]	[+/- Amount]	[DD/MM/YYYY]

### 7 Mobilization of Resources

S No.	Equipment Name	Make	Model	Age of Equipment	Planned / Required Quantity	Actual Quantity	Deployed During the Month	Reason(s) for Under/Over Mobilization	Expected Delay due to Under-Mobilization	Remarks
-------	----------------	------	-------	------------------	-----------------------------	-----------------	---------------------------	---------------------------------------	--	---------

Excavator/ Poclair					5				
Paver					2				
Transit Meter					0				
Plate Compactor s					0				
[ADD OTHERS]									

## 8 Financial Progress Details (for PPP projects)

### 8.1 Pen Picture - Escrow

TPC (Cr)	Cumulative inflow to Escrow till previous month (Cr)	Cumulative outflow from Escrow till previous month(Cr)	Inflow to Escrow during the month (Cr)	Outflow from Escrow during the month(Cr)
1,206	1,033	900	30	35

Are the Escrow withdrawals in accordance with the order of withdrawal as specified in the Contract Agreement?

*Tick as applicable*

If not, details to be provided below:

ALL FIGURES & GRAPHS IN TEMPLATES ARE ILLUSTRATIVE. PLEASE ADD ACTUAL DETAILS

### 8.2 Escrow details

TPC (Cr)	Cumulative exp. date till (Cr)	Escrow Plan till date- Debt (BOT)(Cr)	Escrow Plan till date- Equity (BOT) (Cr)	Escrow Plan till date- VGF (BOT) (Cr)	Escrow Actual till date- Debt (BOT) (Cr)	Escrow Actual till date- Equity (BOT) (Cr)	Escrow Actual till date- VGF (BOT) (Cr)

PLEASE EXCLUDE OUTSTANDING MOBILIZATION FEE/ ADVANCE IN S-CURVE

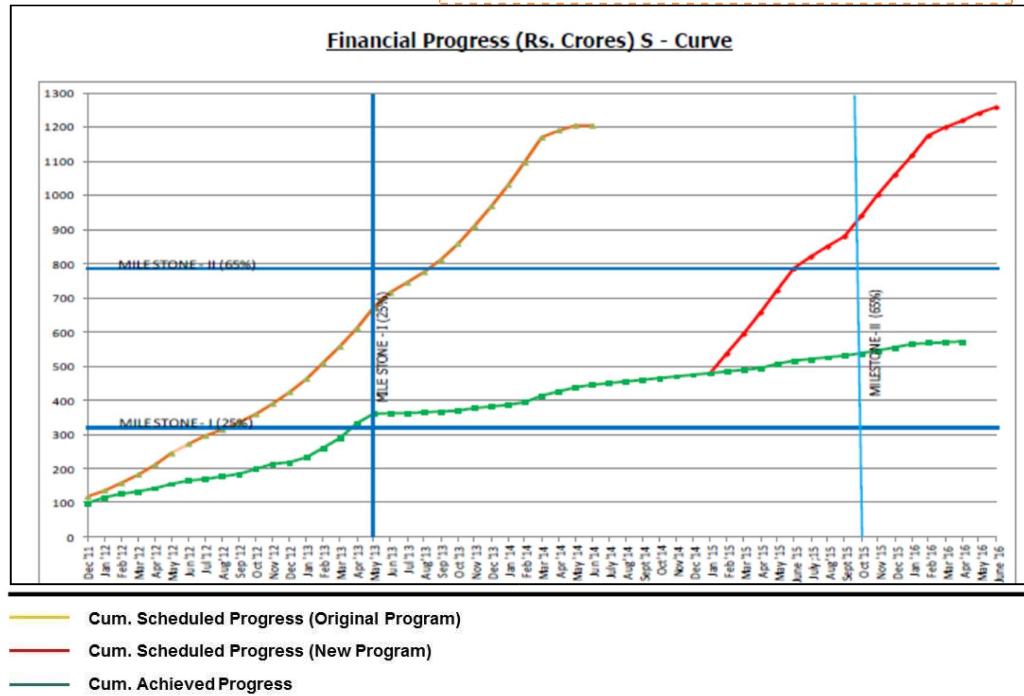

1,206	1,033	900	306	-	769	264	-
-------	-------	-----	-----	---	-----	-----	---

**9 Summary of quality control tests**

**9.1 Tests witnessed by IE/ CSE**

Description	Frequency of tests		Unit	Total test up to Previous Month			Total test in This Month			Cumulative No. of tests			Remarks
	No. s	Qty.		Conducte d	Pass	Fa il	Conducte d	Pass	Fa il	Conducte d	Pass	Fa il	
<b>Sub grade</b>													
Procter test	1	1500	m3	0	0	0	0	0	0	0	0	0	
Atterberg Limits	1	1500	m3	0	0	0	0	0	0	0	0	0	
Free Swell Index	1	1500	m3	0	0	0	0	0	0	0	0	0	

Description	Frequency of tests		Unit	Total test up to Previous Month			Total test in This Month			Cumulative No. of tests			Remarks
	No. s	Qty.		Conducte d	Pa ss	Fa il	Conducte d	Pa ss	Fa il	Conducte d	Pa ss	Fa il	
Grain Size Analysis	1	1500	m3	0	0	0	0	0	0	0	0	0	
C.B.R	1	3000	m3	0	0	0	0	0	0	0	0	0	
<b>Granular Sub Base</b>													
Gradation	1	200	m3	151	151	0	5	5	0	156	156	0	
Atterberg Limits	1	200	m3	151	136	15	5	5	0	151	136	15	
Procter test	1	1500	m3	0	0	0	0	0	0	0	0	0	
<b>Wet Mix Macadam</b>													
<b>Filter material</b>													
<b>Concrete</b>													
<b>Cement</b>													
<b>Water</b>													
<b>Prime Coat</b>													
<b>Tack coat</b>													
<b>Dense Bituminous Macadam</b>													
<b>Bituminous Concrete</b>													
<b>Bitumen test</b>													
<b>DLC</b>													
<b>Steel</b>													



## 9.2 Tests conducted by IE / CSE

*<Quality inspection test results to be reported in a table similar to the table provided in previous section>*

ALL FIGURES & GRAPHS IN TEMPLATES ARE ILLUSTRATIVE. PLEASE ADD ACTUAL DETAILS

## 10 Monitoring of maintenance obligations during construction phase

### 10.1 Critical issues and action log

SNo	Issue Descripti	Ongoing/Ne Issue	Concerne Authority	Chainage(s) affected due the issue	Length affecte km	Action(s) take till now	Action(s) suggested by :	Expected Date resolving issu
1	Drying up of plants on median	Ongoing	Contractor	325+200 to 327+800	2.6	Irregular watering	Replacemen t of plants and daily watering	NA
2	Large potholes	New	Contractor	387+300 LHS	0.1	None	Filling of potholes	<DD/MM >

### 10.2 Summary of repair work

S. No	Description	Unit	Total	Work done upto previous month	Work done during reporting month	Balance	Remark s
<b>1</b>	<b>Carriageway and paved shoulders</b>						
(a)	Pot Holes	Sqm	42	-	-	42	
(b)	Roughness value exceeding 2,500mm	mm					
(c)	Cracking in more than 5% of road surface	Sqm	7179	-	-	7179	
(d)	Rutting exceeding 10mm in more than 2% of road surface	Sqm	5	-	-	5	
(e)	Bleeding/Skiding	Sqm					
(f)	Ravelling	Sqm					

S. No	Description	Unit	Total	Work done upto previous month	Work done during reporting month	Balance	Remarks
(g)	Damage to pavement edges exceeding 10cm	m					
<b>2</b>	<b>Hard/Earth Shoulders</b>						
(a)	Rain cuts/ gullies in slope	Cum	650	25	-	625	
(b)	Edge drop at shoulders exceeding 40 mm	m					
<b>3</b>	<b>Drains and culverts</b>						
(a)	Cleaning of Culvert	Nos	1	-	-	1	
(b)	Damage to or silting of culverts						
(c)	Silting of drains in urban/ semi urban areas						
<b>4</b>	<b>Road furniture</b>						
(a)	Sign Boards	Nos	456	-	-	456	
(b)	Kilometer Stones						
(c)	Metal Beam Crash Barrier						
(d)	Bus Shelters	Nos	72	4	-	68	
(e)	Junction signs	Nos	26	8	-	18	
(f)	Median Grills	Rmt	894	-	-	894	
(g)	Studs	Nos	5328	-	-	5328	
(h)	Delinators	Nos	8236	-	-	8236	
(i)	Road Marking	Sqm	1899	-	-	1899	
(j)	Kerb Painting	Sqm	4575	-	-	4575	
(k)	Guard Posts	Nos	3657	-	-	3657	

S. No	Description	Unit	Total	Work done upto previous month	Work done during reporting month	Balance	Remarks
<b>5</b>	<b>Street lighting and telecom (ATMS)</b>						
(a)	Street lights	Nos					
(b)	Telecom	Nos					
<b>6</b>	<b>Trees and plantation</b>						
(a)	Removal of vegetation affecting sight line and road structures	Ha	77.42	-	3.57	73.85	
(b)	Replacement of trees and bushes	Nos	15072	-	-	15072	
<b>7</b>	<b>Buildings and bridges</b>						
(a)	Rest areas						
(b)	Toll plazas						
(c)	Bridges						

### 10.3 Status of damages

SNo	Period	Amount of damages (Rs)
1	Upto June 2016	
2	Jul 2016	
3	Aug 2016	
4	Sep 2016	
	<b>Total</b>	

## 11 Safety features

### 11.1 Pen picture of safety features

Details to be provided after assessment of the site requirement vis-à-vis provisions in the Contract Agreement:

Location of Black Spots	Suggested Remedial Measures within provisions of Contract Agreement	Additional Remedial Measures (if any)	Financial implications of additional Remedial Measures for Employer (Cr.)

### 11.2 Accident Report

S No	Date	Chainage r	Time of accide	Sex (M/F)	A	B	C	D	E	F	G	H	I	J	K	No of affected persons			Help provided
					Accident locati	Nature of accidr	Classification accident	Cause:	Load conditions vehicle	Road conditio	Intersection type control	Weather conditi	Age of victi	Type of victi	Type of vehic	Fatal	Major	Minor	
1	1/1/17	382/050 RHS	05:25 pm	M	2	2	3	4	1	1	-	1	3	1	3	-	1	1	Ambu

### Mapping of report fields to responses

A	1. Urban 2. Rural
B	1. Overtuned 2. Head On Collision 3. Hit from Back 4. Hit to Fix Object 5. Right turn Collision 6. Left turn Collision 7. Veered Out off The Road 8. Hit Pedestrian 9. Unknown/Hit & Ran Away
C	1. Fatal 2. Major injury 3. Minor injury
D	1. Drunken 2. Over Speeding 3. Vehicle out of Control 4. Driven on wrong side 5. Mechanical Problem 6. Drowsiness/Not Applicable 7. Fault of Driver
E	1. Normally Loaded 2. Overloaded/Handing 3. Empty 4. Unknown
F	1. Straight road 2. Slight Curve 3. Sharp Curve 4. Hump 5. Dip
G	1. T-Junction 2. Y-Junction 3. Four arm Junction 4. Staggered Junction 5. Junction with more than 6. Round about
H	1. Fine/Clear 2. Mist/Fog 3. Cloudy 4. Light Rain 5. Heavy Rain 6. Strong Wind 7. Dust Storm 8. Cold 9. Hot
I	1. 0-18 Years 2. 18-25 Years 3. 25-40 Years 4.40-60 Years 5. 60-80 Years
J	1. Driver 2. Passenger 3. Pedestrian 4. Cyclist 5. Others
K	1. Two Wheeler 2. Auto Rickshaw 3. Car/Jeep 4. Bus 5. Light Truck 6. Heavy Truck 7. Tractor 8. Bicycle 9. Cycle Rickshaw 10. Hand Drawn Cart 11. Animal Drawn Cart

## 12 Annexures

### Annex 1. Detailed List of Physical Components as per Schedule G

Component	Physical Item
<b>Road works including culverts, minor bridges, underpasses, overpasses, approaches to ROB/RUB/ Major Bridges/ Structures (but excluding service roads)</b>	<b>A- Widening and strengthening of existing road</b>
	(1) Earthwork up to top of the sub-grade
	(2) Granular work (sub- base, base, shoulders)
	(a) GSB
	(b) WMM
	(3) Shoulders
	(4) Bituminous work
	(a) DBM
	(b) BC
	(5) Rigid Pavement
	Concrete work
	(6) Widening and repair of culverts
	(7) Widening and repair of minor bridges
	<b>B- New realignment/bypass</b>
	<b>(1) Earthwork up to top of the sub-grade</b>
	(2) Granular work (sub- base, base, shoulders)
	(a) GSB
	(b) WMM
	(3) Shoulders
	(4) Bituminous work
	(a) DBM
	(b) BC
	(5) Rigid Pavement
	Concrete work
	<b>C-New culverts, minor bridges, underpasses, overpasses on existing road, realignments, bypasses:</b>
	(1) Culverts
	(2) Minor bridges
	(a) Foundation
	(b) Sub-structure
	(c) Super-structure (including crash barriers etc. complete)
(3) Cattle/Pedestrian underpasses	
(a) Foundation	
(b) Sub-structure	

Component	Physical Item
	(c) Super-structure (including crash barriers etc. complete) (4) Pedestrian overpasses (a) Foundation (b) Sub-structure (c) Super-structure (including crash barriers etc. complete)
	(5) Grade separated structures (a) Underpasses (i) Foundation (ii) Sub-structure (iii) Super-structure (including crash barriers etc. complete) (b) Overpass (i) Foundation (ii) Sub-structure (iii) Super-structure (including crash barriers etc. complete) (c) Flyover (i) Foundation (ii) Sub-structure (iii) Super-structure (including crash barriers etc. complete) (d) Foot over Bridge
<b>Major Bridge works and ROB/RUB</b>	<b>A- Widening and repairs of Major Bridges</b> (1) Foundation (a) Open Foundation (b) Pile Foundation/Well Foundation (2) Sub-structure (3) Super-structure (including crash barriers etc. complete) <b>B- Widening and repair of</b> (a) ROB (1) Foundation (2) Sub-structure (3) Super-structure (including crash barriers etc. complete) (b) RUB (1) Foundation (2) Sub-structure (3) Super-structure (including crash barriers etc. complete) <b>C- New Major Bridges</b> (1) Foundation (a) Open Foundation



Component	Physical Item
	(b) Pile Foundation/Well Foundation
	(2) Sub-structure
	(3) Super-structure (including crash barriers etc. complete)
	<b>D- New rail-road bridges</b>
	(a) ROB
	(1) Foundation
	(2) Sub-structure
	(3) Super-structure (including crash barriers etc. complete)
	(b) RUB
	(1) Foundation
	(2) Sub-structure
	(3) Super-structure (including crash barriers etc. complete)
	<b>Structures (elevated sections, reinforced earth)</b>
<b>(2) Sub-structure</b>	
<b>(3) Super-structure (including crash barriers etc. complete)</b>	
<b>(4) Reinforced Earth Wall (includes Approaches of ROB, Underpasses, Overpasses, Flyover etc.</b>	
<b>Other Works</b>	<b>(i) Service roads/ Slip Roads</b>
	<b>(ii) Toll Plaza</b>
	<b>(iii) Road side drains</b>
	<b>(iv) Road signs, markings, km stones, safety devices, ....</b>
	<b>(a) Road signs, markings, km stones, ....</b>
	<b>(b) Concrete Crash Barrier/ W-Beam Crash Barrier in Road work</b>
	<b>(v) Project facilities</b>
	(a) Bus bays
	(b) Truck lay-byes
	(c) Rest areas
	<b>(vi) Repairs to bridges/structures</b>
	<b>(vii) Road side plantation</b>
	<b>(viii) Protection works</b>
	(a) Boulder Pitching on slopes
	(b) Toe/Retaining wall
	<b>(ix) Tunnel</b>
	(a) Excavation
	(b) Construction of support system including rock bolting, lining etc.
	(c) On complete completion of tunnel

Component	Physical Item
	<b>(x) Miscellaneous</b>

\* The above list is illustrative and may require modification as per the actual scope of the work

## **Annex 2. Onwards**

IE / CSE should include comments, status update, data points and reports in following annexures which have not been included elsewhere in the main report. Such reports may include but not limited to:

- Review status of drawings/ design reports
- Review status of other documents
- Minutes of review meeting
- Detailed Inspection report of project highway
- Correspondence details
- Weather report
- Organizational chart of Contractor / Contractor and IE / CSE
- List of lab equipment
- Details of user complaints
- Project photographs

**Annexure VII: Output Format From Network Survey Vehicle And FWD Testing  
Deleted**

## SECTION 7: DRAFT FORM OF CONTRACT

**Note:** This draft Agreement is a generic document and shall be modified based on particular of the Project.

**CONTRACT FOR CONSULTANT'S SERVICES**

Between

---

(Name of Client)

And

---

(Name of Consultant)

Dated:

## CONTENTS

Page No.

<b>I.</b>	<b>FORM OF CONTRACT .....</b>
<b>II</b>	<b>GENERALCONDITIONSOFCONTRACT .....</b>

### **1. General Provisions .....**

1.1	Definitions
1.2	Relation between the Parties
1.3	Law Governing the Contract
1.4	Language
1.5	Headings
1.6	Notices
1.7	Location
1.8	Authority of Member in charge
1.9	Authorized Representatives
1.10	Taxes and Duties

### **2. Commencement, Completion, Modification, and Termination of Contract**

2.1	Effectiveness of Contract .....
2.2	Termination of Contract for Failure to Become Effective
2.3	Commencement of Services
2.4	Expiration of Contract
2.5	Entire Agreement
2.6	Modification
2.7	Force Majeure
2.7.1	Definition.....
2.7.2	No Breach of Contract .....
2.7.3	Measures to be taken
2.7.4	Extension of Time
2.7.5	Payments
2.7.6	Consultation
2.8	Suspension.....
2.9	Termination .....
2.9.1	By the Client .....
2.9.2	By the Consultants .....
2.9.3	Cessation of Rights and Obligations .....
2.9.4	Cessation of Services .....
2.9.5	Payment upon Termination .....
2.9.6	Disputes about Events of Termination .....

<b>3.</b>	<b>Obligations of the Consultants .....</b>
3.1	General
3.1.1	Standard of Performance.....
3.1.2	Law Governing Services .....
3.2	Conflict of Interests .....
3.2.1	Consultants not to Benefit from Commissions, Discounts, etc.
3.2.2	Procurement Rules of Funding Agencies
3.2.3	Consultants and Affiliates Not to Engage in certain Activities
3.2.4	Prohibition of Conflicting Activities ...
3.3	Confidentiality .....
3.4	Liability of the Consultants .....
3.5	Insurance to be Taken out by the Consultants ...
3.6	Accounting, Inspection and Auditing .....
3.7	Consultant's Actions requiring Client's prior Approval
3.8	Reporting Obligations .....
3.9	Documents prepared by the Consultants to Be the Property of the Client .....
3.10	Equipment and Materials Furnished by the Client
<b>4.</b>	<b>Consultants' Personnel and Sub-consultants .....</b>
4.1	General .....
4.2	Description of Personnel .....
4.3	Approval of Personnel .....
4.4	Working Hours, Overtime, Leave etc.
4.5	Removal and /or Replacement of Personnel .....
4.6	Resident Team Leader and Coordinator .....
<b>5.</b>	<b>Obligations of the Client .....</b>
5.1	Assistance and Exemptions .....
5.2	Access to Land .....
5.3	Change in the Applicable Law .....
5.4	Services, Facilities and Property of the Client
5.5	Payment .....
5.6	Counterpart Personnel.....
<b>6.</b>	<b>Payments to the Consultants .....</b>
6.1	Cost Estimates, Ceiling Amount .....
6.2	Remuneration and Reimbursable Expenditures...
6.3	Currency of Payment .....
6.4	Mode of Billing and Payment .....
<b>7.</b>	<b>Fairness and Good Faith</b>
7.1.	Good Faith
7.2.	Operation of the Contract

## **8. Settlement of Disputes**

- 8.1. Amicable Settlement
- 8.2. Dispute Settlement
- 8.3. Conciliation
- 8.4. Arbitration

## **9. Fake CV**

### **III SPECIAL CONDITIONS OF CONTRACT .....**

### **IV APPENDICES**

- Appendix A : Description of the Services .....
- Appendix B : Reporting Requirements .....
- Appendix C : Key Personnel and Sub-consultants
- Appendix D : Medical Certificate .....
- Appendix E : Hours of Work for Key Personnel .....
- Appendix F : Duties of the Client .....
- Appendix G : Cost Estimates
- Appendix H : Form of Performance Bank Guarantee
- Appendix I : Form of Bank Guarantee for Advance Payments
- Appendix J : Letter of invitation
- Appendix K : Letter of Award
- Appendix L : Minutes of pre-bid meeting .....
- Appendix-M : Memorandum of Understanding (in case of JV)

### **V ANNEXURES.....**



## 1. FORM OF CONTRACT

### COMPLEX TIME BASED ASSIGNMENTS

This CONTRACT (hereinafter called the "Contract") is made the \_\_\_\_ day of the Month of \_\_\_\_\_, 201\_\_, between, on the one hand \_\_\_\_\_ (hereinafter Called the "Client) and, on the other hand \_\_\_\_\_ hereinafter called the "Consultants")

*[Note\*: If the Consultants consist of more than one entity, the above should be partially amended to read as follows:*

*"...(hereinafter called the "Client") and, on the other hand, a joint venture consisting of the following entities, each of which will be jointly severally liable to the Client for all the Consultants' obligations under this Contract, namely, \_\_\_\_\_ and \_\_\_\_\_ (hereinafter called "Consultants")]*

### WHEREAS

- (a) the Client has requested the Consultants to provide certain consulting services as defined in the General Conditions of Contract attached to this Contract (hereinafter called the "Services");
- (b) the Consultants, having represented to the Client that they have the required professional skills ,and personnel and technical resources ,have agreed to provide the Services on the terms and conditions set forth in this Contract;

NOW THEREFORE the parties hereto hereby agree as follows:

- 1. The following documents attached hereto shall be deemed to form an integral part of this Contract:
  - (a) The General Conditions of Contract (hereinafter called "GC")'
  - (b) The Special Conditions of Contract (hereinafter called "SC"); (c) The following Appendices:

[Note: If any of these Appendices are not used, the words "Not Used" should be inserted below next to the title of the Appendix on the sheet attached hereto carrying the title of that Appendix ]-

- Appendix A : Description of the Services**
- Appendix B : Reporting Requirements**
- Appendix C : Key Personnel and Sub-consultants**
- Appendix D : Medical Certificate**

- Appendix E : Hours of Work for Key Personnel**
- Appendix F : Duties of the Client**
- Appendix G : Cost Estimates**
- Appendix H : Form of Performance Bank Guarantee**
- Appendix I : Form of Bank Guarantee for Advance Payments**
- Appendix J : Letter of invitation**
- Appendix K : Letter of Award**
- Appendix-L : Minutes of pre-Bid Meeting**
- Appendix-M : Memorandum of Understanding (in case of JV)**

2. The mutual rights and obligations of the Client and the Consultants shall be as set forth in the Contract; in particular
- (a) The Consultants shall carry out the Services in accordance with the provisions of the Contract; and
  - (b) The Client shall make payments to the Consultants in accordance with the Provisions of the Contract.

IN WITNESS WHEREOF, the Parties hereto have caused this Contract to be signed in their respective names as of the day and year first above written.

FOR AND ON BEHALF OF  
 [NAME OF THE CLIENT]  
 By  
 (Authorized Representative)

FOR AND ON BEHALF OF  
 [NAME OF THE CONSULTANTS]  
 By  
 (Authorized Representative)

[Note: If the Consultants consist of more than one entity, all of these entities should appear as signatures, e.g. in the following manner]

FOR AND ON BEHALF OF EACH OF  
 THE MEMBERS OF THE CONSULTANTS

[Name of the Member]  
 By  
 (Authorized Representative)

*[Name of the Member]*

By (Authorized Representative)



## **GENERAL CONDITIONS OF CONTRACT**

### **1. General Provisions**

Unless the context otherwise requires, the following terms whenever used in this Contract have the following meanings:

#### **1.1 Definitions**

- (a) "Applicable Law" means the laws and any other instruments having the force of law in the Government's country [or in such other country as may be specified in the Special Conditions of Contract (SC)], as they may be issued and in force from time to time.
- (b) "Contract" means the Contract signed by the Parties, to which these General Conditions of Contract are attached, together with all the documents listed in Clause 1 of such signed Contract;
- (c) "Effective Date" means the date on which this Contract comes into force and effect pursuant to Clause GC 2.1;
- (d) 'foreign currency' means any currency other than the currency of the Government;
- (e) 'GC' means these General Conditions of Contract;
- (f) "Government" means the Government of Client's Country;
- (g) 'Local currency' means the Indian Rupees;
- (h) "Consultant" wherever mentioned in this Contract Agreement means the "Project Management Consultant (PMC)" and includes sub-consultants or Associates engaged by the primary consultant.
- (i) "Member", in case the Consultants consist of a joint venture of more than one entity, means any of these entities, and "Members" means all of these entities;
- (j) "Party" means the Client or the Consultants, as the case may be, and Parties means both of them;
- (k) "Personnel" means persons hired by the Consultants or by any SubConsultants and or Associates as Employees and assigned to the performance of the Services

Or any part thereof; "Foreign Personnel" means such persons who at the time of being so hired had their domicile outside the Government's Country, "Local Personnel" means such persons who at the time of being so hired had their domicile inside the Government's Country; and 'key personnel' means the personnel referred to in Clause GC 4.2 (a).

- (l) "SC" means the Special Conditions of Contract by which these General Conditions of Contract may be amended or supplemented;
- (m) "Services" means the work to be performed by the Consultants pursuant to his contract, as described in Appendix A hereto. The scope of work will be strictly as given in various Clauses in TOR. The approach and methodology to be

adopted by the Consultant for carrying out the assignment as Project Management Consultant may be modified depending on the site requirements and work programme of the EPC Contract or after mutual discussions with Employer, the EPC Contractor and the Construction Supervision Engineer. The work plan as indicated by the Consultant may be modified accordingly to the site requirements.

- (n) "Sub-Consultant and or Associates "means any entity to which the Consultants subcontract any part of the Services in accordance with the provisions of Clause GC 3.7; and
- (o) "Third Party" means any person or entity other than the Government, the Client, the Consultants or a Sub-consultant.

## **1.2 Relation between the Parties**

Nothing contained herein shall be construed as establishing a relation of master and servant or of principal and agent as between the Client and the Consultants. The Consultants, subject to this Contract, have complete charge of Personnel and Sub-consultants, if any, performing the Services and shall be fully responsible for the Services performed by them or on their behalf hereunder.

## **1.3 Law Governing Contract**

This Contract, its meaning and interpretation, and the relation between the Parties shall be governed by the Applicable Law.

## **1.4 Language**

This Contract has been executed in the language specified in the SC, which shall be the binding and controlling language for all matters relating to the meaning or interpretation of this Contract.

## **1.5 Headings**

The headings shall not limit, alter or affect the meaning of this Contract.

## **1.6 Notices**

1.6.1 Any notice, request or consent required or permitted to be given or made pursuant to this Contract shall be routed through BAEL email unless the law requires to send such notice, request, send such notice, request, etc., through physical/ any other specified mode only. Any such notice, request or consent shall be deemed to have been delivered when given or made on the BAEL email to an authorized representative of the party specified in the SC.

1.6.2 Notice will be deemed to be effective as specified in the SC.

1.6.3 A Party may change its address for notice hereunder by giving the other Party notice of such change pursuant to the provisions listed in the SC with respect to Clause GC 1.6.2.

## **1.7 Location**

The Services shall be performed at such locations as are specified in Appendix A hereto and, where the location of a particular task is not so specified, at such locations whether in Government's Country or elsewhere, as the Client may approve.

## **1.8 Authority of Member in Charge**

In case the Consultants consist of a joint venture of more than one entity, the Members hereby authorize the entity specified in the SC to act on their behalf in exercising all the Consultants' rights and obligations towards the Client under this Contract, including without limitation the receiving of instructions and payments from the Client.

## **1.9 Authorized Representatives**

Any action required or permitted to be taken, and any document required or permitted to be executed, under this Contract by the Client or the Consultants may be taken or executed by the officials specified in the SC.

## **1.10 Taxes and Duties**

Unless otherwise specified in the SC, the Consultants, Sub-consultants and Personnel shall pay such taxes, duties, fees and other impositions as may be levied under the Applicable Law. Goods & Service tax as applicable shall be paid to the Project Management Consultant while making payment for services rendered. The consultants shall then deposit the same with the tax authorities and provide a proof of having done so within next 90 days in line with policy circulars issued by Employer.

## **2. Commencement, Completion, Modification and Termination of Contract**

### **2.1 Effectiveness of Contract**

This Contract shall come into force and effect on the date (the "Effective Date") of the Client's notice to the Consultants instructing the Consultants to begin carrying out the Services. This notice shall confirm that the effectiveness conditions, if any, listed in the SC have been met.

### **2.2 Termination of Contract for Failure to Become Effective**

If this Contract has not become effective within such time period after the date of the Contract signed by the Parties as shall be specified in the SC, either Party may, by not less than four (4) weeks' written notice to the other Party, declare this Contract to be null and void, and in the event of such a declaration by either Party, neither Party shall have any claim against the other Party with respect hereto.

### **2.3 Commencement of Services**

The Consultants shall begin carrying out the Services at the end of such time period after the Effective Date as shall be specified in the SC.

## **2.4 Expiration of Contract**

Unless terminated earlier pursuant to Clause GC2.9 hereof, this Contract shall expire when services have been completed and all payments have been made at the end of such time period after the Effective Date as shall be specified in the SC.

## **2.5 Entire Agreement**

This Contract contains all covenants, stipulations and provisions agreed by the Parties. No agent or representative of either Party has authority to make, and the Parties shall not be bound by or be liable for, any statement, representation, promise or agreement not set forth herein.

## **2.6 Modification**

Modification of the terms and conditions of this Contract, including any modification of the scope of the Services, may only be made by written agreement between the Parties as the case may be, has been obtained. Pursuant to Clause GC 7.2 hereof, however, each Party shall give due consideration to any proposals for modification made by the other Party.

## **2.7 Force Majeure**

### **2.7.1. Definition**

- (a) For the purposes of this Contract, "Force Majeure" means an event which is beyond the reasonable control of a Party, and which makes a Party's performance of its obligations hereunder impossible or so impractical as reasonably to be considered impossible in the circumstances, and includes, but is not limited to, war, riots, civil disorder, earthquake, fire, explosion, storm, flood or other adverse weather conditions, strikes, lockouts or other industrial action ( except where such strikes, lockouts or other industrial action are within the power of the Party invoking Force Majeure to prevent), confiscation or any other action by government agencies.
- (b) Force Majeure shall not include (i) any event which is caused by the negligence or intentional action of a party or such Party's Sub-consultants or agents or employees, nor (ii) any event which a diligent Party could reasonably have been expected to both (A) take in to account at the time of the conclusion of this Contract and (B) avoid or overcome in the carrying out of its obligations hereunder .
- (c) Force Majeure shall not include insufficiency of funds or failure to make any payment required hereunder.

### **2.7.2 No Breach of Contract**

The failure of a Party to fulfill any of its obligations hereunder shall not be considered to be a breach of, or default under, this Contract insofar as such inability arises from an event of Force Majeure, provided that the Party affected by such an event has taken all reasonable

precautions, due care "and reasonable alternative measures, all with the objective of carrying out the terms and conditions of this Contract.

### **2.7.3 Measures to be taken**

- (a) A Party affected by an event of Force Majeure shall take all reasonable measures to remove such Party's inability to fulfill its obligations hereunder with a minimum of delay.
- (b) A Party affected by an event of Force Majeure shall notify the other Party of such event as soon as possible, and in any event not later than fourteen (14) days following the occurrence of such event, providing evidence of the nature and cause of such event, and shall similarly give notice of the restoration of normal conditions as soon as possible.
- (c) The Parties shall take all reasonable measures to minimize the consequences of any event of Force Majeure.

### **2.7.4 Extension of Time**

Any period within which a Party shall, pursuant to this Contract, complete any action or task, shall be extended for a period equal to the time during which such Party was unable to perform such action as a result of Force Majeure.

Extension of Time for providing services of the Project Management Consultant shall be extended concurrently with the Extension of Time granted, if any, to the EPC Contractor for the project, subject to satisfactory performance of the Project Management Consultant and limited to original period of consultancy services.

### **2.7.5 Payments**

During the period of their inability to perform the Services as a result of an event of Force Majeure, the Consultants shall be entitled to be reimbursed for additional costs reasonably and necessarily incurred by them during such period for the purposes of the Services and in reactivating the Services after the end of such period.

### **2.7.6 Consultation**

Not later than thirty (30) days after the Consultants, as the result of an event of Force Majeure, have become unable to perform a material portion of the Services, the Parties shall consult with each other with a view to agreeing on appropriate measures to be taken in the circumstances.

## **2.8. Suspension**

The Client may, by written notice of suspension to the Consultants, suspend all payments to the Consultants hereunder if the Consultants fail to perform any of their obligations under this Contract, including the carrying out of the Services, provided that such notice of suspension (i) shall specify the nature of the failure, and (ii) shall request the Consultants



to remedy such failure within a period not exceeding thirty (30) days after receipt by the Consultants of such notice of suspension.

## **2.9 Termination**

### **2.9.1 By the Client**

The Client may, by not less than thirty (30) days' written notice of termination to the Consultants (except in the event listed in paragraph (f) below, for which there shall be a written notice of not less than sixty (60) days), such notice to be given after the occurrence of any of the events specified in paragraphs (a) through (h) of this Clause GC 2.9.1, terminate this Contract.

- (a) if the Consultants fail to remedy a failure in the performance of their obligations hereunder, as specified in a notice of suspension pursuant to Clause GC 2.8 herein above, within thirty (30) days of receipt of such notice of suspension or within such further period as the Client may have subsequently approved in writing;
- (b) If the Consultants become (or, if the Consultants consist of more than one entity, if any of their Members becomes) in solvent or bankrupt or enter into any agreements with their creditors for relief of debt or take advantage of any law for the benefit of debtors or go into liquidation or receivership whether compulsory or voluntary;
- (c) If the Consultants fail to comply with any final decision reached as a result of arbitration proceedings pursuant to Clause GC 8 hereof;
- (d) If the Consultants submit to the Client a statement which has a material effect on the rights, obligations or interests of the Client and which the Consultants know to be false;
- (e) if, as the result of Force Majeure, the Consultants are unable to perform a material portion of the Services for a period of not less than sixty (60) days; or
- (f) if the Client, in its sole discretion and for any reason whatsoever, decides to terminate this Contract.
- (g) if the consultant, in the judgment of the Client has engaged in corrupt or fraudulent practices in competing for or in executing the Contract. For the purpose of this clause:

"corrupt practice" means the offering, giving, receiving or soliciting of anything of value to influence the action of a public official in the selection process or in contract execution.

"fraudulent practice" means a misrepresentation of facts in order to influence a selection process or the execution of a contract to the detriment of the Borrower, and includes collusive practice among consultants (prior to or after submission of proposals) designed to establish prices at artificial non-competitive levels and to deprive the Borrower of the benefits of free and open competition.

- (h) if EPC Contractor represents to Employer that the Consultant is not discharging his duties in a fair, efficient and diligent manner and if the dispute remains unresolved, Employer may terminate this contract.

### **2.9.2 By the Consultants**

The Consultants may, by not less than thirty (30) days' written notice to the Client, such notice to be given after the occurrence of any of the events specified in paragraphs (a) through (d) of this Clause GC2.9.2, terminate this Contract:

- (a) if the Client fails to pay any money due to the Consultants pursuant to this Contract and not subject to dispute pursuant to Clause 8 hereof within forty-five (45) days after receiving written notice from the Consultants that such payment is overdue;
- (b) if the Client is in material breach of its obligations pursuant to this Contract and has not remedied the same within forty-five (45) days (or such longer period as the Consultants may have subsequently approved in writing) following the receipt by the Client of the Consultants' notice specifying such breach;
- (c) if, as the result of Force Majeure, the Consultants are unable to perform a material portion of the Services for a period of not less than sixty (60) days; or
- (d) if the Client fails to comply with any final decision reached as a result of arbitration pursuant to Clause GC 8 hereof.

### **2.9.3. Cessation of Rights and Obligations**

Upon termination of this Contract pursuant to Clauses GC 2.2 or GC 2.9 hereof, or upon expiration of this Contract pursuant to Clause GC2.4 hereof, all rights and obligations of the Parties hereunder shall cease, except:

- (i) such rights and obligations as may have accrued on the date of termination or expiration;
- (ii) the obligation of confidentiality set forth in Clause GC 3.3 hereof;
- (iii) the Consultants' obligation to permit inspection, copying and auditing of their accounts and records set forth in Clause GC 3.6 (ii) hereof; and
- (iv) any right which a Party may have under the Applicable Law

### **2.9.4 Cessation of Services**

Upon termination of this Contract by notice of either Party to the other pursuant to Clauses GC2.9.1 or GC2.9.2 hereof, the Consultants shall, immediately upon dispatch or receipt of such notice, take all necessary steps to bring the Services to a close in a prompt and orderly manner and shall make every reasonable effort to keep expenditures for this purpose to a minimum. With respect to documents prepared by the Consultants and equipment and materials furnished by the Client, the Consultants shall proceed as provided, respectively, by Clauses GC 3.9 or GC 3.10 hereof.

## **2.9.5 Payment upon Termination**

Upon termination of this Contract pursuant to Clauses GC 2.9.1 or GC 2.9.2 hereof, the Client shall make the following payments to the Consultants (after offsetting against these payments any amount that may be due from the Consultant to the Client):

- (a) remuneration pursuant to Clause GC 6 hereof for Services satisfactorily performed prior to the effective date of termination;
- (b) reimbursable expenditures pursuant to Clause GC 6 hereof for expenditures actually incurred prior to the effective date of termination; and
- (c) except in the case of termination pursuant to paragraphs (a) through (d) of Clause GC2.9.1 hereof, reimbursement of any reasonable cost incident to the prompt and orderly termination of the Contract including the cost of their travel of the Consultants' personnel and their eligible dependents.

## **2.9.6. Disputes about Events of Termination**

If either Party disputes whether an event specified in paragraphs (a) through (e) of Clause GC 2.9.1 or in Clause GC2.9.2 hereof has occurred, such Party may, within forty-five (45) days after receipt of notice of termination from the other Party, refer the matter to arbitration pursuant to Clause GC8 hereof, and this Contract shall not be terminated on account of such event except in accordance with the terms of any resulting arbitral award.

## **3. Obligation of the Consultants**

### **3.1 General**

#### **3.1.1. Standard of Performance**

The Consultants shall perform the Services and carry out their obligations hereunder with all due diligence, efficiency and economy, in accordance with generally accepted professional techniques and practices, and shall observe sound management practices, and employ appropriate advanced technology and safe and effective equipment, machinery, materials and methods "The Consultants shall always" act, in respect of any matter relating to this Contract or to the Services, as faithful advisers to the Client, and shall at all times support and safeguard the Client's legitimate interests in any dealings with Subconsultants or Third Parties.

#### **3.1.2 Law Governing Services**

The Consultants shall perform the Services in accordance with the Applicable Law and shall take all practicable steps to ensure that any Sub-consultants and or Associates, as well as the Personnel of the Consultants and any Subconsultants and or Associates, comply with the Applicable Law. The Client shall advise the Consultants in writing of relevant local customs and the Consultants shall, after such notifications, respect such customs.

## **3.2 Conflict of Interests**

### **3.2.1 Consultants Not to Benefit from Commissions, Discounts, etc.**

The Remuneration of the Consultants pursuant to Clause GC6 hereof shall constitute the Consultants' sole remuneration in connection with this Contract or the Services and, subject to ClauseGC3.2.2 hereof, the Consultants shall not accept for their own benefit any trade commission, discount or similar payment in connection with activities pursuant to this Contract or to the Services or in the discharge of their obligations hereunder, and the Consultants shall use their best efforts to ensure that any Sub-consultants and or Associates, as well as the Personnel and agents of either of them, similarly shall not receive any such additional remuneration.

**3.2.2** If the Consultants, as part of the Services, have the responsibility of advising the Client on the procurement of goods, works or services, the Consultants shall comply with any applicable procurement guidelines of the Client (Employer)and or Associates Bank or of the Association, as the case maybe, and other funding agencies and shall at all times exercise such responsibility in the best interest of the Client. Any discounts or commissions obtained by the Consultants in the exercise of such procurement responsibility shall be for the account of the Client.

### **3.2.3 Consultants and Affiliates Not to engage in Certain Activities**

The Consultants agree that, during the term of this Contract and after its termination, the Consultants and any entity affiliated with the Consultants, as well as any Sub- Consultant and or Associates and any entity affiliated with such Sub Consultant and or Associates, shall be disqualified from providing goods works or services (other than the Services and any continuation thereof) for any project resulting from or closely related to the Services. .

### **3.2.4 Prohibition of Conflicting Activities**

The Consultants shall not engage, and shall cause their Personnel as well as their Sub-consultants and or Associates and their Personnel not to engage, either directly or indirectly, in any of the following activities:

- (a) during the term of this Contract, any business or professional activities in the Government's country which would conflict with the activities assigned to them under this Contract; and
- (b) after the termination of this Contract, such other activities as may be specified in the SC.

## **3.3 Confidentiality**

The Consultants, their Sub-consultants and the Personnel of either of them shall not, either during the term or within two (2) years after the expiration of this Contract, disclose any proprietary or confidential information relating to the Project, the Services, this Contract or the Client's business or operations without the prior written consent of the Client.

### **3.4 Liability of the Consultants**

Subject to additional provisions, if any, set forth in the SC, the Consultants' liability under this Contract shall be as provided by the Applicable Law.

### **3.5 Insurance to be Taken Out by the Consultants**

The Consultants (i) shall take out and maintain, and shall cause any Subconsultants to take out and maintain, at their (or the Sub-consultants', as the case may be) own cost but on terms and conditions approved by the Client, insurance against the risks, and for the coverages, as shall be specified in the SC, and (ii) at the Client's request, shall provide evidence to the Client showing that such insurance has been taken out and maintained and that the current premiums therefore have been paid.

### **3.6 Accounting, Inspection and Auditing**

The Consultants(i)shall keep accurate and systematic accounts and records in respect of the Services, hereunder, in accordance with internationally accepted accounting principles and in such form and detail as will clearly identify all relevant time charges and cost, and the bases thereof (including such bases as may be specifically referred to in the SC) ; (ii) shall permit the Client or its designated representative periodically, and upto one year from the expiration or termination of this Contract, to inspect the same and make copies thereof as well as to have them audited by auditors appointed by the Client; and (iii) shall permit the client to inspect the Consultant's accounts and records relating to the performance of the Consultant and to have them audited by auditors appointed by the client.

### **3.7 Consultants' Actions Requiring Client's Prior Approval**

The Consultants shall obtain the Client's prior approval in writing before taking any of the following actions:

- (a) appointing such members of the Personnel as are listed in Appendix 'C' ("Consultants' Sub-consultants' Key Personnel") merely by title but not by name;
- (b) entering into a subcontract for the performance of any part of the Services, it being understood (i) that the selection of the Sub-Consultant and the terms and conditions of the subcontract shall have been approved in writing by the Client prior to the execution of the subcontract, and (ii) that the Consultants shall remain fully liable for the performance of the Services by the Sub-Consultant and its Personnel pursuant to this Contract; and
- (c) any other action that may be specified in the SC

### **3.8 Reporting Obligations**

The Consultants shall submit to the Client the reports and documents specified in Appendix B here to, in the form, in the numbers and within the time periods set forth in the said Appendix.

### **3.9 Documents Prepared by the Consultants to Be the Property of the Client**

All plans, drawings, specifications, designs, reports, other documents and software prepared by the Consultants for the Client under this Contract shall become and remain the property of the Client, and the Consultants shall, not later than upon termination or expiration of this Contract, deliver all such documents to the Client, together with a detailed inventory thereof. The Consultants may retain a copy of such documents and software. Restrictions about the future use of these documents and software, if any, shall be specified in the SC.

### **3.10 Equipment and Materials Furnished by the Client**

Equipment and materials made available to the Consultants by the Client, or purchased by the Consultants with funds provided by the Client, shall be the property Of the Client and shall be marked accordingly. Upon termination or expiration of this Contract, the Consultants shall make available to the Client an inventory of such equipment and materials and shall dispose of- such equipment and materials in accordance with the Client's instructions. While in possession of such equipment and materials, the Consultants, unless otherwise instructed by the Client in writing, shall insure them at the expense of the Client in an amount equal to their full replacement value.

## **4. Consultants' Personnel and Sub-consultants and or Associates**

### **4.1 General**

The Consultants shall employ and provide such qualified and experienced Personnel and Sub-consultants as are required to carry out the Services.

### **4.2 Description of Personnel**

- (a) The titles, agreed job descriptions, minimum qualification and estimated periods of engagement in the carrying out of the Services of each of the Consultants' Key Personnel are described in Appendix C. If any of the Key Personnel has already been approved by the clients his/her name is listed as well.
- (b) If required to comply with the provisions of Clause GCC 3.1.1 hereof, adjustments with respect to the estimated periods "of engagement of Key Personnel set forth in Appendix C may be made by the Consultants by written notice to the Client, provided (i) that such adjustments shall not alter the originally estimated period of engagement of any individual by more than 10% or one week, whichever is larger, and (ii) that the aggregate of such adjustments shall not cause payments under this Contract to exceed the ceilings set forth in Clause GC 6.1(b) of this Contract. Any other such adjustments shall only be made with the Client's written approval.
- (c) If additional work is required beyond the scope of the Services specified in Appendix A, the estimated periods of engagement of Key Personnel set forth in Appendix C may be increased by agreement in writing between the Client and the

Consultants, provided that any such increase shall not, except as otherwise agreed, cause payments under this Contract to exceed the ceilings set for thin Clause GC 6.1 (b) of this Contract.

#### 4.3 Approval of Personnel

The Key Personnel i.e. Professional Staff and Sub-consultants listed by title as well as By name in Appendix C are hereby approved by the Client. In respect of other Key Personnel which the Consultants propose, to use in the carrying out of the Services, the Consultants shall submit to the client for review and approval a copy of their biographical data and (in the case of Key personnel to be used within the country of the Government) a copy of a satisfactory medical certificate in the form attached here to as Appendix D. If the Client does not object in writing (stating the reasons for the objection) within thirty (30) calendar days from the date of receipt of such biographical data and (if applicable) such certificate, such Key Personnel shall be deemed to have been approved by the Client.

#### 4.4 Working Hours, Overtime, Leave, etc.

- (a) Working hours and holidays for Key Personnel are set forth in Appendix E hereto. To account for travel time, foreign Personnel carrying out Services inside the Government's country shall be deemed to have commenced (or finished) work in respect of the Services such number of days before their arrival in (or after their departure from) the Government's country as is specified in Appendix E hereto.
- (b) The Personnel of all types engaged by Consultant to provide Services on this Contract shall not be entitled to be paid for overtime nor to take paid sick leave or vacation leave **except as specified in Appendix E** hereto, and except as specified. In such Appendix, the Consultants' remuneration shall be deemed to cover these items. All leave to be allowed to the Personnel is included in the staff-months of service set for in **Appendix C**. Any taking of leave by Personnel shall be subject to the prior approval by the Client and the Consultants shall ensure that absence for leave purposes will not delay the progress and adequate supervision of the Services.
- (c) All key personnel and sub professional staff of the Project Management Consultant shall use Aadhaar based biometric attendance/ geo – tagged selfie – based attendance system for making their daily attendance. Aadhaar based Biometric Attendance/ Geo – tagged selfie – based attendance system shall be marked at least once a day and any time during the day. 01 Aadhaar based biometric attendance/ geo – tagged selfie – based attendance system shall be installed by the Project Management Consultant at its own cost at the site office in order to facilitate the attendance marking. More systems can be installed near the project highway upto a maximum of 1 system per 50 km in order to encourage frequent visits of project highway by key personnel and sub professional staff. A copy of monthly Aadhaar based Biometric Attendance/ Geo – tagged selfie – based attendance shall be attached with Monthly Status Report. Proper justification shall be provided for cases of absence of key personnel/



sub professional staff which do not have prior approval from Project Director of concerned stretch. Project Management Consultant have to provide a certificate that all key personnel as envisaged in the Contract Agreement has been actually deployed in the project.

- (d) Project Management Consultant will intimate concerned Project Director/ Project Incharge immediately after establishing its site office regarding installation of Aadhaar based biometric attendance/ geo – tagged selfie – based attendance system and complete address of its site office.

#### **4.5 Removal and/or Replacement of Personnel**

Removal and/or replacement of Key Personnel shall be regulated as under:

- 4.5.1** In case notice to commence services pursuant to Clause 2.1 of this Contract is not ordered by Client within 120 days of signing of contract the key personnel can excuse themselves on valid grounds, e.g., selection on some other assignment, health problem developed after signing of contract, etc. In such a case no penalty shall be levied on the Firm or on the person concerned. The firm shall however be asked to give a replacement by an equal or better scoring person, whenever mobilization is ordered.
- 4.5.2** In case notice to commence services is given within 120 days of signing of contract the, the Employer expects all the Key Personnel specified in the Proposal to be available during implementation of the Agreement. The Employer will not consider any substitution of Key Personnel except under compelling circumstances beyond the control of the Consultant and the concerned Key Personnel. Such substitution shall be limited to not more than three Key Personnel subject to equally or better qualified and experienced personnel being provided to the satisfaction of the Employer. Replacement of the Team Leader will not normally be considered and may lead to disqualification of the Applicant or termination of the Agreement. Replacement of one Key Personnel shall be permitted subject to reduction of remuneration equal to 5 % (five per cent) of the total remuneration specified for the Key Personnel who is proposed to be replaced. In case of second replacement the reduction in remuneration shall be equal to 10% (ten per cent) and for third and subsequent replacement, such reduction shall be equal to 15% (fifteen per cent) If the consultant finds that any of the personnel had made false representation regarding his qualification and experience, he may request the Employer for replacement of the personnel. There shall be no reduction in remuneration for such replacement. The replacement shall however be of equal or better score. The personnel so replaced shall be debarred from future projects for 2 years.
- 4.5.3** In case, person permanently employed with the firm is to be replaced, technical score of both the CVs shall be compared excluding the marks given for employment with firm. Replacement would be allowed when the technical score (excluding the marks given for employment with firm) of the new key person is equal or better than the existing key person's technical score excluding marks assigned for permanent employment with the firm. However, the remuneration of such replacement shall be reduced on proportionate basis in case the overall score of the replacement person is less than the overall score of original person.



#### 4.5.4 Replacement after original contract period is over:

There shall be no limit on the replacements and no reduction in remunerations shall be made. The replacement shall however be of equal or better score.

4.5.5 If the Employer (i) finds that any of the Personnel has committed serious misconduct or has been charged with having committed a criminal action or (ii) has reasonable ground to be dissatisfied with the performance of any of the Personnel, then the consultant shall, at the Employer's written request specifying the grounds therefore, forthwith provide a replacement with qualifications and experience acceptable to him. For such replacement there will be no reduction in remuneration.

4.5.6 If any member of the approved team of a consultant engaged by Barwa Adda Expressway Limited (BAEL) leaves that consultant before completion of the job, he shall be barred for a period of 6 months to 24 months from being engaged as a team member of any other consultant working (or to be appointed) for any other Barwa Adda Expressway Limited (BAEL) projects.

4.5.7 Consultants shall submit the replacement proposal directly to the competent level responsible for such approvals. The approval for replacement of key personnel shall be accorded within one month of submission of such proposal. In case of further delay, unless refused after due evaluation of CV by the Employer within a month, it will be considered deemed approval of such replacements proposed.

#### 4.6 Resident Team Leader and Coordinator

The person designated as the Team Leader of the Consultant's Personnel shall be responsible for the coordinated, timely and efficient functioning of the Personnel. In addition, the Consultant shall designate a suitable person from its Head Office as Project Coordinator who shall be responsible for day to day performance of the Services.

### 5. Obligations of the Client

#### 5.1 Assistance and Exemptions

Unless otherwise specified in the SC, the Client shall use its best efforts to ensure that the Government shall:

- (a) provide the Consultants, Sub-consultants and Personnel with work permits and such other documents as shall be necessary to enable the Consultants, Sub-consultants or Personnel to perform the Services;
- (b) assist for the Personnel and, if appropriate, their eligible dependents to be provided promptly with all necessary entry and exit visas, residence permits, exchange permits and any other documents required for their stay in Government's country;
- (c) Facilitate prompt clearance through customs of any property required for the Services and of the personal effects of the Personnel and their -eligible dependents;

- (d) Issue to officials, agents and representatives of the Government all such instructions as may be necessary or appropriate for the prompt and effective implementation of the Services;
- (e) assist the Consultants and the Personnel and any Sub-consultants and or Associates employed by the Consultants for the Services from any requirement to register or obtain any permit to practice their profession or to establish themselves either individually or as a corporate entity according to the Applicable Law;
- (f) grant to the Consultants, any Sub-consultants and or Associates and the Personnel of either of them the privilege, pursuant to the Applicable Law, of bringing into Government's country reasonable amounts of foreign currency for the purposes of the Services or for the personal use of the Personnel and their dependents and of withdrawing any such amounts as may be earned therein by the Personnel in the execution of the Services: and
- (g) Provide to the Consultants, Sub-consultants and or Associates and Personnel any such other assistance as may be specified in the SC.

## **5.2 Access to Land**

The Client warrants that the Consultants shall have, free of charge, unimpeded access to all land in the Government's country in respect of which access is required for the performance of the Services. The Client will be responsible for any damage to such land or any property thereon resulting from such access and will indemnify the Consultants and each of the Personnel in respect of liability for any such damage, unless such damage is caused by the default or negligence of the Consultants or any Sub-Consultant or the Personnel of either of them.

## **5.3 Change in the Applicable Law**

If, after the date of this Contract, there is any change in the Applicable Law with respect to taxes and duties which increases or decreases the cost or reimbursable expenses incurred by the Consultants in performing the Services, then the remuneration and reimbursable expenses otherwise payable to the Consultants under this Contract shall be increased or decreased accordingly by agreement between the Parties hereto, and corresponding adjustments shall be made to the ceiling amounts specified in Clause GC 6.1(b).

## **5.4 Services, Facilities and Property of the Client**

The Client shall make available to the Consultants and the Personnel, for the purposes of the services and free of any charge, the services, facilities and property described in Appendix F at the times and in the manner specified in said Appendix F, provided that if such services, facilities and property shall not be made available to the Consultants as and when so specified, the Parties shall agree on (i) any time extension that it may be appropriate to grant to the Consultants for the performance of the Services, (ii) the manner in which the Consultants shall procure any such services, facilities and property from other

sources, and (iii) the additional payments, if any, to be made to the Consultants as a result thereof pursuant to Clause GC 6.1(c) hereinafter.

## **5.5 Payment**

In consideration of the Services performed by the Consultants under this Contract, the Client shall make to the Consultants such payments and in such manner as is provided by Clause GC 6 of this Contract.

## **5.6 Counterpart Personnel**

- (a) If so provided in Appendix F hereto, the Client shall make available to the Consultants, as and when provided in such Appendix F, and free of charge, such counterpart personnel to be selected by the Client, with the Consultants' advice, as shall be specified in such **Appendix F**. Counterpart personnel shall work under the exclusive direction of the Consultants. If any member of the counterpart personnel fails to perform adequately any work assigned to him by the Consultants which is consistent with the position occupied by such member, the Consultants may request the replacement of such member, and the Client shall not unreasonably refuse to act upon such request.
- (b) If counterpart personnel are not provided by the Client to the Consultants as and when specified in Appendix F, the Client and the Consultants shall agree on (i) how the affected part of the Services shall be carried out, and (ii) the additional payments, if any, to be made by the Client to the Consultants as a result thereof pursuant to Clause GC 6.1(c) hereof.

## **6. Payments to the Consultants**

### **6.1 Cost Estimates; Ceiling Amount**

- (a) An estimate of the cost of the Services payable is set forth in Appendix G.
- (b) Except as may be otherwise agreed under Clause GC 2.6 and subject to Clause GC 6.1(c), payments under this Contract shall not exceed the ceilings specified in the SC. The Consultants shall notify the Client as soon as cumulative charges incurred for the Services have reached 80% of these ceilings. Notwithstanding Clause GC 6.1(b) hereof, if pursuant to clauses GC 5.3, 5.4 or 5.6 hereof, the Parties shall agree that additional payments shall be made to the Consultants in order to cover any necessary additional expenditures not envisaged in the cost estimates referred to in Clause GC 6.1(a) above, the ceiling or ceilings, as the case maybe, set forth in Clause GC 6.1(b) above shall be increased by the amount or amounts, as the case may be, of any such additional payments.

### **6.2 Remuneration and Reimbursable Expenditures**

- (a) Subject to the ceilings specified in Clause GC 6.1(b) hereof, the Client shall pay to the Consultants (i) remuneration as set forth in Clause GC 6.2(b), and (ii) reimbursable expenditures as set forth in Clause GC 6.2(c). If specified in the SC, said remuneration shall be subject to price adjustment as specified in the SC.

- (b) Remuneration for the Personnel shall be determined on the basis of time actually spent by such Personnel in the performance of the Services after the date determined in accordance with Clause GC2.3 and Clause SC2.3 (or such other date as the Parties shall agree in writing) (including time for necessary travel via the most direct route) at the rates referred to, and subject to such additional provisions as are set forth, in the SC.
- (c) Reimbursable expenditures actually and reasonably incurred by the Consultants in the performance of the Services, as specified in SC.
- (d) Notwithstanding anything to the contrary stated in the GCC and SCC, it shall be mandatory to deploy the key personnel and sub-professional as per the Man-Months Input specified in the Terms of Reference.

Inadequate deployment of key personnel and sub-professional shall lead to deduction in the monthly payment as per following table. The key personnel and sub-professional shall be considered to be inadequately deployed if he/she is not present for atleast 90% of the time stipulated in the month, as per the Man Months Input in the Terms of Reference and the Deployment Schedule proposed by the firm.

<b>Sr. No.</b>	<b>Personnel</b>	<b>% reduction in monthly payment</b>
<b>Normal Highway Project</b>		
1	Team Leader cum Senior Highway Engineer	20%
2	Resident Engineer cum Highway Engineer	25%
3	Bridge/Structural Engineer	20%
4	Other Key Personnel	20%
5	Sub- Professional Staff	15%
<b>Standalone Bridge Project</b>		
1	Team Leader cum Senior Bridge Engineer	20%
2	Resident cum Pavement Specialist	25%
3	Bridge/Structural Engineer	20%
4	Other Key Personnel	20%
5	Sub- Professional Staff	15%
<b>Standalone Tunnel Project</b>		
1	Team Leader cum Senior Tunnel Expert	20%
2	Resident Engineer cum Excavation Specialist	
3	Tunnel Design Engineer	20%
4	Other Key Personnel	20%
5	Sub- Professional Staff	15%

For avoidance of doubt, in case the Team Leader cum Senior Highway Engineer has not been made available for 90% of the stipulated time in the month, then only

80% of the monthly payment shall be released. In the case of “Other Key Personnel (Sr. No. 4)” and “Sub – Professional Staff (Sr. No. 5)”, the average availability across the group shall be considered for calculation.

Consultant have to provide a certificate that all key personnel as envisaged in the Contract Agreement has been actually deployed in the project. They have to submit the proof of Aadhaar based biometric attendance/ geo – tagged selfie – based attendance system at the time of submission of bills to the Barwa Adda Expressway Limited (BAEL).

### **6.3 Currency of Payment**

All payments shall be made in Indian Rupees and shall be subjected to applicable Indian laws withholding taxes if any.

### **6.4 Mode of Billing and Payment**

Billing and payments in respect of the Services shall be made as follows:

- (a) Deleted
- (b) As soon as practicable and not later than fifteen (15days)after the end of each calendar month during the period of the Services, the Consultants shall submit to the Client, in duplicate, itemized statements, accompanied by copies of receipted invoices, vouchers and other appropriate supporting materials, of the amounts payable pursuant to Clauses GC6.3 and 6.4 for such month. Each monthly statement shall distinguish that portion of the total eligible costs which pertains to remuneration from that portion which pertains to reimbursable expenditures.
- (c) 75% of bill raised by the Consultant shall be paid within 7 days and remaining bill may be paid after due scrutiny. The Client shall cause the payment of the Consultants periodically as given in schedule of payment above within thirty (30) days after the receipt by the Client of bills with supporting documents. Only such portion of a monthly statement that is not satisfactorily supported may be withheld from payment. Should any discrepancy be found to exist between actual payment and costs authorized to be incurred by the Consultants, the Client may add or subtract the difference from any subsequent payments. No interest shall be payable as from the above due date on any amount due by, but not paid on such due date.
- (d) The final payment under this Clause shall be made only after the final report and a final statement, identified as such, shall have been submitted by the Consultants and approved as satisfactory by the Client. The Services shall be deemed completed and finally accepted by the Client and the final report and final statement shall be deemed approved by the Client as satisfactory ninety (90) calendar days after receipt of the final report and final statement by the Client unless the Client, within such ninety (90)-day period, gives written notice to the Consultants specifying in detail deficiencies in the Services, the final report or final statement. The Consultants shall there upon promptly make any necessary corrections, and upon completion of such corrections, the foregoing process shall be

repeated. Any amount which the Client has paid or caused to be paid in accordance with this Clause in excess of the amounts actually payable in accordance with the provisions of this Contract shall be reimbursed by the Consultants to the Client within thirty, (30) days after receipt by the Consultants of notice thereof. Any such claim by the Client for reimbursement must be made within twelve (12) calendar months after receipt by the Client of a final report and a final statement approved by the Client in accordance with the above.

- (e) All payments under this Contract shall be made to the account of the Consultants specified in the SC.
- (f) Project Management Consultant will make payment of salary to all key personnel in their respective bank accounts through electronic mode only. No cash transaction w.r.t. salary will be made. Proof of salary transfer through electronic mode shall be submitted by the Project Management Consultant with each Bill.

## **7. Fairness and Good Faith**

### **7.1 Good Faith**

The Parties undertake to act in good faith with respect to each other's rights under this Contract and to adopt all reasonable measures to ensure the realization of the objectives of this Contract.

### **7.2 Operation of the Contract**

The Parties recognize that it is impractical in this Contract to provide for every contingency which may arise during the life of the Contract, and the Parties hereby agree that it is their intention that this Contract shall operate fairly as between them, and without detriment to the interest of either of them, and that, if during the term of this Contract either Party believes that this Contract is operating unfairly, the Parties will use their best efforts to agree on such action as may be necessary to remove the cause or causes of such unfairness, but no failure to agree on any action pursuant to this Clause shall give rise to a dispute subject to arbitration in accordance with Clause GC 8 hereof.

## **8. Settlement of Disputes**

### **8.1 Amicable Settlement**

The Parties shall use their best efforts to settle amicably all disputes arising out of or in connection with this Contractor the interpretation thereof.

### **8.2 Dispute Resolution**

- 8.2.1 Any dispute, difference or controversy of whatever nature howsoever arising under or out of or in relation to this Agreement (including its interpretation) between the Parties, and so notified in writing by either Party to the other Party (the “**Dispute**”) shall, in the first instance, be attempted to be resolved amicably in accordance with the conciliation procedure set forth in Clause 8.3.

8.2.2 The Parties agree to use their best efforts for resolving all Disputes arising under or in respect of this Agreement promptly, equitably and in good faith, and further agree to provide each other with reasonable access during normal business hours to all non – privileged records, information and data pertaining to any dispute.

### **8.3 Conciliation**

Deleted

### **8.4 Arbitration**

**8.4.1.** Any Dispute which is not resolved amicably by conciliation, as provided in Clause 8.3, shall be finally decided by reference to arbitration by an Arbitral Tribunal appointed in accordance with Clause 8.4.2. Such arbitration shall be held in accordance with the Rules of Arbitration of the International Centre for Alternative Dispute Resolution, New Delhi (the “Rules”), or such other rules as may be mutually agreed by the Parties, and shall be subject to the provisions of the Arbitration and Conciliation Act, 1996 as amended. The venue of such arbitration shall be New Delhi and the language of arbitration proceedings shall be English.

**8.4.2** Each dispute submitted by a Party to arbitration shall be heard by a sole arbitrator to be appointed as per the procedure below

- (a) Parties may agree to appoint a sole arbitrator or, failing agreement on the identity of such sole arbitrator within thirty(30) days after receipt by the other Party of the proposal of a name for such an appointment by the Party who initiated the proceedings, either Party may apply to the President, Indian Roads Congress, New Delhi for a list of not fewer than five nominees and, on receipt of such list, the Parties shall alternately strike names therefrom, and the last remaining nominee on the list shall be sole arbitrator for the matter in dispute. If the last remaining nominee has not been determined in this manner within sixty (60) days of the date of the list, the president, Indian Roads Congress, New Delhi, shall appoint, upon the request of either Party and from such list or otherwise, a sole arbitrator for the matter in dispute.

#### **8.4.3 Substitute Arbitrator**

If for any reason an arbitrator is unable to perform his function, a substitute shall be appointed in the same manner as the original arbitrator.

#### **8.4.4 Qualifications of Arbitrator**

The sole arbitrator selected pursuant to Clause 8.2.1 hereof shall be expert with extensive experience in relation to the matter in dispute.

8.4.5 The Arbitrators shall make a reasoned award (the “Award”). Any Award made in any arbitration held pursuant to this Clause 8 shall be final and binding on the Parties as from the date it is made, and the Consultant and the Employer agree and undertake to carry out such Award without delay.

- 8.4.6 The Consultant and the Employer agree that an Award may be enforced against the Consultant and/or the Employer, as the case may be, and their respective assets wherever situated.
- 8.4.7 This Agreement and the rights and obligations of the Parties shall remain in full force and effect, pending the Award in any arbitration proceedings hereunder

#### 8.4.8 Miscellaneous

In any arbitration proceeding hereunder:

- (a) Proceedings shall, unless otherwise agreed by the parties be held in Delhi.
- (b) The English language shall be the official language for all purposes;
- (c) The decision of sole arbitrator shall be final and binding and shall be enforceable in any court of competent jurisdiction, and the Parties hereby waive any objections to or claims of immunity in respect of such enforcement; and
- (d) The schedule of Expenses and Fee payable to the Arbitrator shall be as under

Sr. No.	Particulars of Fees and Expenses	Maximum amount payable per case
1	Fee	(i) Rs. 25,000/- per day; (ii) 25% extra on fee at (i) above in case of fast-track procedure as per Section -29 (B) of A&C Act; Or 10% extra on fee at (i) above if award is published within 6 months from date of entering the reference by AT; Alternatively, the Arbitrator may opt for a lump – sum fee of Rs. 5.00 Lakh per case including counter –claims.
2	Reading charges- one Time	Rs 25,000/- per case including counter claims.
3	One –time charges for Secretarial Assistance and Incidental Charges (telephone, fax, postage etc.)	Rs. 25,000/- per case
4	One time charges for publishing/declaration of the Award	Rs. 40,000/-
5	Other expenses (As per actual against bills subject to ceiling given below	
(i)	Travelling expenses	Economy class (by air), First class AC (by train) and AC Car (by road)



Sr. No.	Particulars of Fees and Expenses	Maximum amount payable per case
(ii)	Lodging and Boarding	Rs. 15,000/-per day (in metro cities); or Rs. 8000 per day (in other cities); or Rs. 5,000/- per day, if any Arbitrator makes their own arrangements.
6.	Local travel	Rs. 2,000 /- per day
7	Extra charges for days other than meeting days (maximum for 2 X ½ days)	Rs. 5000 /- per ½ day for outstation Arbitrator
Note	1. Lodging boarding and travelling expenses shall be allowed only for the arbitrator who is are residing 100 kms. away from the venue of meeting,	
	2. Delhi, Mumbai, Chennai, Kolkata, Bengaluru and Hyderabad shall be considered as Metro cities.	

In exceptional cases, such as cases involving major legal implications/wider ramifications/higher financial stakes etc. a special fee structure could be fixed in consultation with the Contractor/Supervision Consultants and with the specific approval of the Employer before appointment of the Arbitrator

#### 9. Fake CV

If any information is found incorrect/fake/inflated in the CV, at any stage, debarment of the key personnel from future Barwa Adda Expressway Limited (BAEL) projects upto 2 years may be taken by Barwa Adda Expressway Limited (BAEL). Further, in case, the information contained in the CV for the duration in which the key personnel:

(A) was employed by the firm, proposing his candidature is found incorrect/fake/inflated at any stage, action including termination of the Consultancy Agreement and debarment of the firm upto 02 years from future Barwa Adda Expressway Limited (BAEL) projects shall be taken by Barwa Adda Expressway Limited (BAEL).

(B) was employed by the firm, proposing his candidature is found incorrect/fake/inflated at any stage, the consultancy firms shall have to refund the salary and perks drawn in respect of the person apart from other consequences.

(C) was not employed by the firm, proposing his candidature is found incorrect/fake/inflated at any stage, the consultancy firms will have to refund the twice of salary and perks drawn in respect of the person.

10. In order to ensure construction of roads as per standard and specifications laid down in contract/concession agreement and to avoid project delays, it has been decided to debar/penalize/declare as Non-Performer the Employer 's Engineer (AE)/Independent Engineer (IE)/Construction Supervision Consultant (CSC)/ Project Management Consultant (PMC) for their lapses/deficiencies in services in National Highways and centrally sponsored road projects. It is clarified that such actions of the Employer would be without prejudice to the remedies available to Employer under the contract agreement/governing laws.

- A. The following penal actions shall be taken against the Construction Supervision Consultant/Project management Consultant in case of lapses on their part/deficiencies in services provided-

Sl. No.	Type of Deficiency	Action to be taken against Consultant (IE /AE /CSC /PMC) engaged during construction & maintenance	
		Key Personnel	Firm
1(a)	Failure to detect design/quality deficiency in Non-key Components*	For first three instances, key personnel may be kept on "watch list". Thereafter, the concerned Key Personnel & Team leader to be removed from the project and debarred up to 6 months	i. For first three instances, to be kept on watch list. ii. Thereafter, a monetary penalty of 1% of the consultancy fee (the aggregate of such penalties in a contract would not exceed the performance Guarantee amount) and/or declaring the consultant as NonPerformer up to 6 months or till rectification of deficiencies# and taking adequate measures not to repeat such instances in future, whichever is earlier.
(b)	Failure to issue follow-up notices to contractor/concessionaire for delays in closure of NCRs, delays in furnishing detail of time & cost claims/COS/ revised work programmes/work methodologies, etc.		
(c)	Delays or submission of improper MPRS, improper review of methodologies, temporary works, QA plan/manual, O&M plan/Manual etc.		
2(a)	Failure to detect design/quality deficiency in Key Component** not having substantial cost (below 1% of civil work (cost) and /or time implication (below 5% or project completion period)	The concerned key personnel & Team leader to be removed from the project and debarred up to 1 year	Declaring the Consultant as Non-Performer up to 1 year or till rectification of deficiencies# and taking adequate measures not to repeat such instances in future whichever is earlier
(b)	Failure to detect deficiency in quantity executed visà-vis design not having substantial financial implication (below 1% of civil work cost)		
(c)	Failure to conduct/witness tests as prescribed in the consultancy contract agreement		
(d)	Delay in processing EOT/COS proposals, inaccurate assessment of COS proposals, not issuing NCRs delays/ improper review of designs / drawings/ work programme or failure to submit Completion / Provisional Completion Certification as prescribed in contract		

Sl. No.	Type of Deficiency	Action to be taken against Consultant (IE /AE /CSC /PMC) engaged during construction & maintenance	
		Key Personnel	Firm
3			
(a)	Failure to detect deficiency in quantity executed vis-à-vis design having substantial financial implication (1% of civil work cost or more)	The concerned key personnel & Team leader to be removed from the project and debarred up to 2 year	In addition to rectification of deficiencies and taking adequate measure not to repeat such instances in future, the consultant to be debarred up to 2 years
(b)	Failure to detect design/quality deficiency in key component having substantial cost (1% of civil work cost or more) and / or time implication (5% of the project completion period of more)		
(c)	Failure to detect deficiency/not reviewing design (including temporary works) and construction (including methodology) of structural components of flyover /bridges /underpasses /overpasses/ ROB/RUB etc.		
(d)	Failure to propose action (like cure period notice, levy of damages, etc.) on contractor/concessionaire as per contract agreement for their default/poor progress having material adverse effect on the project implementation in terms of cost (1% of civil work cost or more) and/ time (5% of project completion period of more).		
(e)	Improper/wrong interpretation of provision in contract agreement; or wrong certification of payment/COS value/cost & time claims; or poor performance of services leading to cost (1% of civil work cost) and/or time (5% of project completion period) claims against MoRTH or its executing agencies awarded by DRB /CCIE / Arbitration/Court.		

**Note \*\* Key Components are specified as under:**

- i. Foundation, sub-structure and super-structure of flyovers, road over bridges, road under bridges, vehicular under passes, vehicular over passes, major bridges, minor bridges, etc.
- ii. Tunnels
- iii. Expansion joints and bearings
- iv. RE walls/ retaining walls
- v. The crust layers of flexible pavement
- vi. The crust layers of rigid pavement
- vii. Embankment and slope protection Issues affecting road safety Any other work endangering /impacting/ stability/ reliability/ durability/ performance of pavement/structures

\*The items not covered in above list shall be in the category of Non-key Components.

# Excluding the delay solely attributable to the contractor beyond stipulated time.

- B. Before deciding a CSC/PMC as Non-Performer or debarring/penalizing it, the concerned Employer shall issue a notice to the CSC/PMC by giving 15 days' time to furnish its written reply and allow personal hearing if so desired by the CSC/PMC before the competent authority or any person designated for the purpose. In case of projects where public safety is endangered by the behaviour /conduct/action of the consultant the Employer may temporarily suspend the consultant from participating in ongoing/ future bidding upto 1 month period during which the regular process of debarment shall be concluded.

BAEL and ITNL will designate competent authority for deciding penal action and the Reviewing Authority.

- C. Upon declaration of non-performer, the CSC/PMC will not be able to participate in any bid for National Highways projects with MoRTH or any other executing agencies till such time the debarment persists or the CSC/PMC is removed from the list of non-performers. The CSC/PMC shall include its JV partners, promoters etc. whose credentials were considered while qualifying them for the project. Non-performer/debarment status of a bidder on the bid due date will be the criteria for eligibility of a bidder to participate in the said bid.

## II. SPECIAL CONDITIONS OF CONTRACT

### GC Clause

#### A. **Amendments of, and Supplements to, Clauses in the General Conditions of Contract**

1.1(a) The words "in the Government's country" are amended to read "in INDIA"

1.4 The language is: English

1.6.1 The addresses are:

Client: \_\_\_\_\_ Address of Employer  
Attention: \_\_\_\_\_  
Telex : \_\_\_\_\_  
Facsimile : \_\_\_\_\_  
Consultant: \_\_\_\_\_ Address of Consultant  
Attention: \_\_\_\_\_  
Cable address : \_\_\_\_\_  
Telex : \_\_\_\_\_  
Facsimile : \_\_\_\_\_  
*[Note' : Fill in the Blanks]*

1.6.2 Notice will be deemed to be effective as follows:

- (a) in the case of personal delivery or registered mail, on delivery;
- (b) in the case of telexes, 24 hours following confirmed transmission;
- (c) in the case of telegrams, 24 hours following confirmed transmission; and
- (d) in the case of facsimiles, 24 hours following confirmed transmission.

1.8 The Member in Charge is: Member (P) Sh. \_\_\_\_\_

*(Note: If the Consultants consist of a joint venture of more than one entity, the name of the entity whose address is specified in SC1.6.1 should be inserted here. If the Consultants consist of one entity, this Clause 1.8 should be deleted from the SC)*

1.9 The Authorised Representative are:

For the Client: \_\_\_\_\_

For the Consultants: \_\_\_\_\_

1.10 The Consultants, Sub-consultants and the Personnel shall pay the taxes, duties, fees, levies and other impositions levied under the existing, amended or enacted laws during life of this contract and the client shall perform such duties in regard to the deduction of such tax as may be lawfully imposed.

2.1 The effectiveness conditions are the following:

- i) Approval of the Contract by the client
- 2.2 The time period shall be four months or such other time period as the parties may agree in writing.
- 2.3 The time period shall be one month or such other time period as the Parties may agree in writing.
- 2.4 The time period shall be 18 months

### **3.4 Limitation of the Consultants' Liability towards the Client**

- (a) Except in case of gross negligence or wilful misconduct on the part of the Consultants or on the part of any person or firm acting on behalf of the Consultants in carrying out the Services, the Consultants, with respect to damage caused by the Consultants to the Client's property, shall not be liable to the Client:
  - (i) for any indirect or consequential loss or damage; and
  - (ii) Consultant will maintain at its expenses; Professional Liability Insurance including coverage for errors and omissions caused by Consultant's negligence in the performance of its duties under this agreement,(A)For the amount not exceeding total payments for Professional Fees and Reimbursable Expenditures made or expected to be made to the Consultants hereunder OR (B) the proceeds, the Consultants may be entitled to receive from any insurance maintained by the Consultants to cover such a liability, whichever of (A) or (B) is higher.
  - (iii) The policy should be issued only from an Insurance Company operating in India.
  - (iv) The policy must clearly indicate the limit of indemnity in terms of "Any One Accident"(AOA) and "Aggregate limit on the policy period"(AOP) and in no case should be for an amount less than stated in the contract.
  - (v) If the Consultant enters into an agreement with Employer in a joint venture or 'in association', the policy must be procured and provided to Employer by the joint venture/in association entity and not by the individual partners of the joint venture/association.
  - (vi) The contract may include a provision whereby the Consultant does not cancel the policy midterm without the consent of the Employer. The insurance company may provide an undertaking in this regard.
    - (b) This limitation of liability shall not affect the Consultants' liability, if any, for damage to Third Parties caused by the Consultants or any person or firm acting on behalf of the Consultants in carrying out the Services.
    - (c) Professional Liability Insurance may be accepted for initially one year which shall be extended annually for two and half years (30 months from the Effective Date). PLI shall be uniformly taken for a period of two and half years.

### 3.5 The risks and the coverage shall be as follows

- (a) Third Party motor vehicle liability insurance as required under Motor Vehicles Act,1988 in respect of motor vehicles operated in India by the Consultants or their Personnel or any Sub-consultants or their Personnel for the period of consultancy.
- (b) Third Party liability insurance with a minimum coverage, of Rs. 1.0 million for the period of consultancy.
- (c) Professional liability insurance as per 3.4 (a) (ii) of SC of the consultancy, with a minimum coverage equal to estimated remuneration and reimbursable.
- (d) Employer's liability and workers' compensation insurance in respect of the Personnel of the Consultants and of any Sub-consultant, in accordance with the relevant provisions of the Applicable Law, as well as, with respect to such Personnel, any such life, health, accident, travel or other insurance as may be appropriate; and
- (e) Insurance against loss of or damage to(i) equipment purchased in whole or in part with funds provided under this Contract, (ii) the Consultants' property used in the performance of the Services, and(iii)any documents prepared by the Consultants in the performance of the Services.

3.7(c) The other actions are

- "(i) taking any action under a civil works contract designating the Consultants as "Construction Supervision Engineer", for which action, pursuant to such civil works contract, the written approval of the Client as "Employer" is required".

3.9 The Consultants shall not use these documents for purposes unrelated to this Contract without the prior written approval of the Client.

4.6 "The person designated as Team Leader cum Senior Highway Engineer in Appendix C shall serve in that capacity, as specified in Clause GC 4.6."

6.1(b) The amount payable Indian Rupee is : \_\_\_\_\_

6.2(a) "Payments for remuneration and reimbursable items made in accordance with Clause GC 6:2(a) :

- (i) Consultants shall be paid billing rates for services rendered by the personnel of all categories namely (i) key Personnel; (ii) sub-Professional personnel and (iii) Support staff on man-month basis . Billing rates of remaining items of the financial proposal, namely (i) transportation , (ii) Duty travel to site (iii) Office Rent, (iv) office supplies communication etc. (v) reports & document printing and (vi) survey equipment etc. shall be worked out month wise as per actual expenditure All payments shall be made in Indian Rupees and shall be subjected to applicable Indian laws withholding taxes if any.

(ii)

Notwithstanding any other provisions in the agreement in this regard, this provision will prevail and override any other provision to the contrary in this agreement.

- 6.2(b) (i) (1) Payment of Project Management Consultant shall be released on approval of the monthly reports. Report shall be approved by the Employer only if it includes all the sections prescribed in the format and submitted as per specified timelines.
- (2) Payment shall be released as per rates quoted in Appendix C3- Breakup of Local currency costs
- (3) For equipment based road inspection to be conducted in O&M phase, payment shall be released as per actual use of equipment on road and rates quoted in Appendix C3- Breakup of Local currency costs.
- (4) If any of the report is found to be misleading or containing incorrect information as determined by the Employer, 10% of payment linked to that report shall be deducted as penalty
- (5) It is understood(i)that the remuneration rates shall cover(A) such salaries and allowances as the Consultants shall have agreed to pay to the Personnel as well as factors for social charges and overhead, and (B)the cost of back stopping by home office staff not included in the Personnel listed in Appendix C, and(C)the Consultants' fee;(ii)that bonuses or other means of profit-sharing shall not be allowed as an element of overhead, and (iii) that any rates specified for persons not yet appointed shall be provisional and shall be subject to revision, with the written approval of the Client, once the applicable salaries and allowances are known.
- (6) Remuneration for periods of less than one month shall be calculated on an hourly basis for actual time spent in the Consultants' home office and directly attributable to the Services(one hour being equivalent to 1/240th of a month) and on a calendar-day basis for time spent away from home office(one day being equivalent to 1/30th of a month).

6.2(b)(ii) The rates for foreign and local Personnel are set forth in Appendix G

6.4(a) Deleted

6.4 (c) Deleted

6.4(e) The accounts are:

[Note: Insert account number, type of account and name and address of the Bank]

8.2 Disputes shall be settled by arbitration in accordance with the following provisions:



#### **IV. APPENDICES**

##### **Appendix A: Description of the Services**

*[Give detailed descriptions of the Services to be provided; dates for completion of various tasks, place of performance for different tasks; specific tasks to be approved by Client, etc.]*

**Details as per TOR**

## **Appendix B: Reporting Requirements**

*[List format, frequency, contents of reports and number of copies; persons to receive them; dates of submission etc. If no reports are to be submitted, state here "Not applicable".]*

**Please refer TOR**

### **Appendix C: Key Personnel and Sub-consultants**

*[List under: C-1 Titles [and names, if already available], detailed job descriptions and minimum qualifications. Experience of Personnel to be assigned to work in India, and staff-months for each.*

*C-2 Same information as C-1 for Key local Personnel.*

*C-3 Same as C-1 for Key foreign Personnel to be assigned to work outside India.*

*C-4 List of approved Sub-consultants [if already available]; same information with respect to their Personnel as in C-1 through C-4)*

**Please refer TOR**

## **Appendix D: Medical Certificate**

*[Show here an acceptable form of medical certificate for foreign Personnel to be stationed in India. If there is no need for a medical certificate, state here: "Not applicable. "]*

**The form of Medical Certificate as required under the rules of Govt. of India**

### **Appendix E: Hours of Work for Key Personnel**

The Consultants Key personnel and all other Professional / Sub Professional / Support Staff/Sub-Consultancy personnel shall work 6 days (Mondays through Saturday) every week and observe the Gazetted Holidays of Government of India as Holidays. The Consultant shall work as per the work program of the EPC Contractor. In this context in case the work plan of the Consultant needs suitable modifications, the same shall be carried out and submitted to the client for consideration. The Consultants hours of work normally shall match with that of Contractor's activities on the site. No extra remuneration shall be claimed or paid for extra hours of work required in the interest of Project completion.

In respect of foreign personnel, one day per trip as travel time from and to the country of the Government shall be allowed.

## **Appendix F: Duties of the Client**

[List here under:

F-1 Services, facilities and property to be made available to the Consultants by the Client.

F-2 Counterpart personnel to be made available to the Consultants by the Client.]

**Please refer TOR**

## **Appendix G: Cost Estimates**

*List hereunder cost estimate in INR:*

1. *Monthly rates for local Personnel (Key Personnel and other Personnel)*
2. *Reimbursable/Rental/Fixed expenditures as follows:*
  - a. *Cost of local transportation.*
  - b. *Cost of other local services, rentals, utilities, etc.*

**Appendix H: FORM OF PERFORMANCE SECURITY**

**(PERFORMANCE BANK GUARANTEE)**

(Clause-13 of TOR)

To

Address of Employer:

WHEREAS \_\_\_\_\_ [Name and address of Consultants]<sup>1</sup> (hereinafter called “the consultants”) has undertaken, in pursuance of Contract No. \_\_\_\_\_ dated \_\_\_\_\_ to provides the services on terms and conditions set forth in this Contract \_\_\_\_\_ [Name of contract and brief description of works] (hereinafter called the “the Contract”).

AND WHEREAS it has been stipulated by you in the said Contract that the Consultants shall furnish you with a Bank Guarantee by a recognized bank for the sum specified there in as security for compliance with his obligations in accordance with the Contract;

AND WHEREAS we have agreed to give the Consultants such a Bank Guarantee;

NOW THEREOF we hereby affirm that we are the Guarantor and responsible to you, on behalf of the Consultants up to a total of [amount of Guarantee]<sup>2</sup> \_\_\_\_\_ [in words], such sum being payable in the types and proportions of currencies in which the Contract Price is payable, and we undertake to pay you, upon your first written demand and without cavil or argument, any sum or sums within the limits of [amount of Guarantee] as aforesaid without your needing to prove or to show grounds or reasons for your demand for the sum specified therein.

We hereby waive the necessity of your demanding the said debt from the Consultants before presenting us with the demand.

We further agree that no change or addition to or other modification of the terms of the Contract or of the services to be performed there under or of any of the Contract documents which may be made between you and the Consultants shall in any way release us from any liability under this guarantee, and we hereby waive notice of any such change, addition or modification.

The liability of the Bank under this Guarantee shall not be affected by any change in the constitution of the consultants or of the Bank.

Notwithstanding anything contained herein before, our liability under this guarantee is restricted to Rs. \_\_\_\_\_ (Rs. \_\_\_\_\_) and the guarantee shall remain valid till \_\_\_\_\_. Unless a claim or a demand in writing is made up on us on or before \_\_\_\_\_ all our liability under this guarantee shall cease.

This guarantee shall be valid for a period of 21 months i.e. upto 3 months beyond the expiry of contract of 18 months.

.....[Name of Consultants] on whose behalf this guarantee has been given Bank hereby confirms that it is on the SFMS (Structural Finance Messaging System) platform and shall invariably send an



advice of this Bank Guarantee to the designated bank of BAEL after obtaining details thereof from BAEL.

Details of designated bank of BAEL for the purpose of SFMS (Structural Finance Messaging System) is as under:

Name of Beneficiary : Barwa Adda Expressway Limited (BAEL)  
Name of Bank: BANK OF BARODA  
Account No. 29100200000238  
IFSC Code: BARB0CFSBAL

Signature and Seal of the Guarantor \_\_\_\_\_ In presence of

Name and Designation \_\_\_\_\_

1. \_\_\_\_\_

(Name, Signature & Occupation)

Name of the Bank \_\_\_\_\_

Address 2. \_\_\_\_\_

(Name & Occupation)

Date \_\_\_\_\_

## Appendix I

### BID SECURITY (BANK GUARANTEE)

WHEREAS, \_\_\_\_\_ [*name of Bidder*] (hereinafter called "the Bidder") has submitted his Bid dated \_\_\_\_\_ [*date*] for the works "**Consultancy Services of the Project Management Consultant for carrying out supervision of the balance construction works of Six-laning of Barwa Adda Panagarh section of NH-2 from km 398.240 to km 521.120 including Panagarh bypass in the states of Jharkhand and West Bengal under NHDP Phase V on DBFOT basis (Project)**" (Hereinafter called "the Bid").

**Scope** \_\_\_\_\_

KNOW ALL PEOPLE by these presents that We \_\_\_\_\_ [*name of bank*] having our registered office at \_\_\_\_\_ (hereinafter called "the Bank") are bound unto BAEL (hereinafter called "the Employer") in the sum of \_\_\_\_\_ for which payment well and truly to be made to the said Employer the Bank binds itself, his successors and assigns by these presents.

SEALED with the Common Seal of the said Bank this \_\_\_\_\_ day of \_\_\_\_\_ 2021

THE CONDITIONS of this obligation are:

- (1) If after Bid opening the Bidder withdraws his Bid during the period of Bid validity specified in the Form of Bid; or
- (2) If the Bidder having been notified of the acceptance of his Bid by the Employer during the period of Bid validity:
  - (a) fails or refuses to execute the Form of Agreement in accordance with the Instructions to Bidders, if required; or
  - (b) fails to submit Performance Security

(c) does not accept the correction of the Bid Price pursuant to Clause 27 of ITB;

we undertake to pay to the Employer up to the above amount upon receipt of his first written demand, without the Employer having to substantiate his demand, provided that in his demand the Employer will note that the amount claimed by him is due to him owing to the occurrence of one or any of the three conditions, specifying the occurred condition or conditions.

This Guarantee will remain in force up to and including 120 days after the Bid validity period as stated in the Instructions to Bidders or as it may be extended by the Employer, notice of which extension(s) to the Bank is hereby waived. Any demand in respect of this guarantee should reach the Bank not later than the above date.

DATE \_\_\_\_\_ SIGNATURE OF THE BANK \_\_\_\_\_

WITNESS \_\_\_\_\_ SEAL \_\_\_\_\_

\_\_\_\_\_  
[signature, name, and address]

## **Appendix J**

### **Letter of invitation**

## **Appendix K**

### **Letter of Award**

## **Appendix L**

### **Minutes of pre-bid meeting**

## Appendix-M

Deleted

**DISCLAIMER**

The Applicant must read all the instructions in the RFP and submit the same accordingly.